

# Subminiature Power Relay ETS

- Slim size (width 5mm)
- High breakdown voltage 4kV (between coil and contacts)
- Surge voltage up to 6kV (between coil and contacts)
- Clearance/creepage distance: 8mm
- High sensitive: 170mW
- 1 Form A and 1 Form C configurations



## Options and ordering codes

<b>ETS</b>	-	<b>1A</b>		<b>N</b>	-	<b>S</b>	-	<b>L</b>	-	<b>12VDC</b>
Contact Form										Coil Voltage
SPNO		<b>1A</b>						<b>L</b>		RoHS Compliant
SPCO		<b>1C</b>								
Contact Material										Sealing
AgNi				<b>N</b>				<b>S</b>		Sealed
AgNi + Au Plate				<b>N1</b>						

## Contact Data

Contact arrangement	1A, 1C
Initial contact resistance Max.	100mΩ (at 1A 6VDC) Gold plated: 30mΩ (at 1A 6VDC)
Contact material	AgNi
Contact Rating (Res. load)	6A 250VAC / 30VDC
Max. switching voltage	400VAC / 125VDC
Max. switching current	6A
Max. switching power	1500VA / 180W
Mechanical Life	1x10 <sup>7</sup> OPS
Electrical Life	NO / NC: 1x10 <sup>4</sup> OPS (at 85°C)

## Characteristics

Initial Insulation Resistance	1000MΩ @ 500VDC	
Dielectric Strength	Between coil & contact	4000VAC 1min.
	Between open contacts	1000VAC 1min.
Operate time (at nomi. Volt)	Max. 8ms	
Release time (at nomi. Volt)	Max. 4ms	
Shock Resistance	Functional	50m/s <sup>2</sup>
	Destructive	1000m/s <sup>2</sup>
Vibration Resistance	10 to 55Hz 1mm DA	
Humidity	5 to 85% RH	
Ambient Temp	-40°C to +85°C	
Termination	PCB	
Unit Weight	5.4g	
Construction	Sealed IP67, Flux proof	

## Coil

Coil power	5 to 24VDC: 170mW 48VDC, 60VDC: 210mW
------------	--

## Coil Data

Coil Voltage VDC	Pick-up Voltage VDC	Drop-out Voltage VDC	Max allowable voltage (VDC 85°C)	Coil Resistance Ω ± 10%
5	3.75	0.25	7.5	147±10%
6	4.50	0.30	9.0	212±10%
9	6.75	0.45	13.5	476±10%
12	9.00	0.60	18	848±10%
18	13.5	0.90	27	1906±15%
24	18.0	1.20	36	3390±15%
48	36.0	2.40	72	10600±15%
60	45.0	3.00	90	16600±15%

Notes: 1) When require pick-up voltage=70% nominal voltage, special order allowed  
2) When install 1 Form C type of ETS, please do not make the relay side with 5mm width down

## Safety Approval Ratings

UL & CUR	6A 30VDC Resistive: 6A 277VAC Pilot duty: R300
----------	--

# Subminiature Power Relay ETS continued



## Outline dimensions (mm)

Wiring diagram and PC Board layout

1A

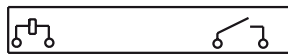
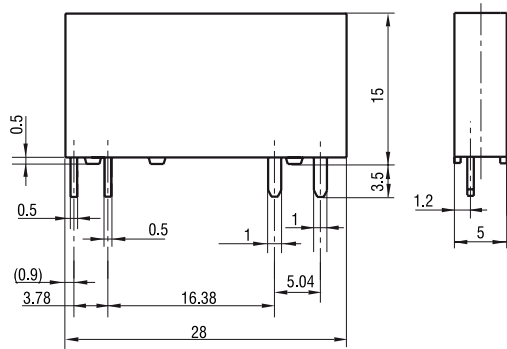

1C

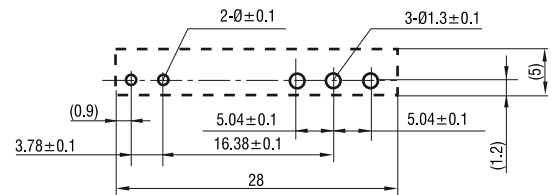
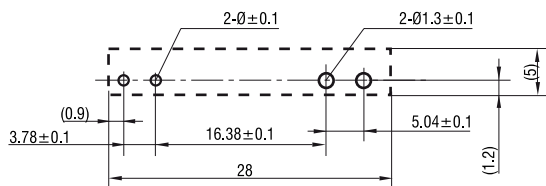
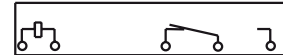
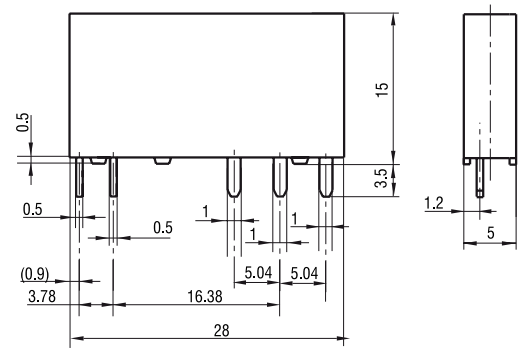

## Characteristic Curve

MAX. SWITCHING POWER

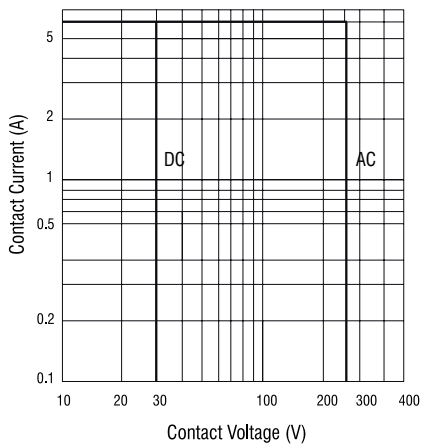

LIFE CURVE

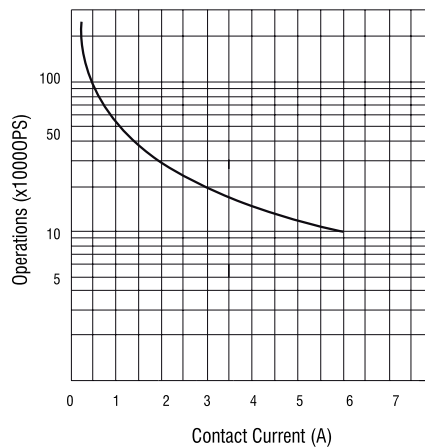

COIL TEMPERATURE RISE

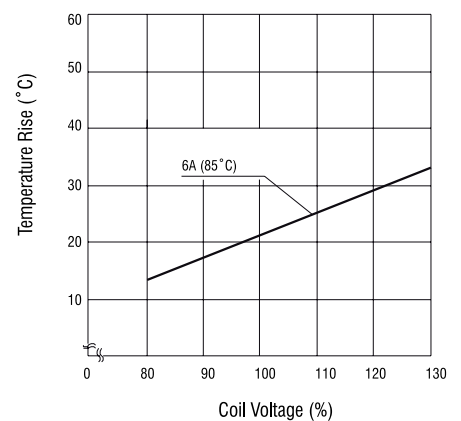

## Characteristics

Ambient temperature	-40 to 70 °C
Rated voltage	250VAC
Rated current	6A (Per pole)
Insulation voltage (min.)	5000VAC
Protection degree	IP20
Socket material	PA66+GF V0 (UL)
Contacts spring material	QSn6.5-0.1
Retainer	No
Modules (on request)	Self-contained
Terminal torque	0.6Nm
Wire strip length	7mm

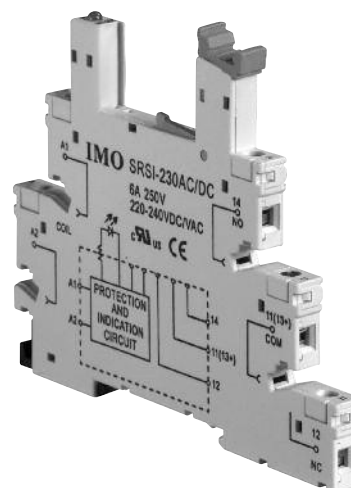

## Outline dimensions

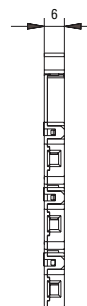
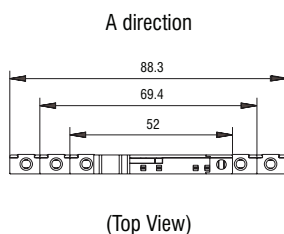
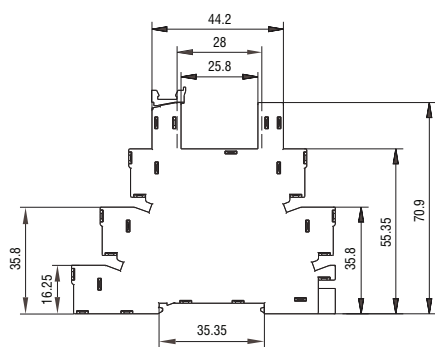

## Socket/relay compatibility

Socket P/N	Input voltage	Relay coil voltage
SRSI-24AC/DC	6 to 24VDC/VAC	6 to 24VDC
SRSI-60AC/DC	48 to 60VDC/VAC	48 to 60VDC
SRSI-110AC/DC	110 to 125VDC/VAC	60VDC
SRSI-230AC/DC	220 to 240VDC/VAC	60VDC

Note: Input voltage polarity not required

## SRSI- CC20 Busbar available in 20 way

