Pump Control Guide
PUMP Application Inverter

IMO Jaguar VXA

CAUTION

Thank you for purchasing our Jaguar VXA series of inverters.

- This product is designed to drive a three-phase induction motor. Read through this instruction manual and be familiar with the handling procedure for correct use.
- Improper handling might result in incorrect operation, a short life, or even a failure of this product as well as the motor.
- Deliver this manual to the end user of this product. Keep this manual in a safe place until this product is discarded.
- For how to use an optional device, refer to the instruction and installation manuals for that optional device.

Copyright © 2016 IMO Precision Controls Ltd

All rights reserved.

No part of this publication may be reproduced or copied without prior written permission from IMO Precision Controls Ltd.

All products and company names mentioned in this manual are trademarks or registered trademarks of their respective holders.

The information contained herein is subject to change without prior notice for improvement.

Thank you for purchasing the **Jaguar-VXA**, IMO's inverter for pump and compressor applications.
 This guide is structured as follows:

CHAPTER 0: Introduction to pressure control systems

9 types of pump control 5

CHAPTER 1: Single pump control

Electrical diagram 6
 Sleep Function 7
 Wake-up Function 7
 Common parameters for pump control 9
 Common parameters description 10

CHAPTER 2: Mono-regulated pump control with 1 regulated pump + 1,2,3 or 4 auxiliary pumps

Mono-regulated pump (mono-joker) control with 1 regulated pump + 1 auxiliary pump electrical diagram 12
 Mono-regulated pump (mono-joker) control with 1 regulated pump + 2 auxiliary pumps electrical diagram 13
 Mono-regulated pump (mono-joker) control with 1 regulated pump + 3 auxiliary pumps electrical diagram 14
 Mono-regulated pump (mono-joker) control with 1 regulated pump + 4 auxiliary pumps electrical diagram 15
 Connecting auxiliary pumps 17
 Disconnecting auxiliary pumps 18
 Common Parameters for pump control 19
 Specific parameters 20
 Specific parameters description 20

CHAPTER 3: Mono-regulated pump control with 1 regulated pump + 4 auxiliary pumps + 1 additional pump

Electrical diagram 22
 Common parameters for pump control 24
 Specific Parameters 25
 Specific parameters description 25

CHAPTER 4: Multi-regulated pump (multi-joker) control with 2/3 regulated pumps

Multi-regulated pump (Multi-joker) control with 2 regulated pumps electrical diagram 27
 Multi-regulated pump (Multi-joker) control with 3 regulated pumps electrical diagram 28
 Connecting a regulated pump to commercial power supply 30
 Disconnecting a regulated pump from commercial power supply 30
 Common parameters for pump control 32
 Specific parameters 33
 Specific parameters description 33
 Specific parameters description having optional card relay installed 34

CHAPTER 5: Multi-regulated pump (Multi-joker) control with 3 regulated pumps + 1 additional pump

Electrical diagram 35
 Common parameters for pump control 37
 Specific Parameters 38
 Specific parameters description 39

CHAPTER 6: Additional Functions

Dry Pump function 40
 Overpressure alarm 41
 User units set-up 42
 Start-up and switching motors sequence 42
 Contactor delay time 43
 Stopping mode selection when removing "RUN" signal (FWD or REV goes off) 43
 Multiple PID set points selection 43
 Dead band 44
 Dew condensation prevention function 44
 PID Integral component hold 44
 Enable / disable pumps by means of external selectors 46

CHAPTER 7: Function codes list. Digital and analog I/O functions

..... 47

CHAPTER 8: Names and functions of keypad components

..... 70

CHAPTER 9: Optional relay card OPC-G1-RY/OPC-G1-RY2

..... 71

CONTACT INFORMATION

..... 72

Chapter 0

Introduction to pressure control systems

The target of a pressure control system is to provide a variable flow with a constant pressure for the water system of an apartment building, machine refrigeration systems, mixing liquids in chemical industry, etc.

A very typical example is to provide the water supply for a residential building. In this case, the flow (water consumption) is greater in the morning than during the night (when it is almost zero). The pressure control system must be able to provide, at the same pressure, both types of consumption (daytime→higher flow, during the night→ almost no flow); in addition, the system has to adapt to the demand variations that occur normally in this kind of application, for example, when people turn on and off many taps at the same time.

The **Jaguar-VXA** inverter has been designed to fulfil all the requirements of the different pump control systems. Some of its more important functions are:

- Stop function due to low water flow (Sleep Function)
- Start-up function because of water demand (Wake-up Function)
- Operation limits (current, voltage and frequency) to protect the motor and the pump
- Control of multiple pumps on 1 regulated pump + auxiliary pumps topology (Mono-regulated pump Control)
- Control of multiple pumps on multi regulated pumps topology (Multi-regulated pump Control)
- Possibility to add an additional pump (AUX_L Function) to both topologies
- Many functions to avoid overpressure and water losses (Warnings, alarms, etc.)
- Possibility of precise adjustment of the levels for start-up and stop of the auxiliary pumps to fine tune the system behaviour
- Possibility of the precise adjustment of the levels to start-up and stop of the PID control, during the connection/disconnection of the auxiliary pumps, to fine tune the system behaviour
- Independent ramps for the start-up and the stop of the regulated pump, separate from the ramps for the connection/disconnection of auxiliary pumps
- Selection of the sequence for the pumps start-up and stop
- Sequenced switching rotation of the pumps (by timer or intelligent control)
- Possibility of sharing the working time between the pumps
- Information about the working time of each pump
- Pressure sensor disconnection detection
- Selecting different warnings (low-pressure, overpressure, etc.)
- Protective function to protect pump from the absence of water (Dry well function)
- "By-pass" sequence integrated
- Control of the delay time between connection and disconnection of the contactors
- Display units and sensor range adjustments
- Selectable 'Pump Stop' Strategy
- Multiple frequency command selection (by means of digital inputs)
- Dew condensation prevention Function
- Energy Saving Functions

Regulation by means of PID control:

A PID control is a regulation system involving the set value (SV - desired pressure) and a process value (PV - Feedback, measure of real pressure or flow from a transducer). From these two values the difference, or error, is calculated, subtracting one from the other. The PID control then adjusts its output demand (MV - pump's speed) in order to minimize the error:

-If the error is positive (desired pressure greater than real pressure) speed should increase

-If the error is negative (desired pressure lower than the real pressure) speed should decrease

-If the error is zero (desired pressure equal to real pressure) speed should stay at the same level

Parameters (gains) to adjust: Proportional, Integral and Derivative components (though Derivative component is not normally used in this application) help to select how quickly the system will respond to pressure and consumption changes. Normally, a quick (dynamic) response is desired, but pressure peaks and oscillations must be avoided.

QUICK GUIDE

PUMP CONTROL

Jaguar-VXA frequency inverter is able to control single or multiple pumps in mono-regulated or multi-regulated configuration. Several control schemes may be built as shown below:

The necessary digital outputs will vary depending on the control type has been chosen (OPC-G1-RY or OPC-G1-RY2 optional cards may be necessary).

	Necessary digital outputs	Do we need the optional relay card installed?	Explained in...
Single pump control	0	NO	CHAPTER 1
Single pump control consists of 1 pump exclusively controlled by the frequency inverter			

MONO-REGULATED PUMP CONTROL (FIXED) up to 10 pumps (Mono-joker) J401=1				Necessary digital outputs	Do we need the optional relay card installed?	Explained in ...
1 regulated Pump	+	1 auxiliary pump (On-Off control)		1	NO	CHAPTER 2
		2 auxiliary pumps (On-Off control)		2	NO	
		3 auxiliary pumps (On-Off control)		3	YES (OPC-G1-RY)	
		4 auxiliary pumps (On-Off control)		4	YES (OPC-G1-RY)	
		5 auxiliary pump (On-Off control)		5	YES (OPC-G1-RY2)	NOT EXPLAINED
		6 auxiliary pump (On-Off control)		6	YES (OPC-G1-RY2)	
		7 auxiliary pump (On-Off control)		7	YES (OPC-G1-RY2)	
		8 auxiliary pump (On-Off control)		8	YES (OPC-G1-RY2)	
		4 auxiliary pumps (On-Off control)		+	1 additional pump (On-Off control)	5

Mono-regulated pump control consists of 1 pump exclusively controlled by the frequency inverter and multiple auxiliary pumps working in On-Off control mode. Additional pump is added / removed depending on the regulated pump speed and if auxiliary pumps are all enabled or not.

MULTI-REGULATED PUMP CONTROL (FLOATING) up to 4 pumps (Multi-joker) J401=2				Necessary digital outputs	Do we need the optional relay card installed?	Explained in ...
2 regulated pumps				4	YES (OPC-G1-RY)	CHAPTER 4
3 regulated pumps				6	YES (OPC-G1-RY2)	
4 regulated pumps				8	YES (OPC-G1-RY2)	NOT EXPLAINED
3 regulated pumps	+	1 additional pump (On-Off control)		7	YES (OPC-G1-RY2)	CHAPTER 5

Pumps working on Multi-regulated mode are all inverter driven. Additional pump is added / removed depending on the regulated pump speed and if others are also enabled or not.

Chapter 1

Single pump control

Single pump control	Necessary digital outputs	Do we need the optional relay card installed?
	0	NO

When a regulated pump is being controlled, it's necessary to consider certain parameters in order to allow the inverter to control the pump's start-up and stop, controlling speed to maintain the desired pressure, etc.

The schematic to implement control by only 1 pump by means of **Jaguar-VXA** inverter, is as follows:

Please note the pressure transducer is connected to the inverter's analog input C1 (4-20 mA)

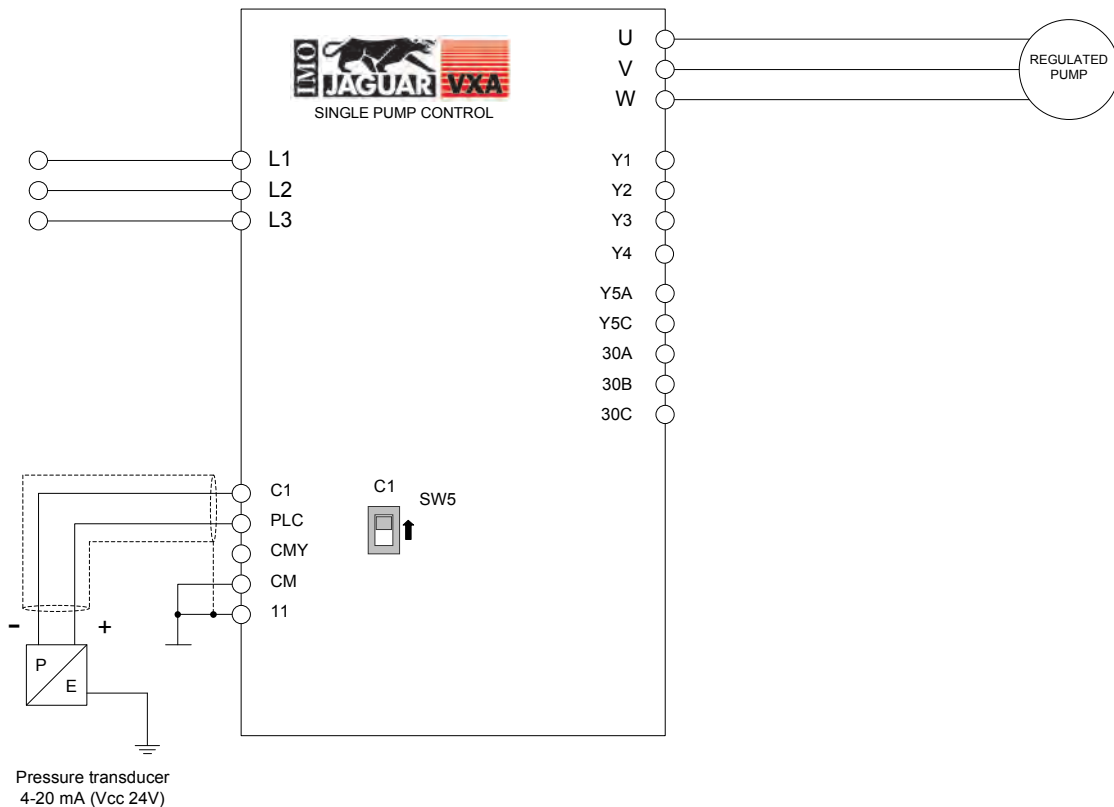

Figure 1.1: control schematic for 1 pump only

By means of the VXA keypad, a digital input or an analog set point, the desired pressure can be selected. Once this pressure is set, inverter will modify pump's speed between a minimum (J119 = F16 (Hz)) and a maximum (J118=F15=F03 (Hz)) frequencies, in order to stabilize the pressure.

To work in this way, the integrated PID Control 1 must be enabled (J101) and adjusted properly. Then, the inverter's response should be the required action to control the application.

PID's response can be modified by means of parameters J110 and J111 (Proportional gain and Integral time).

When the "RUN" signal is switched on (either FWD or REV), the inverter will increase the output frequency (always after the period time defined in J454 (s)). In order to control this rising output, some parameters are available: F23 (Hz) controls the starting frequency, F16 the frequency limiter (low) and the ramp from one to the other (F07) (s). PID Control 1 is enabled since RUN command is given. In the same way, when the "RUN" signal is switched off, the inverter decrease its output frequency to the level defined in F25 (Hz) (the deceleration time is set in F08 (s)), and stops the PID Control 1.

➤ **Sleep Function (related parameters: J150 (Hz), J151 (s))**

Sleep function can be useful to stop one pump when the speed is below a rate where there is no flow (pump doesn't impel).

Once the demand frequency level below this rate (the frequency when the pump begins to move the water but not enough to create a flow) is known, parameter J150 (Hz) should be set slightly higher than this frequency.

Through this function, is possible to avoid possible mechanical problems that could (over time) damage pump components or 'boil' the water with the wasted energy causing excess pressure and leaks. In addition, stopping the pump when it's not really needed means, obviously, Energy Saving.

So, Sleep Function will be applied if the inverter's demand output frequency is lower than the 'sleep' level stored in parameter J150 (Hz) and it stays at a lower level for a time longer than that specified in J151 (s).

In Figure 1.2 and 1.3 sleep function is shown. The deceleration time to get to the "Stop Frequency" is stored in F08 (s).

In order to have this function active, J149 must be different than 0. For additional details, refer to J149 parameter description.

Important: Sleep frequency (J150 (Hz)) must be lower than the wake-up frequency (J157 (Hz)) and must be higher than the minimum frequency (F16=J119).

➤ **Wake-up function (related parameters J157 (Hz), J158 (%), J159 (s))**

Wake-up function is useful to start-up a pump again that previously was stopped by the sleep function.

In order to wake up a pump two condition must be accomplished (type of condition depends on J149 setting):

MV ≥ J157 (Hz) (J149=1,11,21)		 SV – PV ≥ J158 (%) (J149=2,12,22)		Delay Time ≥ J159 (s) (J149=2,12,22)
Manipulated value (MV, PID's output) must be greater than the level stored in J157 (the current MV value is shown on VXA keypad according to recommended setting)	or...	The absolute value of the process error (the subtraction between the process value and the set point value) must be greater than the percentage in J158	and...	The percentage set in J158 is kept longer than the time specified in J159

(*) J158 is related with C65 and C66 function codes as follows: $(|SV - PV|) / (C65 - C66) \geq J158 (\%)$ (C65 and C66 explained on page 42).

As one or two conditions have to be met in order for the pump to start, multiple start-ups due to pipe losses can be avoided. So, we avoid waking up the pump unnecessarily or too often.

Figure 1.2 and 1.3 shows how the pump wakes up depending on J149 setting.

Important: Sleep frequency (J150 (Hz)) must be lower than the wake-up frequency (J157 (Hz)). In addition, sleep frequency must be higher than minimum frequency (F16=J119)

With J149 = 1, 11, or 21 (frequency) selected

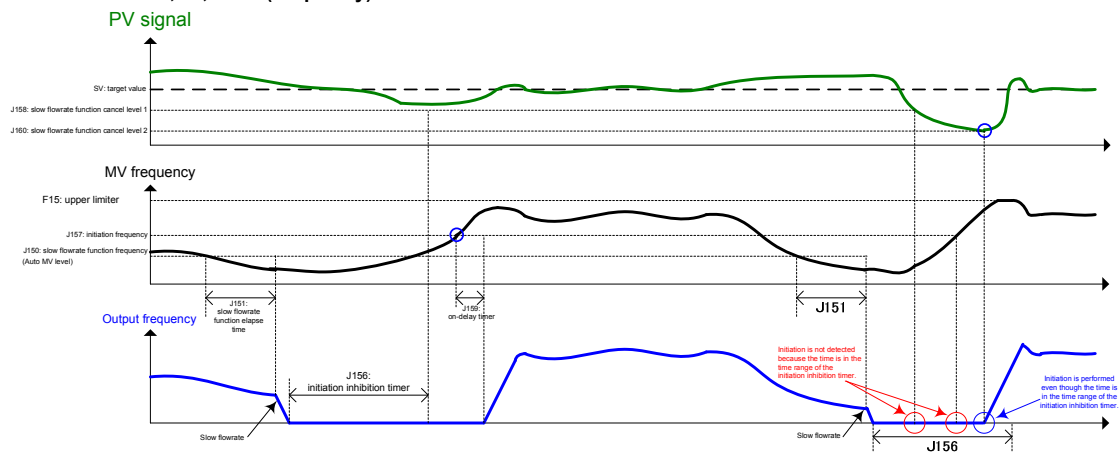

Figure 1.2: Speed control behaviour while sleep and wake-up functions are enabled and J14=1,11 or 21.

With J149 = 2, 12, or 22 (frequency) selected

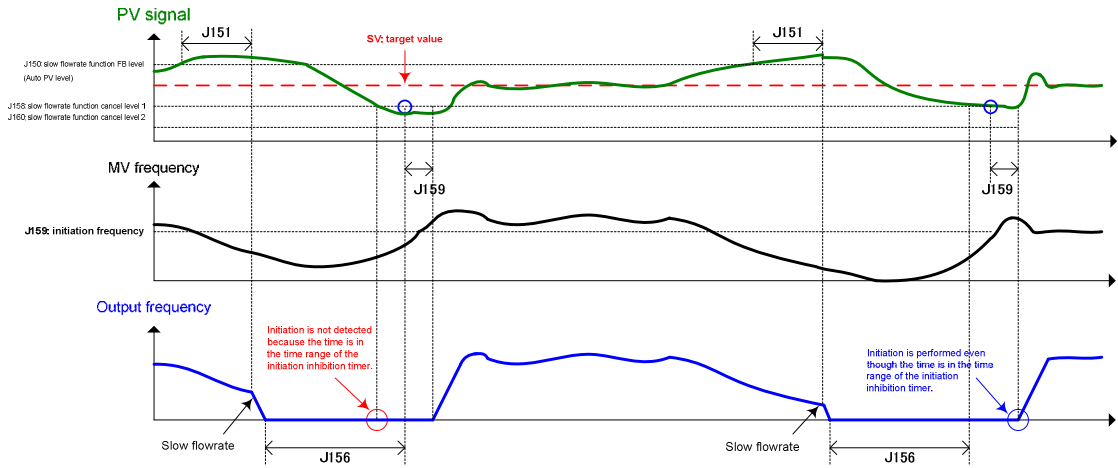

Figure 1.3: Speed control behaviour while sleep and wake-up functions are enabled and J14=2,12 or 22.

Function codes set-up, 1 pump

The following table (table 1.1), called “Common parameters to the all pump control systems”, shows the common parameters to all pump control systems using **Jaguar-VXA**, these are known as the basic parameters.

In other chapters, Specific Parameters’ table will be shown. These parameters will depend on the chosen control system.

Note: The following values are shown as an example and could not work properly in your application.

Table 1.1: Common parameters to all pump control systems

Common Parameters to all pump control systems				
	Name	Default setting	Example's Value	User's Value
F02	Run command	0	1	
F07	Acceleration Time 1	20.00 s	3.00 s	
F08	Deceleration Time 1	20.00 s	3.00 s	
F11	Electronic Thermal Overload protection. Overload detection Level	100% of the motor rated current	13.0 A	
F12	Electronic Thermal Overload protection. Time constant	5.0 min (22kW or below) 10.0 min (30kW or above)	5 min	
F15	Frequency Limiter. High	70.0 Hz	50.0 Hz	
F16	Frequency Limiter. Low	0.0 Hz	25.0 Hz	
C64	Analog input adjustment for terminal [C1]. Display unit	2: %	4: bar	
C65	Analog input adjustment for terminal [C1] (max. scale)	+ 100.00	Transducer's pressure	
K10	Main monitor display item selection	0: Speed monitor	50: SV	
K16	Sub monitor 1 display item selection	13: Output current	52: MV	
K17	Sub monitor 2 display item selection	19: Input power	51: PV	
E62	Terminal [C1] extended function	0	5	
P01	Motor. Number of Poles	4	4	
P02	Motor. Rated capacity	Rated Capacity Standard Motor	5.5 kW	
P03	Motor. Rated current	Rated Current Standard Motor	13.0 A	
H91	Current input wire break detection	0.0 s	0.5 s	
J101	PID Control 1. Mode Selection	0	1	
J110	PID Control 1. Gain P	0.100	2.500	
J111	PID Control 1. Integral time	0.0 s	0.2 s	
J118	PID Control 1. Upper limit of PID process output	Inherit	50.0 Hz	
J119	PID Control 1. Lower limit of PID process output	Inherit	25.0 Hz	
J149	Slow flow rate stop function. Mode selection	0	1: Manual operation (stop judgement MV)	
J150	Slow flow rate stop function. Sleep frequency	Auto	35.0 Hz	
J151	Slow flow rate stop stop function. Sleep frequency level latency	0 s	15 s	
J157	Slow flow rate stop function. Wake-up frequency	0 Hz	38.0 Hz	
J158	Slow flow rate stop function. Cancel deviation level 1	OFF	5 %	
J159	Slow flow rate stop function. Cancel delay timer	0 s	1 s	

CONDITIONS TO ACHIEVE GOOD CONTROL WITH A SINGLE PUMP

If it's necessary to use a different parameter set-up to that shown in the above “Example Values” column, please bear in mind the following conditions:

Sleeping/ Wake-up frequency Conditions

$$F03 = F15 = J118 > J157 > J150 > F16 = J119$$

Maximum frequency

Frequency to wake-up

Frequency to sleep

Minimum frequency

COMMON PARAMETERS DESCRIPTION

Basic Function

➤ F02: Run Command

This function code defines the way in what the “RUN” signal will be given to the inverter in order to start the pressure control.

Usually, “RUN Command” is sent to the inverter by means of the digital input (F02 = 1). That is, switching on FWD or REV (control terminals in the inverter) digital inputs enables the inverter output.

A RUN command can be also activated by means of the VXA keypad, pushing FWD or REV buttons.

- F07: Acceleration Time 1
- F08: Deceleration Time 1

These acceleration/deceleration ramps are used in two cases:

1. After the RUN Command is ON, F07 ramp is used to achieve the frequency in F16 or J119 (the biggest one of both values).
When the RUN Command is switched OFF, F08 value defines the deceleration ramp to go from the current frequency to the stop frequency (F25).
At every change of output frequency, even due to the PID output change.
2. These ramps are also used when the inverter is connected/disconnected from the commercial power supply if function codes J455 and J458 are set to 0.00 (please refer to the corresponding diagrams in the following chapters).

- F11: Electronic Thermal Overload Protection. Overload detection level
- F12: Electronic Thermal Overload Protection. Thermal time constant

By means of these two parameters is possible to adjust the overload protection function. Normally, F11 will be adjusted to the motor's rated current and F12 to 5 minutes.

- F15: Frequency Limiter. High
- F16: Frequency Limiter. Low

These two parameters define the frequency limits, and the inverter will never go outside of these limits during pump control.

It's normal to adjust the parameters F15, J118 and F03 with the same value. Equally, F16 should be equal to J119, too.

Inputs Set-up

- E62: Terminal [C1] extended function

This parameter can be used to select the function for analog input C1.

Usually this parameter is set to E62 = 5, this setting will define the [C1] analog input as PID Feedback (pressure transducer).

Motor Map

- P01: Motor. Number of poles
- P02: Motor. Rated Capacity
- P03: Motor. Rated Current

In these parameters must be stored the number of poles, rated capacity and rated current as are shown in the motor's nameplate.

Special Functions

> H91: Current input wire break detection

Disconnection of pressure sensor (cable failure).

When a value is stored in parameter H91 (between 0.1 and 60.0 seconds) the inverter will generate an alarm (**CoF**) when it notices that C1 signal current is missing (C1 current < 2mA) during a time longer than the value in H91.

H91 = OFF → function disabled.

H91 ≠ 0 → function enabled.

PID and pump control

> J101: PID control 1. Mode selection

When J101 = 1 and the error between Set Point and Process Value is positive (SP - PV > 0), the PID controller makes a positive output action control (increasing MV). Alternatively when the error between Set Point and Process Value is negative (SP - PV < 0), the PID controller makes a negative output action control (decreasing MV).

Alternatively, if J101 = 2 and the error between Set Point and Process Value is negative (SP - PV < 0) the PID controller makes a positive output action control (increasing MV). Alternatively when the error between Set Point and Process Value is positive (SP - PV > 0), the PID controller makes a negative output action control (decreasing MV).

> J110: PID Control 1. P Gain

This parameter is used to set the PID controller's proportional gain (P). This parameter must be adjusted because its value depends on the application.

A high P value produces a PID controller's quick response. Otherwise, a low P-value produces a slow response.

> J111: PID Control 1. Integral Time

This parameter is used to adjust PID's integral time (I). This parameter must be adjusted because its value depends on the application.

A high integral time value produces a PID slow response. Otherwise, a low I value produces a quicker response.

> J118: PID control 1. Upper limit of PID process output

> J119: PID control 1. Lower limit of PID process output

These parameters specify upper and lower limit process output values.

We set J118 = F15 = F03 and J119 = F16.

PID Control 2 is also available. Each function explained for PID Control 1 has an equivalent function in PID Control 2. For additional information, refer to **Jaguar-VXA** User Manual.

Chapter 2

Mono-regulated pump control with 1 regulated pump + 1, 2, 3 or 4 auxiliary pumps

Mono-regulated pump control (Mono-joker)			Necessary digital outputs	Do we need the optional relay card installed?
1 inverter driven pump	+	1 auxiliary pump (ON / OFF)	1	NO

The schematic for a mono-regulated pump control with 1 regulated pump + 1 auxiliary pump by means of the **Jaguar-VXA** inverter is as follows:

Please, pay attention to the pressure transducer's wiring, connected to the inverter's analog input C1 (4 – 20 mA).

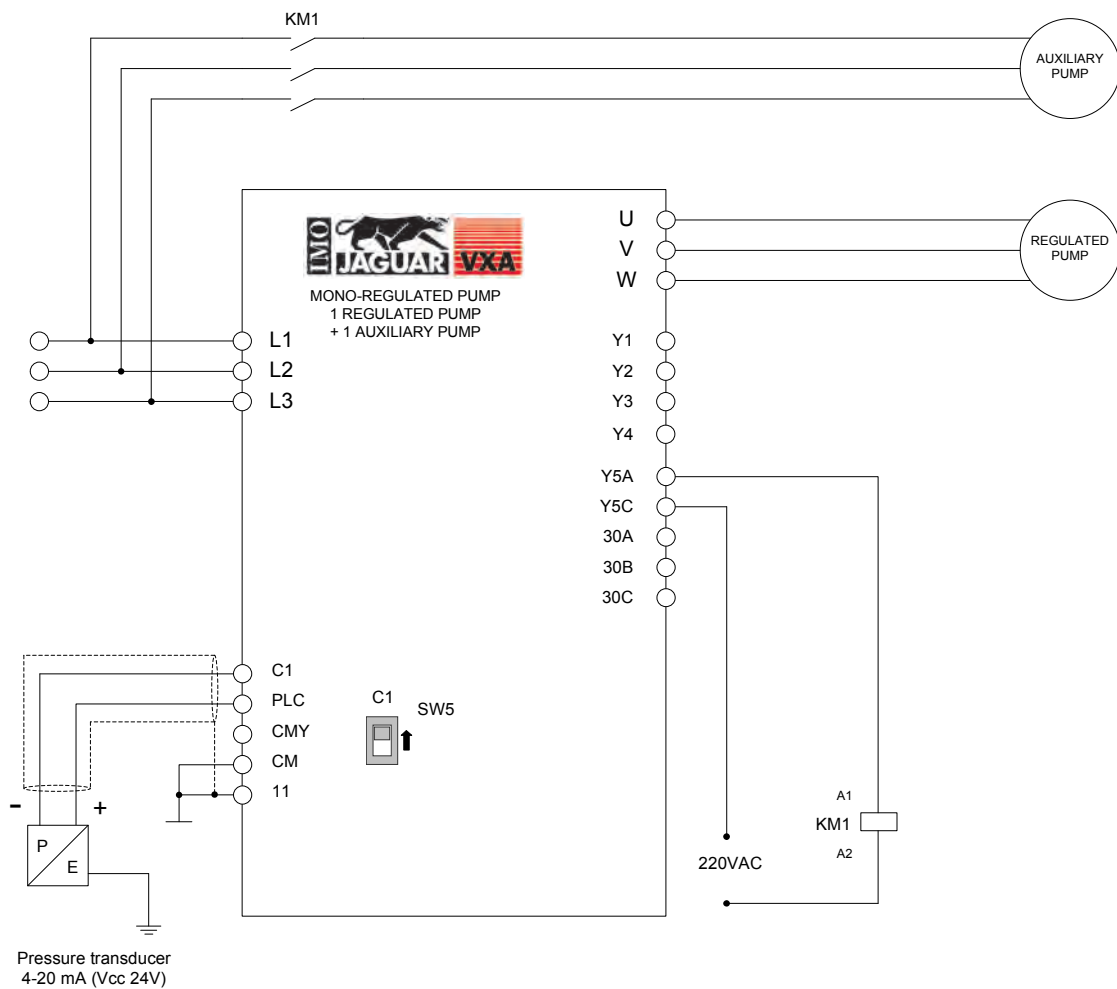

Figure 2.1: Schematic of a mono-regulated pump control with 1 regulated pump + 1 auxiliary pump.

Mono-regulated pump control (Mono-joker)			Necessary digital outputs	Do we need the optional relay card installed?
1 inverter driven pump	+	2 auxiliary pump (ON / OFF)	2	NO

The schematic for a mono-regulated pump control with 1 regulated pump + 2 auxiliary pumps by means of the inverter is as follows:

Please, pay attention to the pressure transducer's wiring, connected to the inverter's analog input C1 (4 – 20 mA)

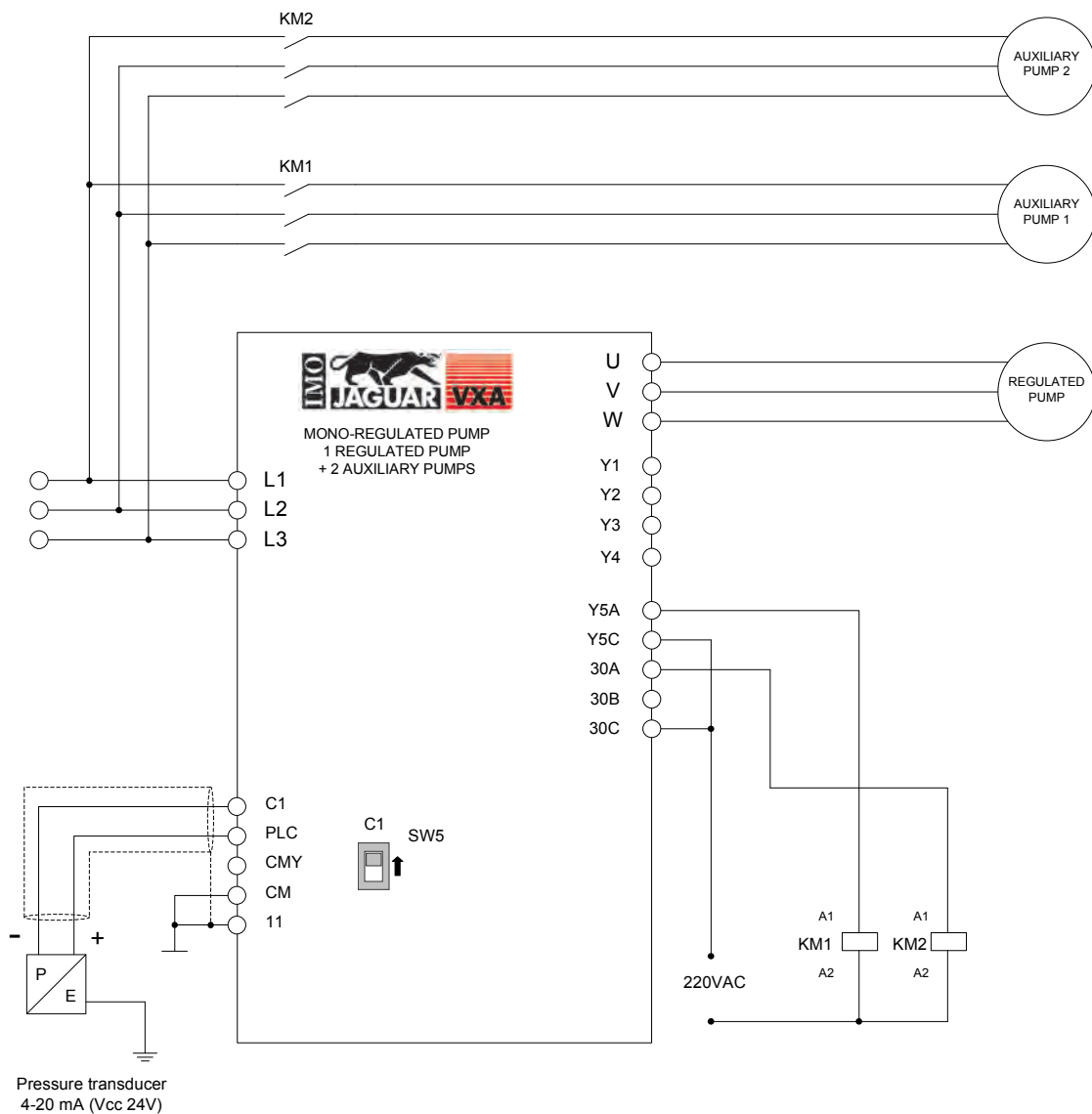

Figure 2.2: Schematic of a mono-regulated pump control with 1 regulated pump + 2 auxiliary pumps.

Mono-regulated pump control (Mono-joker)			Necessary digital outputs	Do we need the optional relay card installed?
1 inverter driven pump	+	3 auxiliary pump (ON / OFF)	3	YES (OPC-G1-RY)

The schematic for a mono-regulated pump control with 1 regulated pump + 3 auxiliary pumps by means of the **Jaguar-VXA** inverter is as follows:

Please, pay attention to the pressure transducer's wiring, connected to the inverter's analog input C1 (4 – 20 mA)

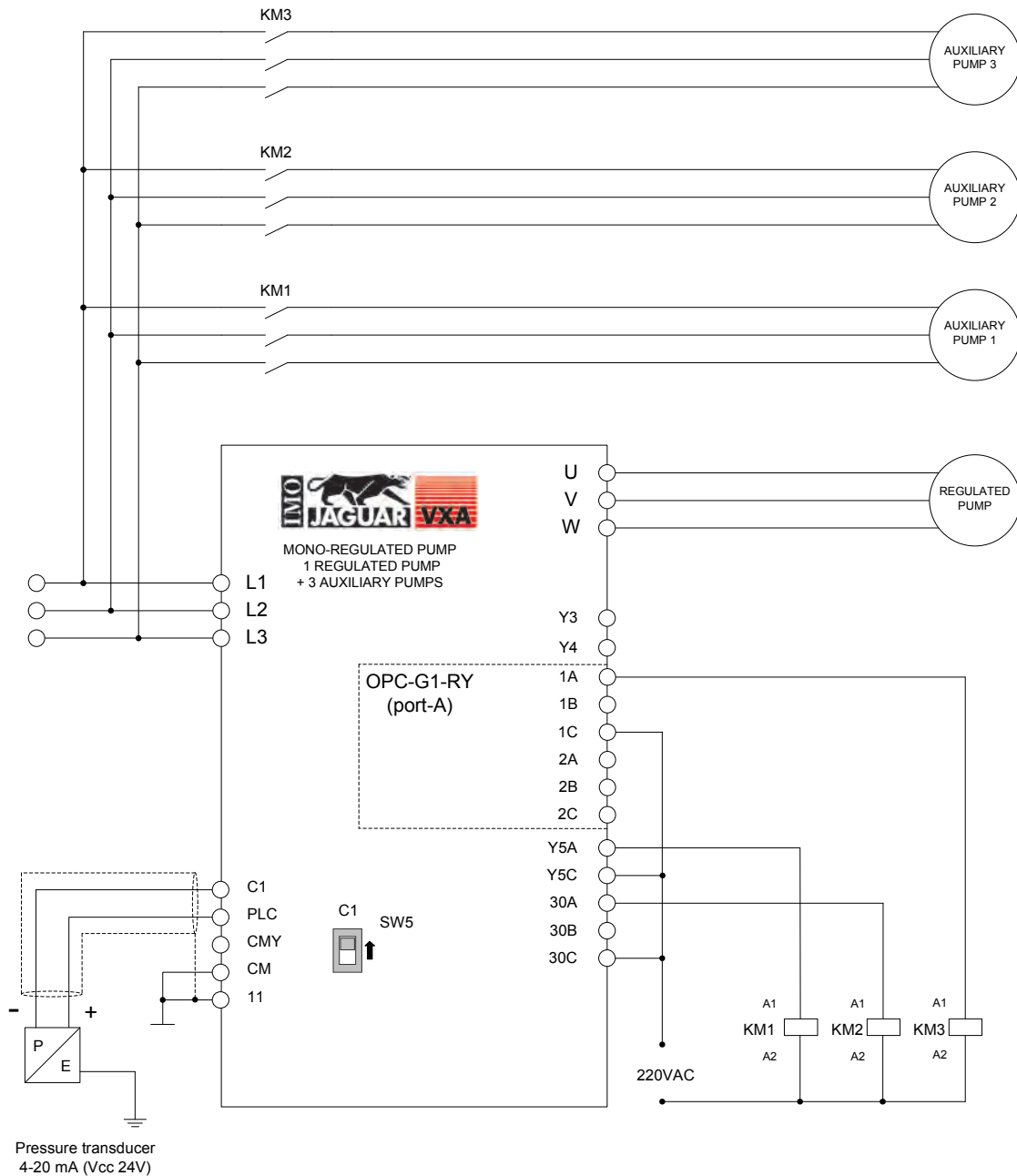

Figure 2.3: Schematic of a mono-regulated pump control with 1 regulated pump + 3 auxiliary pumps.

Mono-regulated pump control (Mono-joker)			Necessary digital outputs	Do we need the optional relay card installed?
1 inverter driven pump	+	4 auxiliary pump (ON / OFF)	4	YES (OPC-G1-RY)

The schematic for a mono-regulated pump control with 1 regulated pump + 4 auxiliary pumps by means of the **Jaguar-VXA** inverter is as follows:

Please, pay attention to the pressure transducer's wiring, connected to the inverter's analog input C1 (4 – 20 mA)

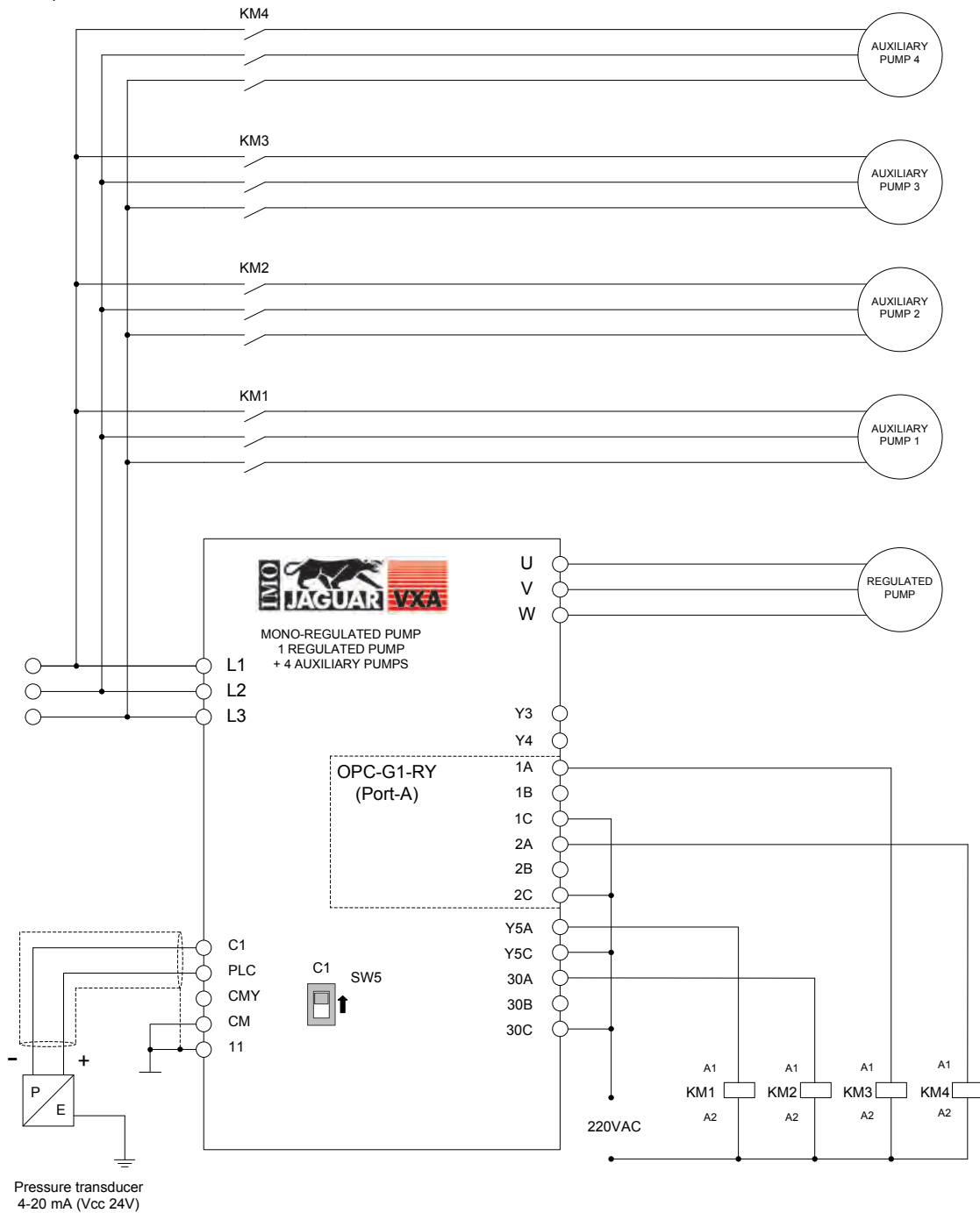

Figure 2.4: Schematic of a mono-regulated pump control with 1 regulated pump + 4 auxiliary pumps.

Mono-regulated pump control involves a pump exclusively driven by the inverter and other(s) pump(s), working in “On-Off control” mode and directly connected to the commercial power supply.

The inverter will connect/disconnect the auxiliary pump(s) to the commercial power supply, in order to achieve the desired pressure.

By means of the VXA keypad, digital input or analog command, the desired system pressure will be set. Then, the inverter will modify the speed of the regulated pump between the minimum frequency (J119 = F16) and a maximum frequency (J118 = F15 = F03), keeping the pressure under control.

The inverter’s PID control 1 must be activated (J101) and adjusted accordingly, ensuring the inverter’s response is what the installation requires all the time.

PID control 1 action can be adjusted by means of function codes J110 and J111 (proportional gain and integral time).

Connection/Disconnection of an auxiliary pump is shown in Figure 2.5, with all the related function codes.

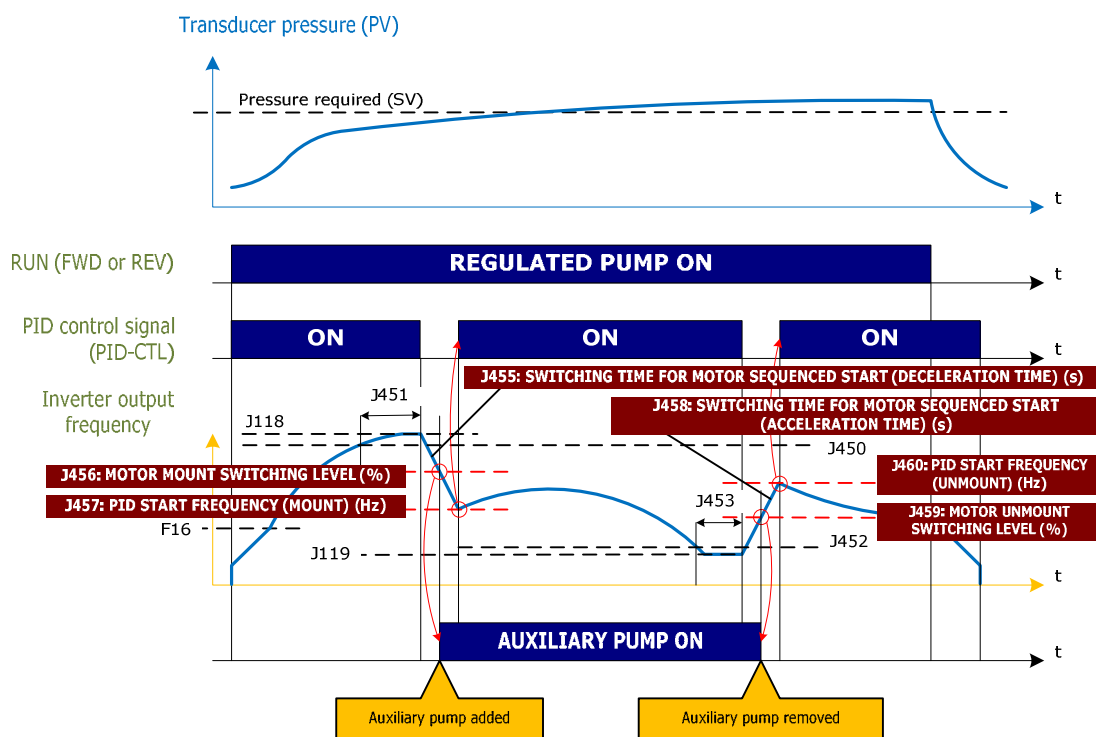

Figure 2.5: Speed pattern with mono-regulated pump control. The Auxiliary pump is connected and disconnected

The requirements or conditions to activate an auxiliary pump are described below:

• Connection of an auxiliary pump

1st stage

Conditions for adding an auxiliary pump

If the regulated pump's output frequency is higher than the level established by J450 during the time specified in J451, the inverter will understand that using the regulated pump is not enough to maintain the required pressure, and the inverter is ready to connect an auxiliary pump to the commercial power supply.

2nd stage

Adding an auxiliary pump

When the conditions above are accomplished, the inverter will decrease the output frequency of the regulated pump to the value stored in J457, by means of the deceleration ramp in J455. Once the frequency level J457 is achieved, the PID controller will be activated again. The frequency level when the auxiliary pumps are connected is defined in function code J456.

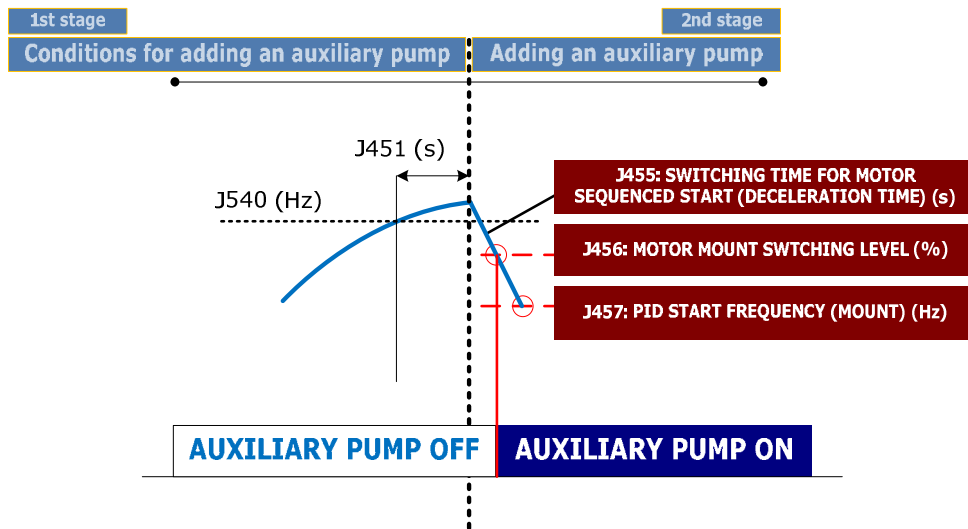

Figure 2.6: Auxiliary pump's connection

The exact frequency level where the inverter connects the auxiliary pumps to the commercial power supply is specified by means of the function code J456. The equation that defines this level is:

$$\text{Frequency for the connection of the auxiliary pumps (Hz)} = \left[\frac{J456}{100} \times (J118 - J119) \right] + J119$$

As an example:

J456 = 50 %
J118 = 50 Hz
J119 = 25 Hz



$$\text{Frequency for the connection of the auxiliary pumps (Hz)} = \left[\frac{50}{100} \times (50 - 25) \right] + 25 = 37,5 \text{ Hz}$$

In this case, the connection of the auxiliary pumps happens when the regulated pump is turning at 37.5 Hz.

The requirements or conditions to deactivate an auxiliary pump are described below:

- **Disconnection of an auxiliary pump**

1st stage **Conditions for removing an auxiliary pump**

If the output frequency level of the regulated pump gets lower than the value stored in J452 during a time longer than J453, the inverter will understand that the auxiliary pump is no longer needed and will begin a disconnection process.

2nd stage **Removing an auxiliary pump**

If the conditions above are accomplished, the inverter will increase the output frequency of the regulated pump until the frequency level specified by function code J460, by means of the acceleration ramp J458. The frequency level when the auxiliary pumps are disconnected is defined by function code J459.

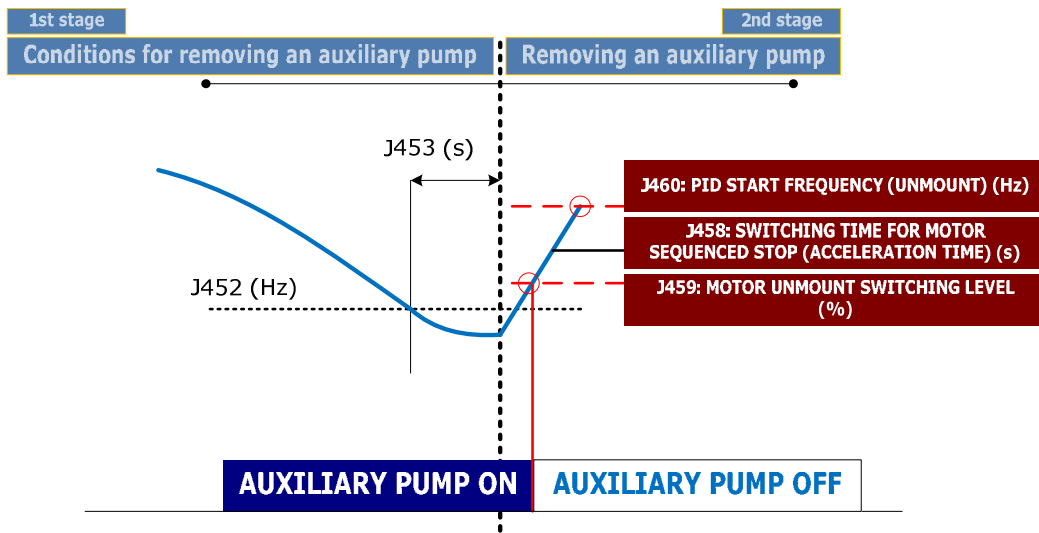

Figure 2.7: Disconnection of an auxiliary pump

The exact frequency level where the inverter disconnects the auxiliary pumps from the commercial power supply is specified by means of the function code J459. The equation that defines this level is:

$$\text{Frequency for the connection of the auxiliary pumps (Hz)} = \left[\frac{J459}{100} \times (J118 - J119) \right] + J119$$

For example:

J459 = 40 %
 J118 = 50 Hz
 J119 = 25 Hz



$$\text{Frequency for disconnection of the auxiliary pumps (Hz)} = \left[\frac{40}{100} \times (50 - 25) \right] + 25 = 35 \text{ Hz}$$

In this case, the disconnection of the auxiliary pumps happens when the regulated pump is turning at 35 Hz.

Set-up for 1 regulated pump + 1, 2, 3 or 4 auxilliary pumps

The following table (Table 2.1), "Common parameters to all the pump control systems", shows the common parameters to all of the control systems using **Jaguar-VXA** inverter. These are known as the basic parameters.

In addition to the following table, there is also a specific parameters table.

Note: The following values are shown as an example and may not necessarily work in your application

Table 2.1: Common parameters to all pump control systems

Common parameters to all of the pump control systems				
	Name	Default setting	Example's Value	User's Value
F02	RUN command	0	1	
F07	Acceleration time 1	20.00 s	3.00 s	
F08	Deceleration time 1	20.00 s	3.00 s	
F11	Electronic Thermal Overload protection. Overload detection Level	100% of the motor rated current	13.0 A	
F12	Electronic Thermal Overload protection. Time constant	5.0 min (22kW or below) 10.0 min (30kW or above)	5 min	
F15	Frequency Limiter. High	70.0 Hz	50.0 Hz	
F16	Frequency Limiter. Low	0.0 Hz	25.0 Hz	
C64	Analog input adjustment for terminal [C1]. Display unit	2: %	4: bar	
C65	Analog input adjustment for terminal [C1] (max. scale)	+ 100.00	Transducer's pressure	
K10	Main monitor display item selection	0: Speed monitor	50: SV	
K16	Sub monitor 1 display item selection	13: Output current	52: MV	
K17	Sub monitor 2 display item selection	19: Input power	51: PV	
E62	Terminal [C1] extended function	0	5	
P01	Motor. Number of poles	4	4	
P02	Motor. Rated Capacity	Rated capacity of standard motor	5.5 kW	
P03	Motor. Rated Current	Rated current of standard motor	13.0 A	
H91	Current input wire break detection	0.0 s	0.5 s	
J101	PID Control 1. Mode selection	0	1	
J110	PID Control 1. Gain P	0.100	2.500	
J111	PID Control 1. Integral time	0.0 s	0.2	
J118	PID Control 1. Upper limit of PID process output	999	50.0 Hz	
J119	PID Control 1. Lower limit of PID process output	999	25.0 Hz	
J149	Slow flow rate stop function. Mode selection	0	1: Manual operation (stop judgement MV)	
J150	Slow flow rate stop function. Sleep frequency	0 Hz	35.0 Hz	
J151	Slow flow rate stop function. Sleep frequency level latency	30 s	15 s	
J157	Slow flow rate stop function. Wake-up frequency	0 Hz	38.0 Hz	
J158	Slow flow rate stop function. Cancel deviation level 1	0 %	5 %	
J159	Slow flow rate stop function. Cancel delay timer	0 s	1 s	

CONDITIONS TO ACHIEVE GOOD CONTROL IN A MONO-REGULATED PUMP CONTROL

The code values should meet the following conditions in order to achieve stable operational behaviour.

Conditions for Sleep/Wake-up frequency

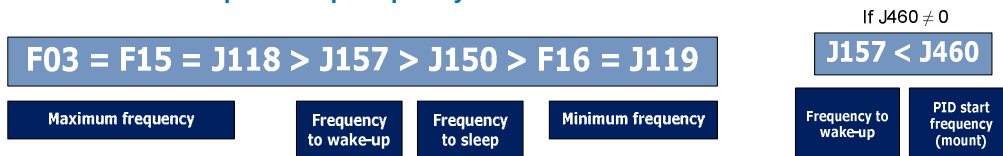

Conditions for the frequencies that define when auxiliary pumps are connected/disconnected

$$F03 = F15 = J118 > J450 > J452 > F16 = J119$$

Maximum frequency

Sequenced
start of
commercial
power-driven
motor

Sequenced
stop of
commercial
power-driven
motor

Minimum frequency

The function codes J450, J452 and J460 belong to specific function codes group and will be explained below.

The following table (Table 2.2) shows the specific function codes for a good control system with 1 regulated pump + 1, 2, 3, or 4 auxiliary pumps:

Table 2.2: Function codes for mono-regulated pump control with 1 regulated pump + 1, 2, 3 or 4 auxiliary pumps

Specific Function Codes , mono-regulated pump control with 1 regulated pump + 1, 2, 3 or 4 auxiliary pumps						
Name	Default Setting	For 1 auxiliary pump	For 2 auxiliary pumps	For 3 auxiliary pumps	For 4 auxiliary pumps	User's setting
E20	Status Signal Assignment to 1A/B/C (Y1)	0	0	0	165 (M3_L)	165 (M3_L)
E21	Status Signal Assignment to 1A/B/C (Y2)	1	1	1	1	167 (M4_L)
E24	Status Signal Assignment to Y5A/C	10	161 (M1_L)	161 (M1_L)	161 (M1_L)	161 (M1_L)
E27	Status Signal Assignment to 30A/B/C	99	99	163 (M2_L)	163 (M2_L)	163 (M2_L)
J401	Pump Control. Mode Selection	0	1	1	1	1
J411	Motor 1 Mode	0	1	1	1	1
J412	Motor 2 Mode	0	0	1	1	1
J413	Motor 3 Mode	0	0	0	1	1
J414	Motor 4 Mode	0	0	0	0	1
J450	Start of commercial power-driven motor.Frequency	999	48 Hz	48 Hz	48 Hz	48 Hz
J451	Start of commercial power-driven motor.Duration	0.00 s	5.00 s	5.00 s	5.00 s	5.00 s
J452	Stop of commercial power-driven motor.Frequency	999	30 Hz	30 Hz	30 Hz	30 Hz
J453	Stop of commercial power-driven motor.Duration	0.00 s	1.00 s	1.00 s	1.00 s	1.00 s
J459	Motor Unmount switching level	0 %	50 %	50 %	50 %	50 %
J456	Motor Mount Switching level	0 %	50 %	50 %	50 %	50 %
J457	PID Start Frequency (Mount)	0 Hz	40 Hz	40 Hz	40 Hz	40 Hz
J460	PID Start Frequency (Unmount)	0 Hz	39 Hz	39 Hz	39 Hz	39 Hz

Note: The default setting for function code J457 and J460 (Inherit) may work properly in your installation without adjusting it to the suggested value (40 Hz and 39 Hz respectively).

DESCRIPTION OF THE SPECIFIC FUNCTION CODES FOR MONO-REGULATED PUMP CONTROL

Outputs Set-up

- E20, E21, E24, E27, o01 to o07: Signal status assignment to 1 A/B/C (Y1 or Y3) 2 A/B/C (Y2 or Y4), Y5A/C, 30A/B/C and 6 A/C to 12 A/C

Function codes E20, E21, E24, E27 and from o01 to o07 define the function that will be assigned to terminals 1 A/B/C (Y1 or Y3), 2 A/B/C (Y2 or Y4), Y5A/C, 30A/B/C and from 6 A/C to 12 A/C respectively.

In a mono-regulated pump control system these outputs must be set in order to connect / disconnect the auxiliary pumps to the commercial power supply (functions 161: pump 1 to commercial power supply, 163: pump 2 to the commercial power supply, 165: pump 3 to commercial power supply and 167 pump 4 to commercial power supply, 167: pump 4 to commercial power supply, 169: pump 5 to commercial power supply, 171: pump 6 to commercial power supply, 173: pump 7 to commercial power supply, 175: pump 8 to commercial power supply).

PID and Pump control

➤ J401: Pump control. Mode Selection

Function code J401 defines the type of pump control that will be performed.

J401 = 0 Pump Control Disabled

J401 = 1 Mono-regulated pump Control Enabled

J401 = 2 Multi-regulated pump Control Enabled

➤ J411, J412, J413, J414, J415, J416, J417, J418: Motor 1 mode, Motor 2 mode, Motor 3 mode, Motor 4 mode, Motor 5 mode, Motor 6 mode, Motor 7 mode, Motor 8 mode.

Function codes J411, J412, J413, J414, J415, J416, J417 and J418 define:

 J411 = 0 Pump 1 unavailable
J411 = 1 Pump 1 available
J411 = 2 Pump 1 connected to commercial power supply

 J412 = 0 Pump 2 unavailable
J412 = 1 Pump 2 available
J412 = 2 Pump 2 connected to commercial power supply

 J413 = 0 Pump 3 unavailable
J413 = 1 Pump 3 available
J413 = 2 Pump 3 connected to commercial power supply

 J414 = 0 Pump 4 unavailable
J414 = 1 Pump 4 available
J414 = 2 Pump 4 connected to commercial power supply

 J415 = 0 Pump 5 unavailable
J415 = 1 Pump 5 available
J415 = 2 Pump 5 connected to commercial power supply

 J416 = 0 Pump 6 unavailable
J416 = 1 Pump 6 available
J416 = 2 Pump 6 connected to commercial power supply

 J417 = 0 Pump 7 unavailable
J417 = 1 Pump 7 available
J417 = 2 Pump 7 connected to commercial power supply

 J418 = 0 Pump 8 unavailable
J418 = 1 Pump 8 available
J418 = 2 Pump 8 connected to commercial power supply

In normal operation, the mode to be used is 1.

The other modes can be useful in the following situations:

- Mode 0: The pump will be omitted. Can be useful to disconnect, software disabled, a pump from the pump control system, without modifying the current wiring.
- Mode 2: Can be useful to check the rotation direction of the pump, because the pump will be connected to the commercial power supply as soon as this mode is activated.



ATTENTION

If the mode 2 is set in any of the function codes J411 to J418, the corresponding pump will begin to rotate at the speed defined by the commercial power supply. Take the necessary measures.

Chapter 3

Mono-regulated pump control with 1 regulated pump + 4 auxiliary pumps + 1 additional pump

Mono-regulated pump control (Mono-joker)				Necessary digital outputs	Do we need the optional relay card installed?	
1 regulated pump	+	4 auxiliary pumps (On-Off control)	+	1 additional pump (On-Off control)	5	YES (OPC-G1-RY2)

The schematic to implement a mono-regulated pump control with 1 regulated pump + 4 auxiliary pumps + 1 additional pump with a **Jaguar-VXA** inverter is as follows:
Please, pay attention on the pressure transducer's wiring, connected to the inverter's analog input C1 (4 – 20 mA).

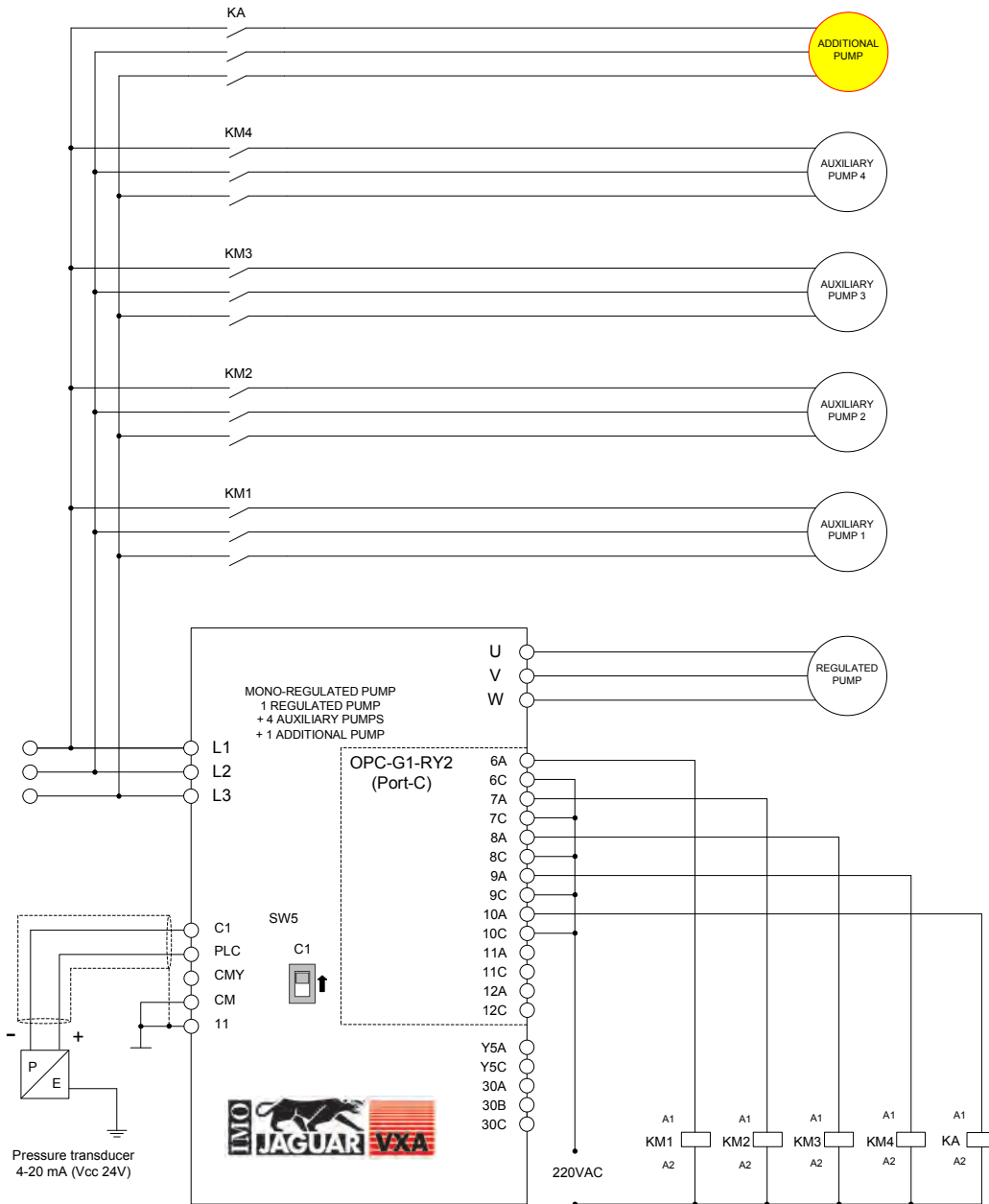

Figure 3.1: Schematic for a mono-regulated pump control with 1 regulated pump + 4 auxiliary pumps + 1 additional pump

This control system consists on a regulated pump controlled exclusively by the inverter and other 5 pumps working in “On-Off control” mode connected directly to the commercial power supply (4 auxiliary pumps + 1 additional pump). The inverter will connect/disconnect the auxiliary pumps to the commercial power supply in order to achieve the desired pressure.

The additional pump will be connected to the commercial power supply if the following two conditions are fulfilled:

1. All the auxiliary pumps that are enabled at this moment are connected to the commercial power supply, and
2. The regulated pump’s frequency is higher than the value stored in J565 (Hz).

The additional pump will be disconnected from the commercial power supply when:

Output frequency \leq (J565 – J466)

Using this control, the **Jaguar-VXA** inverter is able to control up to 10 pumps.

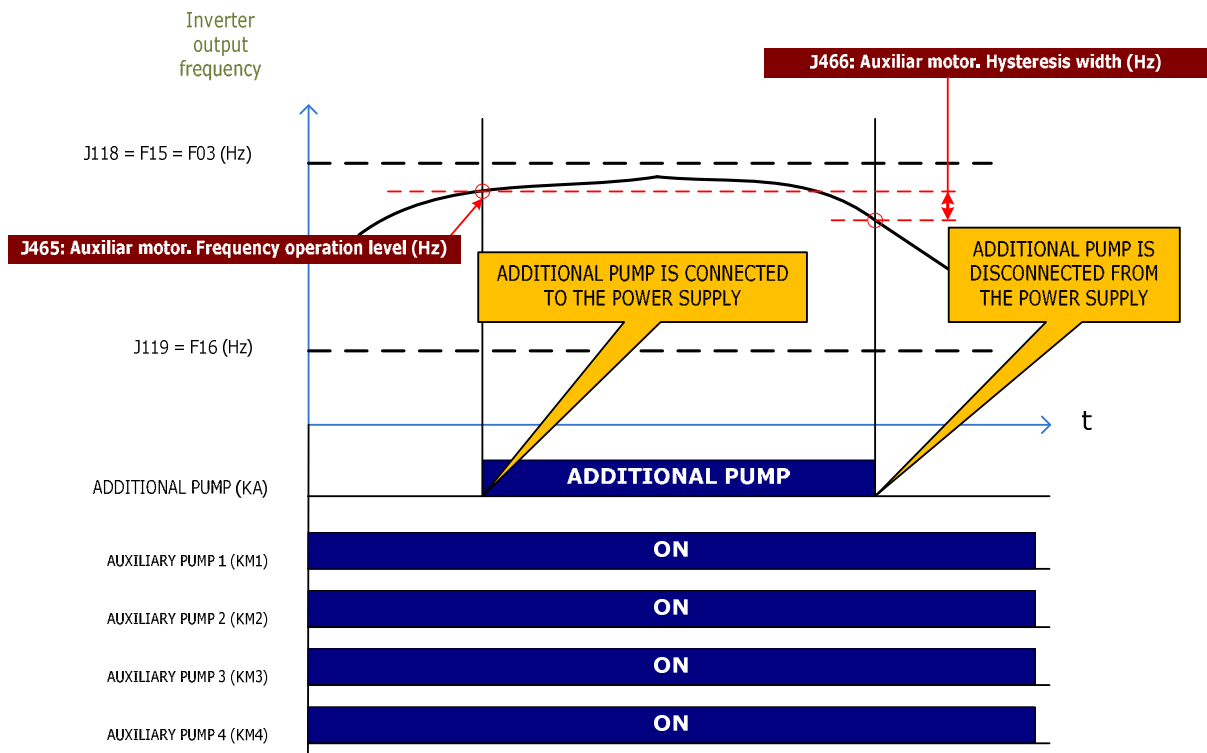

Figure 3.2: Additional pump's connection/disconnection diagram if all the auxiliary pumps are enabled

Set-up with 1 regulated pump + 4 auxiliary pumps + 1 additional pump

The following table (Table 3.1), called “Common parameters to all the pump control systems”, shows the common parameters to all of the control systems using the **Jaguar-VXA** inverter, these are the basic parameters.

Additional to the common function codes’ table, there is also a table with specific function codes.

Note: The following values are only an example, and may not necessarily work in your application.

Table 3.1: Common parameters to all the pump control systems

Common parameters to all the pump control systems				
	Name	Default Setting	Example’s value	User’s Value
F02	RUN command	0	1	
F07	Acceleration time 1	20.00 s	3.00 s	
F08	Deceleration time 1	20.00 s	3.00 s	
F11	Electronic Thermal Overload protection. Overload detection Level	100% of the rated motor current	13.0 A	
F12	Electronic Thermal Overload protection. Time constant	5.0 min (22kW or below) 10.0 min (30kW or above)	5 min	
F15	Frequency Limiter. High	70.0 Hz	50.0 Hz	
F16	Frequency Limiter. Low	0.0 Hz	25.0 Hz	
C64	Analog input adjustment for terminal [C1]. Display unit	2: %	4: bar	
C65	Analog input adjustment for terminal [C1] (max. scale)	+ 100.00	Transducer’s pressure	
K10	Main monitor display item selection	0: Speed monitor	50: SV	
K16	Sub monitor 1 display item selection	13: Output current	52: MV	
K17	Sub monitor 2 display item selection	19: Input power	51: PV	
E62	Terminal [C1] extended function	0	5	
P01	Motor. Number of poles	4	4	
P02	Motor. Rated Capacity	Rated Capacity standard motor	5.5 kW	
P03	Motor. Rated Current	Rated current standard motor	13.0 A	
H91	Current input wire break detection	0.0 s	0.5 s	
J101	PID Control 1. Mode selection	0	1	
J110	PID Control 1. Gain P	0.100	2.500	
J111	PID Control 1. Integral time I	0.0 s	0.2	
J118	PID Control 1. Upper limit of PID process output	999	50.0 Hz	
J119	PID Control 1. Lower limit of PID process output	999	25.0 Hz	
J149	Slow flow rate stop function. Mode selection	0	1: Manual operation (stop judgement MV)	
J150	Slow flow rate stop function. Sleep frequency	0 Hz	35.0 Hz	
J151	Slow flow rate stop stop function. Sleep frequency level latency	30 s	15 s	
J157	Slow flow rate stop function. Wake-up frequency	0 Hz	38.0 Hz	
J158	Slow flow rate stop function. Cancel deviation level 1	0 %	5 %	
J159	Slow flow rate stop function. Cancel delay timer	0 s	1 s	

CONDITIONS TO ACHIEVE GOOD CONTROL WITH A MONO-REGULATED PUMP CONTROL + 4 AUXILIARY PUMPS + 1 ADDITIONAL PUMP

If setting function codes’ values different from the “Example’s Value” column, it is recommended to keep in mind the following restrictions:

Conditions for Sleep/Wake-up frequency

$$F03 = F15 = J118 > J157 > J150 > F16 = J119$$



If J460 ≠ 0

$$J157 < J460$$



Conditions for the frequencies that define when auxiliary pumps are connected/disconnected

$$F03 = F15 = J118 > J450 > J452 > F16 = J119$$



Conditions for the connection of the additional pump

$$J465 \approx J450$$

$$J465 - J466 \approx J452$$

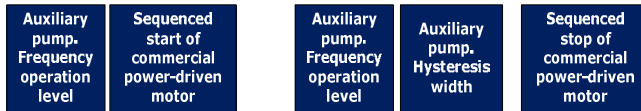

Using this control topology, it can be necessary to delay the disconnection of the motor from the commercial power supply (J453), in order to prevent the simultaneous disconnection of the auxiliary and the additional pumps. That is, the first pump to be disconnected should be the additional pump and then the auxiliary pump, but never at the same time.

The following table (Table 3.2) shows the specific function codes to successfully control a mono-regulated pump control system with 1 regulated pump + 4 auxiliary pumps + 1 additional pump:

Table 3.2: Specific function codes for Mono-regulated pump control with 1 regulated pump + 4 auxiliary pumps + 1 additional pump

Specific Function Codes for mono-regulated pump control with 1 regulated pump + 4 auxiliary pumps + 1 additional				
	Name	Default Setting	Example's value	User's value
o01	Status Signal Assignment to 6 A/C (OPC-G1-RY2)	6	161 (M1_L)	
o02	Status Signal Assignment to 7 A/C (OPC-G1-RY2)	10	163 (M2_L)	
o03	Status Signal Assignment to 8 A/C (OPC-G1-RY2)	25	165 (M3_L)	
o04	Status Signal Assignment to 9 A/C (OPC-G1-RY2)	26	167 (M4_L)	
o05	Status Signal Assignment to 10 A/C (OPC-G1-RY2)	28	88 (AUX_L)	
J401	Pump Control. Mode Selection	0	1	
J411	Motor 1 mode	0	1	
J412	Motor 2 mode	0	1	
J413	Motor 3 mode	0	1	
J414	Motor 4 mode	0	1	
J450	Start of commercial power-driven motor. Frequency	999	48 Hz	
J451	Start of commercial power-driven motor. Duration	0.00 s	5.00 s	
J452	Stop of commercial power-driven motor. Frequency	999	30 Hz	
J453	Stop of commercial power-driven motor. Duration	0.00 s	1.00 s	
J459	Motor Unmount switching Level	0 %	50 %	
J456	Motor Mount switching Level	0 %	50 %	
J457	PID Start Frequency (Mount)	0 Hz	40 Hz	
J460	PID Start Frequency (Unmount)	0 Hz	39 Hz	
J565	Auxiliary Motor (Frequency operation level)	50.0 Hz	47.0 Hz	
J466	Auxiliary Motor (Hysteresis width)	1.0 Hz	8.0 Hz	

Note: The default setting for function code J457 and J460 (0 Hz) may work properly in your installation without adjusting it to the suggested value (40 Hz and 39 Hz respectively).

DESCRIPTION OF SPECIFIC PARAMETERS FOR A MONO-REGULATED PUMP CONTROL + 4 AUXILIARY PUMPS + 1 ADDITIONAL PUMP

Outputs Set-up

- o05: Status Signal Assignment to 10 A/C (OPC-G1-RY2)

The function code o05 defines the signal assigned to relay output 10 A/C.

In order to implement a mono-regulated pump control system with an additional pump, the 10 A/C terminal's signal must be set to 88, corresponding to AUX_L function.

If all the pumps that are enabled (using parameters J411-J414) have been activated (they are active due to the state of the system), by means of AUX_L function it is possible to activate an extra digital output 10 A/C when the regulated pump's output frequency raises above the frequency level defined in the function code J565.

In this function, one pump is considered "enabled" when the two conditions below are accomplished at the same time:

- If MEN# is assigned to any digital input, this digital input must be ON (where # is the number of the motor). If MEN# is not assigned to any digital input, this condition will always be true.
- If the parameter, within J411-J414 range, corresponding to this pump is different from zero

In the picture below (Figure 3.3) this function logic block is depicted:

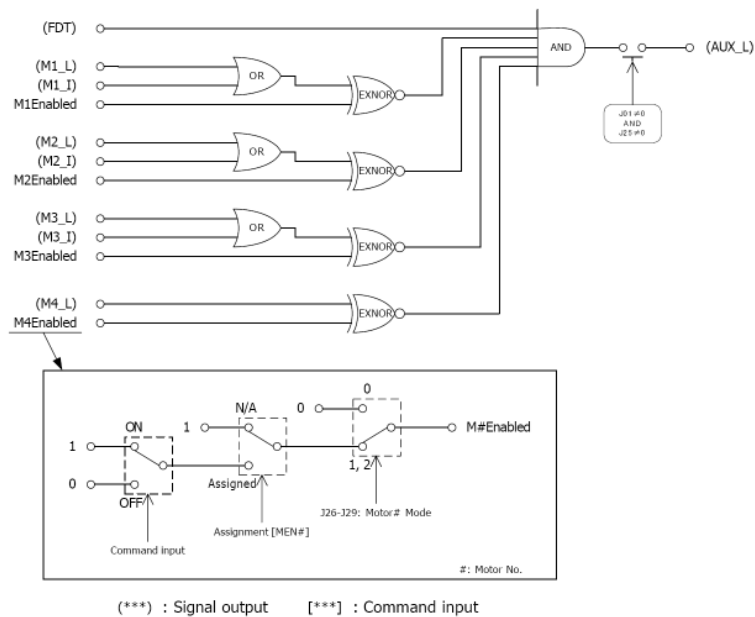

Figure 3.3: Additional pump function logic block diagram

Using function code J466 it is possible to define a hysteresis, for deactivating the pump below certain level of frequency and in order to avoid the signal 10 A/C activating/deactivating constantly.

➤ J565: Auxiliary Motor (Frequency operation level)

This function code defines the detection level where AUX_L function can be activated. That is, if the output frequency is higher than this level, the output with the AUX_L function assigned (88) will be activated. The level configured in J565 must be similar to the value of J450.

➤ J466: Auxiliary Motor (Hysteresis width)

With this parameter it is possible to adjust the hysteresis level for the deactivation of the AUX_L accordingly. The result of J565-J466 must be similar to the value of J452.

Chapter 4

Multi-regulated pump control with 2 / 3 regulated pumps

Multi-regulated pump Control (Multi-Joker)	Necessary digital outputs	Do we need the optional relay card installed?
2 Regulated pumps	4	YES (OPC-G1-RY)

The schematic to implement a multi-regulated pump control with 2 regulated pumps by means of **Jaguar-VXA** inverter is as follows:

Please, pay attention on the pressure transducer's wiring, connected to the inverter's analog input C1 (4 – 20 mA).

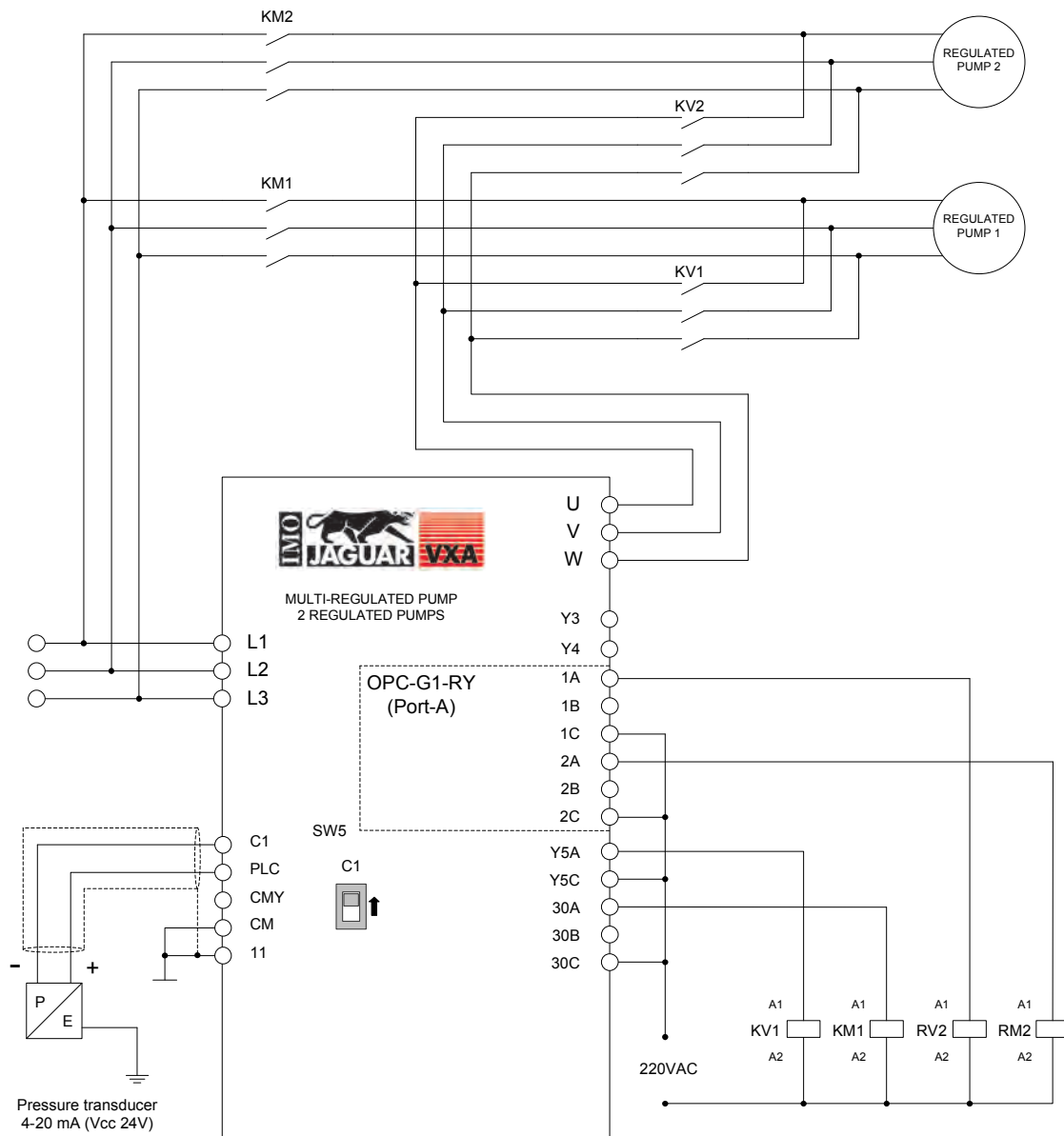

Figure 4.1: Schematics of multi-regulated pump control with 2 regulated pumps

Multi-regulated pump control (Multi-Joker)	Necessary digital outputs	Do we need the optional relay card installed?
3 regulated pumps	6	YES (OPC-G1-RY2)

The schematic to implement a multi-regulated pump control with 3 regulated pumps by means of **Jaguar-VXA** inverter is as follows:

Please, pay attention on the pressure transducer's wiring, connected to the inverter's analog input C1 (4 – 20 mA).

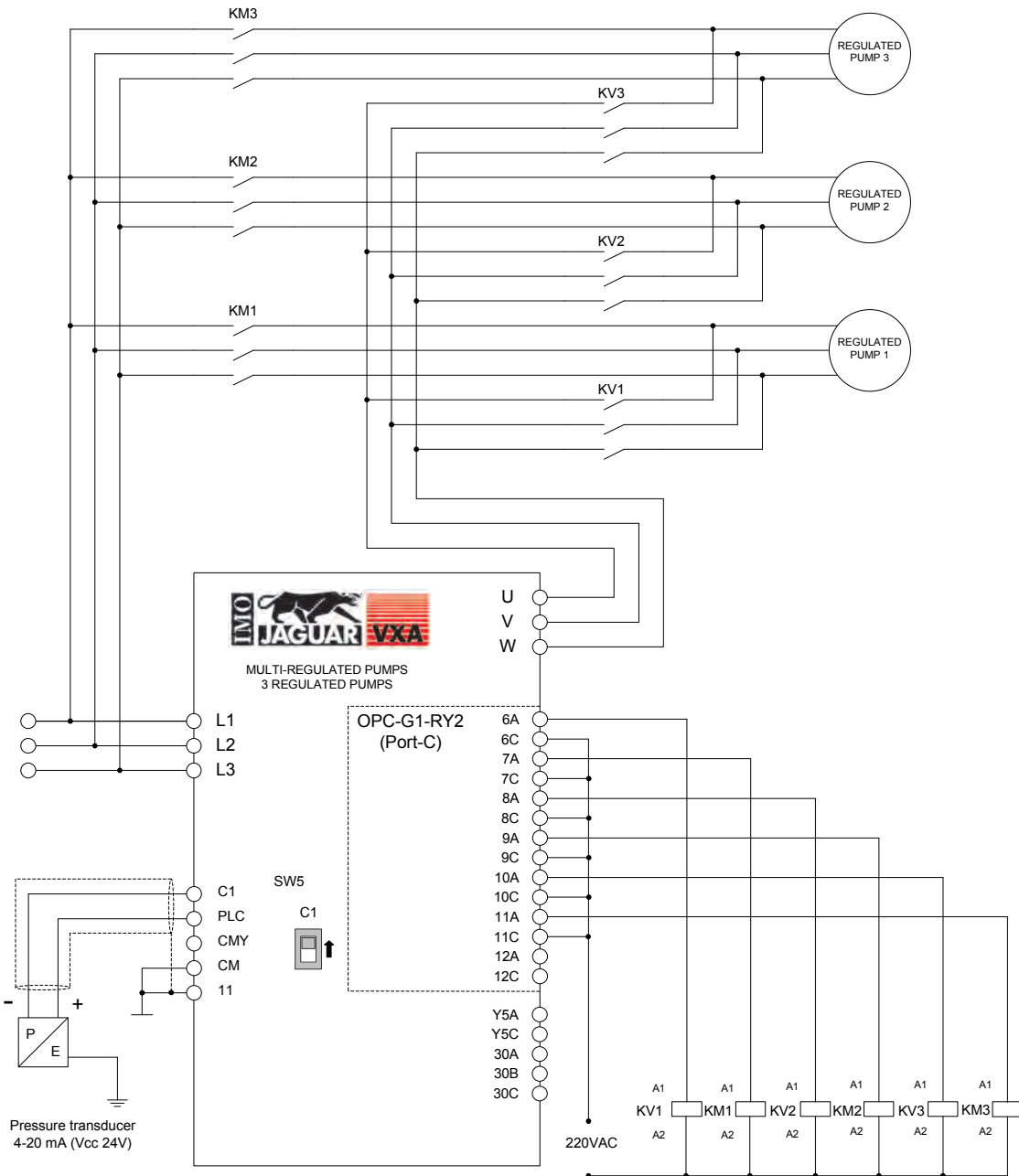

Figure 4.2: Schematics of multi-regulated pump control with 3 regulated pumps

This control consists of 2/3 pumps regulated by the inverter.

In Multi-regulated pump Control, all of the system pumps are driven by means of the inverter. The inverter controls the pump and connects/disconnects each pump to/from the commercial power supply according to the application requirements.

By means of the VXA keypad, digital inputs or analog command, the desired pressure will be set. Then, the inverter will modify the regulated pump's speed between the minimum frequency (J119 = F16) and the maximum frequency (J118 = F15 = F03), in order to keep the pressure under control.

To do this, the PID control 1 that comes with the inverter must be activated (J101) and must be adjusted properly, in order to provide an appropriate response in the installation.

The PID control 1 response can be modified by means of the function codes J110 and J111 (Proportional gain and integral time).

The Figure 4.3 shows the regulation of two pumps, where, if the pressure's demand increases and is not possible to satisfy it with 1 pump, the inverter will connect the pump 1 to the commercial power supply and will control of the second pump as a regulated one.

Similarly, if there is too much pressure, the inverter will disconnect pump 1 from the commercial power supply and will continue working only with pump 2 as a regulated one.

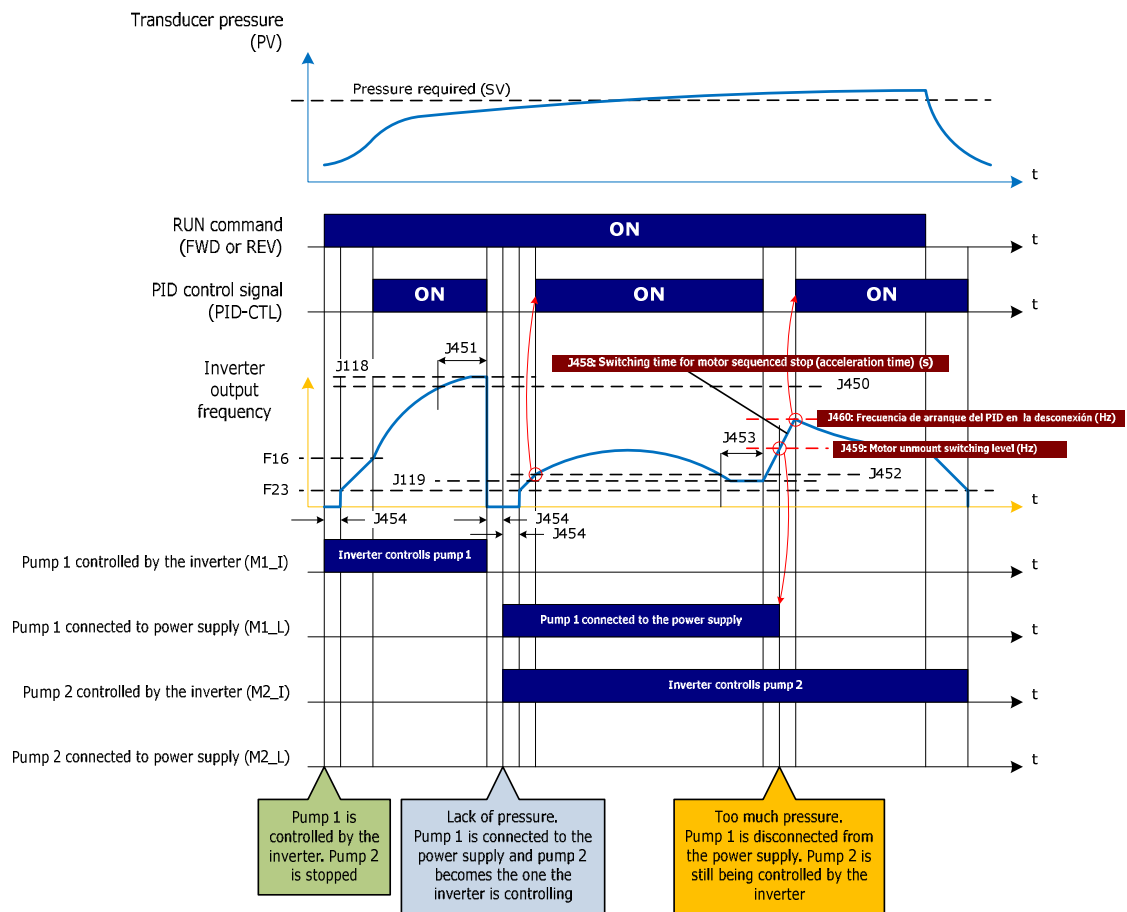

Figure 4.3: Speed pattern of a Multi-regulated pump Control with 2 regulated pumps

The following explanation describes the requirements or conditions to connect a regulated pump to the commercial power supply, and to disconnect a pump from the commercial power supply:

• Connection of a regulated pump to the main supply

1st stage

Requirements to connect a regulated pump to the power supply

If the regulated pump's output frequency rises above the level stored in J450 during the time established in J451, the inverter will understand that the regulated pump is not enough to maintain the required pressure and will get ready to connect the pump to the commercial power supply.

2nd stage

Connecting a regulated pump to the power supply

If the conditions above are accomplished, the inverter will connect the regulated pump to the commercial power supply and will take another pump of the system as a regulated one.

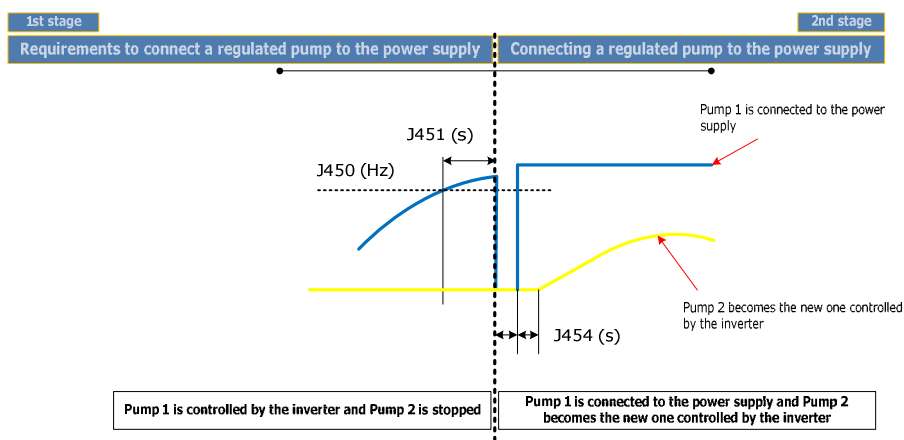

Figure 4.4: Connection of a regulated pump to the commercial power supply.

• Disconnection of a pump from the main supply

1st stage

Requirements to disconnect a pump connected to the power supply

If the regulated pump's output frequency decreases under the level established in function code J452 during the time J453, the inverter will understand that is not necessary to keep a pump connected to the commercial power supply and will get ready for its disconnection.

2nd stage

Disconnecting a pump from the power supply

If the conditions above are accomplished, the inverter will increase the regulated pump's output frequency until the frequency stored in J460 using the acceleration time in J458. Once the frequency level achieves this, the PID control 1 will be activated.

This behaviour can be useful to reduce the possible sudden pressure fluctuations that may occur when a pump is disconnected from the commercial power supply.

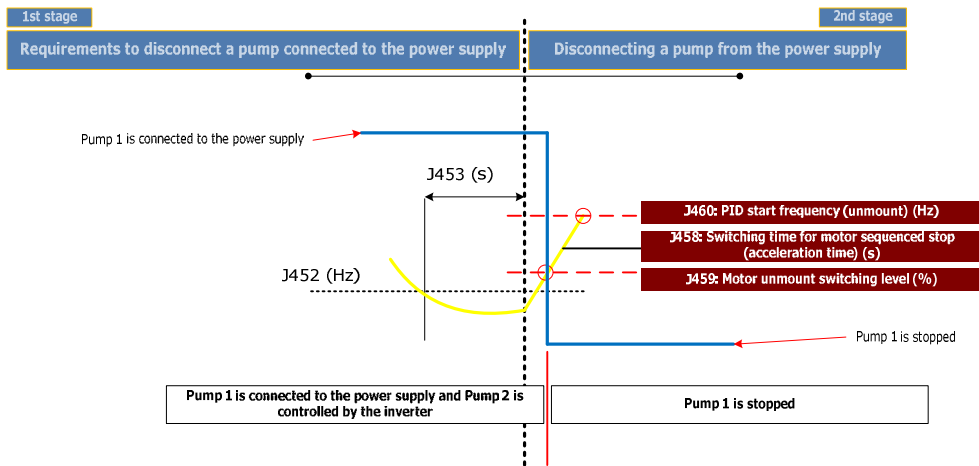

Figure 4.5: Increase of the pump's speed to disconnect the pump from the main supply

The exact point where the inverter will disconnect the pump from the main supply can be defined with function code J459. The equation to find this point is:

$$\text{Auxiliary pump's disconnection frequency (Hz)} = \left[\frac{J459}{100} \times (J118 - J119) \right] + J119$$

For example:

J459 = 40 %
 J118 = 50 Hz
 J119 = 25 Hz

$$\text{Auxiliary pump's disconnection frequency (Hz)} = \left[\frac{40}{100} \times (50 - 25) \right] + 25 = 35 \text{ Hz}$$

In this case, when the regulated pump is rotating at 35 Hz, the inverter will disconnect the pump from the main supply.

2 / 3 Regulated Pumps Set-Up

The following table (Table 4.1), called “Common Parameters to all the pump control systems”, shows the common parameters to all the control systems using the **Jaguar-VXA** inverter, these are the basic function codes.

In addition to the common function codes’ table, there is a table with the specific function codes.

Note: The following values are only an example, and may not necessarily work in your application.

Table 4.1: Common parameters to all pump control systems

Common Parameters to all the pump control systems				
	Name	Default setting	Example's Value	User's Value
F02	Run command	0	1	
F07	Acceleration Time 1	20.00 s	3.00 s	
F08	Deceleration Time 1	20.00 s	3.00 s	
F11	Electronic Thermal Overload protection. Overload detection Level	100% of the motor rated current	15.0 A	
F12	Electronic Thermal Overload protection. Time constant	5.0 min (22kW or below) 10.0 min (30kW or above)	5 min	
F15	Frequency Limiter. High	70.0 Hz	50.0 Hz	
F16	Frequency Limiter. Low	0.0 Hz	25.0 Hz	
C64	Analog input adjustment for terminal [C1]. Display unit	2: %	4: bar	
C65	Analog input adjustment for terminal [C1] (max. scale)	+ 100.00	Transducer's pressure	
K10	Main monitor display item selection	0: Speed monitor	50: SV	
K16	Sub monitor 1 display item selection	13: Output current	52: MV	
K17	Sub monitor 2 display item selection	19: Input power	51: PV	
E62	Terminal [C1] extended function	0	5	
P01	Motor. Number of Poles	4	4	
P02	Motor. Rated capacity	Rated Capacity Standard Motor	5.5 kW	
P03	Motor. Rated current	Rated Current Standard Motor	15.0 A	
H91	Current input wire break detection	0.0 s	0.5 s	
J101	PID Control 1. Mode Selection	0	1	
J110	PID Control 1. Gain P	0.100	2.500	
J111	PID Control 1. Gain I	0.0 s	0.2	
J118	PID Control 1. Upper limit of PID process output	Inherit	50.0 Hz	
J119	PID Control 1. Lower limit of PID process output	Inherit	25.0 Hz	
J149	Slow flow rate stop function. Mode selection	0	1: Manual operation (stop judgement MV)	
J150	Slow flow rate stop function. Sleep frequency	Auto	35.0 Hz	
J151	Slow flow rate stop function. Sleep frequency level latency	0 s	15 s	
J157	Slow flow rate stop function. Wake-up frequency	0 Hz	38.0 Hz	
J158	Slow flow rate stop function. Cancel deviation level 1	OFF	5 %	
J159	Slow flow rate stop function. Cancel delay timer	0 s	1 s	

CONDITIONS TO ACHIEVE GOOD CONTROL IN A MULTI-REGULATED PUMP CONTROL WITH 2/3 REGULATED PUMPS

Conditions for Sleep/Wake-up frequencies

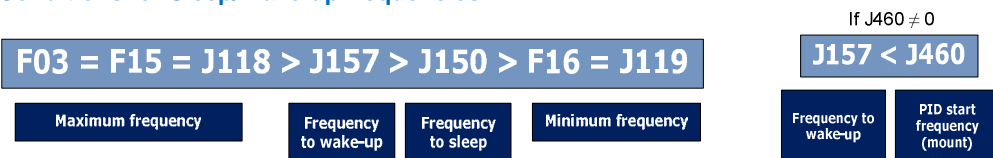

Conditions for the frequencies that define when auxiliary pumps are connected/disconnected

$$F03 = F15 = J118 > J450 > J452 > F16 = J119$$



The following table (table 4.2 and table 4.3) shows the specific function codes for multi-regulated pump control system with 2/3 regulated pumps:

Table 4.2: Specific parameters for Multi-regulated pump control with 2 regulated pumps

Specific Parameters for Multi-regulated pump control with 2 regulated pumps				
Name	Default value	For 2 regulated pumps (with OPC-G1-RY)	User's Value	
E20	Status Signal Assignment to 1 A/B/C (OPC-G1-RY)	0	162 (M2_I)	
E21	Status Signal Assignment to 2 A/B/C (OPC-G1-RY)	1	163 (M2_L)	
E24	Status Signal Assignment to Y5A/C	10	160 (M1_I)	
E27	Status Signal Assignment to 30A/B/C	99	161 (M1_L)	
J401	Pump Control. Mode Selection	0	2	
J411	Motor 1 Mode	0	1	
J412	Motor 2 Mode	0	1	
J450	Start of commercial power-driven motor.Frequency	999	48 Hz	
J451	Start of commercial power-driven motor.Duration	0.00 s	5.00 s	
J452	Stop of commercial power-driven motor.Frequency	999	30 Hz	
J453	Stop of commercial power-driven motor.Duration	0.00 s	1.00 s	
J459	Motor Unmount switching level	0 %	50 %	
J460	PID Start Frequency (Unmount)	0 Hz	39 Hz	

Table 4.3: Specific parameters for Multi-regulated pump control with 3 regulated pumps

Specific Parameters for Multi-regulated pump control with 3 regulated pumps				
Name	Default value	For 3 regulated pumps (with OPC-G1-RY2)	User's Value	
J401	Pump Control. Mode Selection	0	2	
J411	Motor 1 Mode	0	1	
J412	Motor 2 Mode	0	1	
J413	Motor 3 Mode	0	1	
J450	Start of commercial power-driven motor.Frequency	999	48 Hz	
J451	Start of commercial power-driven motor.Duration	0.00 s	5.00 s	
J452	Stop of commercial power-driven motor.Frequency	999	30 Hz	
J453	Stop of commercial power-driven motor.Duration	0.00 s	1.00 s	
J459	Motor Unmount switching level	0 %	50 %	
J460	PID Start Frequency (Unmount)	0 Hz	39 Hz	
o01	Status Signal Assignment to 6 A/C (OPC-G1-RY2)	6	160 (M1_I)	
o02	Status Signal Assignment to 7 A/C (OPC-G1-RY2)	10	161 (M1_L)	
o03	Status Signal Assignment to 8 A/C (OPC-G1-RY2)	25	162 (M2_I)	
o04	Status Signal Assignment to 9 A/C (OPC-G1-RY2)	26	163 (M2_L)	
o05	Status Signal Assignment to 10 A/C (OPC-G1-RY2)	28	164 (M3_I)	
o06	Status Signal Assignment to 11 A/C (OPC-G1-RY2)	36	165 (M3_L)	

Note: The default setting for function code J460 (0 Hz) may work properly in your installation without adjusting it to the suggested value (39 Hz).

DESCRIPTION OF SPECIFIC PARAMETERS OF MULTI-REGULATED PUMP CONTROL WITH 2/3 or 4 REGULATED PUMPS

PID and pump control

➤ J401: Pump control. Mode selection

The function code J401 defines which type of pump control is going to be used

J401 = 0 Pump control disabled

J401 = 1 Mono-regulated pump control enabled

J401 = 2 Multi-regulated control enabled

➤ J411, J412, J413, J414: Motor 1 mode, Motor 2 mode, Motor 3 mode, Motor 4 mode.

The function codes J411, J412, J413, J414 define:

➤ J411 = 0 pump 1 unavailable
J411 = 1 pump 1 available
J411 = 2 pump 1 connected to the commercial power supply

➤ J412 = 0 pump 2 unavailable
J412 = 1 pump 2 available
J412 = 2 pump 2 connected to the commercial power supply

➤ J413 = 0 pump 3 unavailable
J413 = 1 pump 3 available
J413 = 2 pump 3 connected to the commercial power supply

➤ J414 = 0 pump 4 unavailable
J414 = 1 pump 4 available
J414 = 2 pump 4 connected to the commercial power supply

In normal operation, the mode to be used is 1.

The other modes can be useful for:

- Mode 0: The pump is omitted. Can be useful to disconnect, software disable, a pump from the system without modifying the wires.
- Mode 2: Can be useful to check the rotation direction of the pumps, because they will be connected to the commercial power supply as soon as this mode is activated.



ATTENTION

If mode 2 is set to any of the parameters from J411 to J414, the corresponding pump will be turned on and will rotate at the speed marked by the commercial power supply. Take all necessary precautions.

SPECIFIC PARAMETERS DESCRIPTION HAVING OPTIONAL CARD RELAY INSTALLED (OPC-G1-RY2)

PID and pump control

➤ o01, o02, o03, o04, o05 and o06: Status Signal Assignment to 6 A/C, 7 A/C, 8 A/C, 9A/C, 10A/C (modifying these function codes only makes sense when the OPC-G1-RY2 option card is installed in the inverter)

The function code o01, o02, o03, o04, o05 and o06 define the signal assignment to the outputs 6 A/C, 7 A/C, 8 A/C, 9A/C, 10A/C of the OPC-G1-RY2 option relay card.

In Multi-regulated pump control with 3 regulated pumps these digital outputs must be set correctly in order to connect/disconnect the 3 pumps to the inverter or to the commercial power supply (function 160: motor 1 inverter-driven, function 161: motor 1, commercial-power driven, function 162: motor 2 inverter-driven, function 163: motor 2 commercial-power driven, function 164: motor 3 inverter-driven and function 165: motor 3 commercial-power driven).

Chapter 5

Multi-regulated pump control with 3 regulated pumps + 1 additional pump

Multi-regulated pump Control (Multi-Joker)		Necessary digital outputs	Do we need the optional relay card installed?
3 regulated pumps	+	1 additional pump ("On-Off control")	YES (OPC-G1-RY2)

The schematic for a multi-regulated pump control with 3 regulated pumps + 1 additional pump by means of the **Jaguar-VXA** inverter is as depicted in figure 5.1.

Please, pay attention on the pressure transducer's wiring, connected to the inverter's analog input C1 (4 – 20 mA).

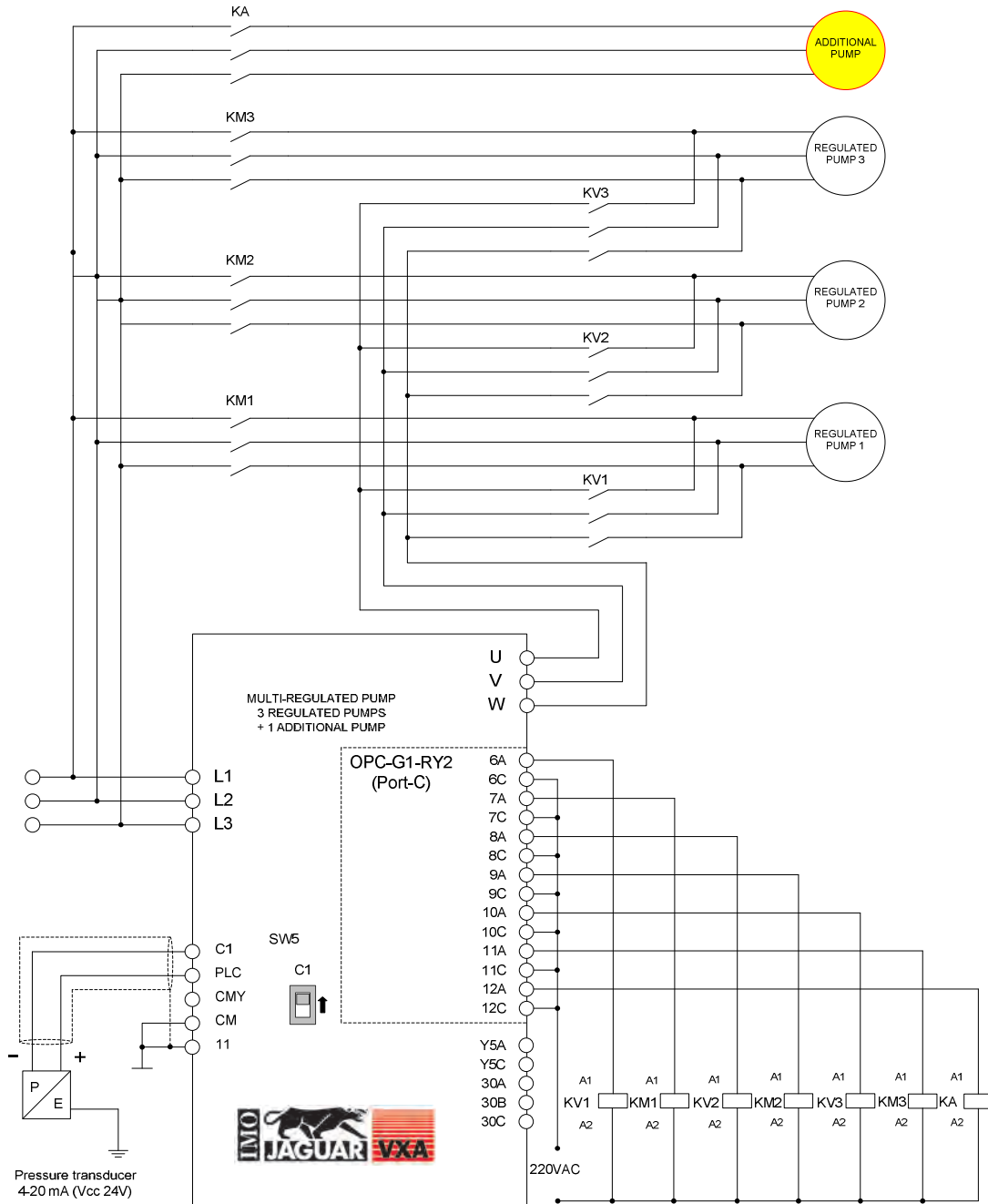

Figure 5.1: Schematic for multi-regulated pump control with 3 regulated pumps + 1 additional pump

In Multi-regulated pump Control, all the system pumps are regulated by means of the inverter. The inverter controls the pump and connects/disconnects each pump to/from the commercial power supply according to the application requirements.

The control system explained in this chapter consists of 3 pumps regulated by means of the inverter plus an additional pump working in “On-Off control” mode.

The additional pump will be connected to the commercial power supply if the following conditions are accomplished:

1. Two of the three system pumps are connected to the commercial power supply, and
2. The frequency of the pump that is regulated by the inverter is higher than the level configured in function code J565 (Hz).

The additional pump will be disconnected from the commercial power supply when:

Output frequency \leq (J565 – J466)

By means of this control system, **Jaguar-VXA** inverter is able to control up to 5 pumps.

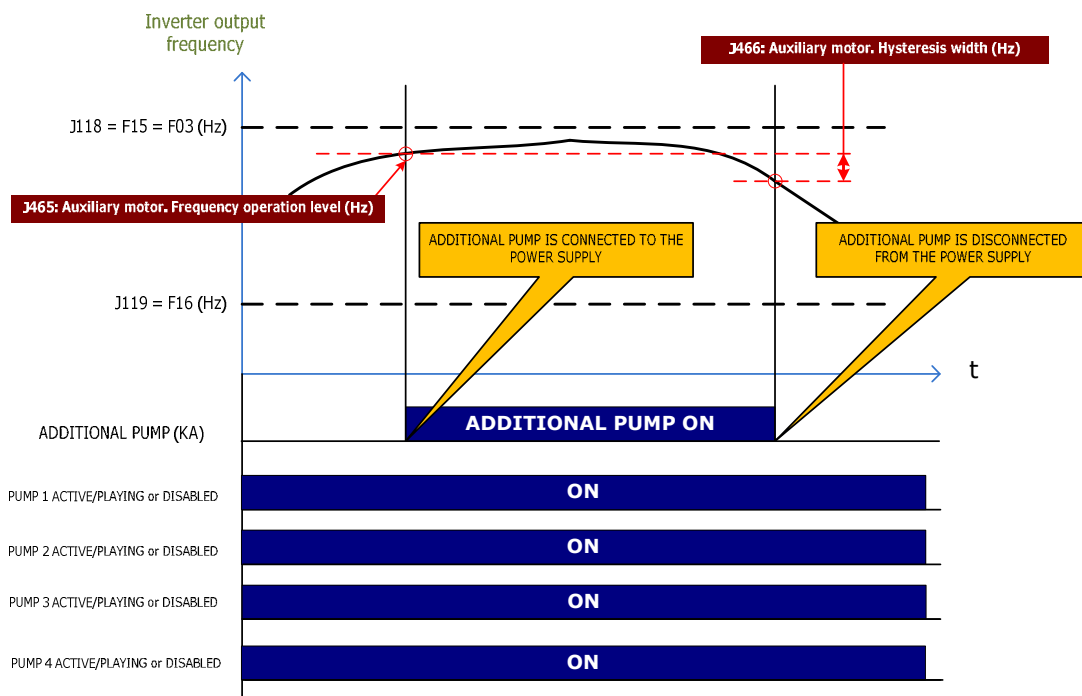

Figure 5.2: Additional pump connection/disconnection diagram if all the regulated pumps which are enabled are also active/playing

Note: In this case Active/playing means that the pump is either inverter driven or connected to the mains supply, depending on the state of the multi-regulated pump control.

In the same way as the multi-regulated pump control with 2,3 and 4 regulated pumps (chapter 4), if the pressure demand cannot be satisfied with only one pump, the inverter will connect it to the commercial power supply and pump 2 will become the new regulated pump.

If there is still not enough pressure, pump 2 will be connected to the main supply and pump 3 will become the new regulated pump. The same for the case of 4 pumps.

If there is still not enough pressure, the additional pump will be finally turned on.

But, if the pressure is too high, the inverter will disconnect the pumps connected to the commercial power supply.

3 regulated pumps + 1 additional pump Set-up

The following table (Table 5.1), called “Common parameters to all the pump control systems”, shows the common function codes to all the pump control systems using Jaguar-VXA inverter, these are the basic parameters.

Additional to the common parameters table, there is also a specific parameters table.

Note: The following values are only an example, and may not necessarily work in your application.

Table 5.1: Common parameters to all the pump control systems

Common parameters to all the pump control systems				
	Name	Default setting	Example's value	User's Value
F02	RUN command	0	1	
F07	Acceleration time 1	20.00 s	3.00 s	
F08	Deceleration time 1	20.00 s	3.00 s	
F11	Electronic Thermal Overload protection. Overload detection Level	100% of the rated motor current	13.0 A	
F12	Electronic Thermal Overload protection. Time constant	5.0 min (22kW or below) 10.0 min (30kW or above)	5 min	
F15	Frequency Limiter. High	70.0 Hz	50.0 Hz	
F16	Frequency Limiter. Low	0.0 Hz	25.0 Hz	
C64	Analog input adjustment for terminal [C1]. Display unit	2: %	4: bar	
C65	Analog input adjustment for terminal [C1]. Max. scale	+ 100.00	Transducer's pressure	
K10	Main monitor display item selection	0: Speed monitor	50: SV	
K16	Sub monitor 1 display item selection	13: Output current	52: MV	
K17	Sub monitor 2 display item selection	19: Input power	51: PV	
E62	Terminal [C1] extended function	0	5	
P01	Motor. Number of poles	4	4	
P02	Motor. Rated Capacity	Rated Capacity standard motor	5.5 kW	
P03	Motor. Rated Current	Rated Current standard motor	13.0 A	
H91	Current input wire break detection	0.0 s	0.5 s	
J101	PID Control 1. Mode Selection	0	1	
J110	PID Control 1. Gain P	0.100	2.500	
J111	PID Control 1. Integral time	0.0 s	0.2 s	
J118	PID Control 1. Upper limit of PID process output	Inherit	50.0 Hz	
J119	PID Control 1. Lower limit of PID process output	Inherit	25.0 Hz	
J149	Slow flow rate stop function. Mode selection	0	1: Manual operation (stop judgement MV)	
J150	Slow flow rate stop function. Sleep frequency	Auto	35.0 Hz	
J151	Slow flow rate stop function. Sleep frequency level latency	0 s	15 s	
J157	Slow flow rate stop function. Wake-up frequency	0 Hz	38.0 Hz	
J158	Slow flow rate stop function. Cancel deviation level 1	OFF	5 %	
J159	Slow flow rate stop function. Cancel delay timer	0 s	1 s	

CONDITIONS TO ACHIEVE GOOD CONTROL IN MULTI-REGULATED PUMP CONTROL WITH 3 REGULATED PUMPS + 1 ADDITIONAL PUMP

Please follow the instructions below if it is necessary to change function codes data:

Conditions for Sleep/Wake-up frequencies

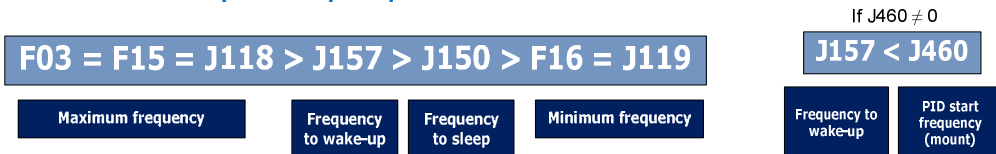

Conditions for the frequencies than define when auxiliary pumps are connected/disconnected

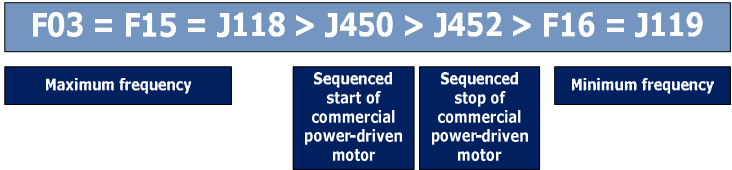

Conditions for the connection of an additional pump



With this topology, it may be necessary to extend the disconnection time of the motor from the commercial power supply (J453), to prevent that the additional and the regulated pumps could be disconnected at the same time. That is, the additional pump must be the first one to be disconnected, and then the regulated pump, but never at the same time.

The following table (Table 5.2) shows the specific parameters for multi-regulated pump control system with 3 regulated pumps + 1 additional pump:

Table 5.2: Specific parameters of multi-regulated pump control with 3 regulated pumps + 1 additional pump

Specific Parameters for multi-regulated pump control with 3 regulated pumps + 1 additional pump				
Name		Default setting	Example's value	User's value
J401	Pump Control. Mode selection	0	2	
J411	Motor 1 mode	0	1	
J412	Motor 2 mode	0	1	
J413	Motor 3 mode	0	1	
J450	Start of commercial power-driven motor. Frequency	999	48 Hz	
J451	Start of commercial power-driven motor. Duration	0.00 s	5.00 s	
J452	Stop of commercial power-driven motor. Frequency	999	30 Hz	
J453	Stop of commercial power-driven motor. Duration	0.00 s	1.00 s	
J459	Motor Unmount switching level	0 %	50 %	
J565	Auxiliary Motor (Frequency operation level)	50.0 Hz	47.0 Hz	
J466	Auxiliary Motor (Hysteresis width)	1.0 Hz	15.0 Hz	
o01	Status Signal Assignment to 6 A/C (OPC-G1-RY2)	6	160 (M1_L)	
o02	Status Signal Assignment to 7 A/C (OPC-G1-RY2)	10	161 (M1_L)	
o03	Status Signal Assignment to 8 A/C (OPC-G1-RY2)	25	162 (M2_L)	
o04	Status Signal Assignment to 9 A/C (OPC-G1-RY2)	26	163 (M2_L)	
o05	Status Signal Assignment to 10 A/C (OPC-G1-RY2)	28	164 (M3_L)	
o06	Status Signal Assignment to 11 A/C (OPC-G1-RY2)	36	165 (M3_L)	
o07	Status Signal Assignment to 12 A/C (OPC-G1-RY2)	37	88 (AUX_L)	

Note: The default setting for function code J460 (0 Hz) may work properly in your installation without adjusting it to the suggested value (39 Hz).

DESCRIPTION OF SPECIFIC PARAMETERS OF MULTI-REGULATED PUMP CONTROL WITH 3 REGULATED PUMPS + 1 ADDITIONAL PUMP

Outputs Set-up

- o07: Status Signal Assignment to 12 A/C (OPC-G1-RY2)

The function code o07 defines the signal assigned to relay output 12 A/C.

In order to implement a multi-regulated pump control system with an additional pump, the 12 A/C terminal's signal must be set to 88, corresponding to AUX_L function.

If all the pumps that are enabled (using parameters J411-J413) have been activated (they are active due to the state of the system), by means of AUX_L function it is possible to activate an extra digital output 12 A/C when the regulated pump's output frequency is higher than the frequency level defined in the function code J565.

In this function, one pump is considered "enabled" when the two conditions below are accomplished at the same time:

- If MEN# is assigned to any digital input, this digital input must be ON (where # is the number of the motor). If MEN# is not assigned to any digital input, this condition will always be true.
- If the parameter, within J411-J413 range, corresponding to this pump is different from zero

In the picture below (Figure 5.3) this function logic block is depicted:

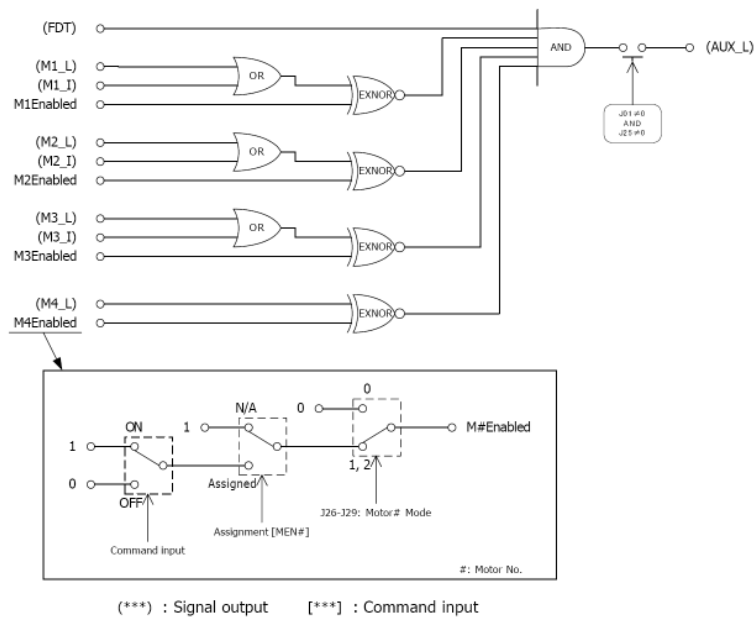

Figure 5.3: Additional pump function logic block diagram

Using function code J466 it is possible to define a hysteresis, for deactivating the pump below certain level of frequency and in order to avoid the signal 12 A/C activating/deactivating constantly.

➤ J565: Auxiliary Motor (Frequency operation level)

This function code defines the detection level where AUX_L function can be activated. That is, if the output frequency is higher than this level, the output with the AUX_L function assigned (88) will be activated. The level configured in J565 must be similar to the value of J450.

➤ J466: Auxiliary Motor (Hysteresis width)

With this parameter it is possible to adjust the hysteresis level for the deactivation of the AUX_L accordingly. The result of J565-J466 must be similar to the value of J452.

Chapter 6

Additional Functions

➤ Dry Pump function (Related function codes -> J176~J180)

Target: to make the inverter enter a STOP state, displaying an error code, when motor torque decreases below a set level for a specified period of time.

Pressure can decrease due to factors such as water leakage or impeller damages. By means of a parameter, an action done by inverter can be selected. The possible actions are stopping or just warning.

Dry pump protection becomes active when all of the conditions (from (1) to (3)) are satisfied and the detection timer (J180) setting time elapses.

- (1) Output frequency detection (Output frequency \geq upper limiter)
(F03, F15, J118, E61 to E63 = 13: lowest frequency among upper limit frequencies)
When pump dries off, output frequency is kept at the upper limiter during operations because the pressure drops.
- (2) Current detection (Output current $<$ J177)
When pump dries off, output current decreases due to the fact that pump load reduces caused by water volume reduction.
- (3) Deviation detection (Feedback value (PV) $<$ PID control command value (SV) – J178)
When pump dries off, feedback values (PV) decreases because air entrance.

In table 6.1, related parameters are shown:

Table 6.1 Specific parameters for Dry Pump function

Specific Parameters Dry pump function				
	Name	Default setting	Example's value	User's value
J176	Dry pump protection. Input selection.	0: Disabled	1: Alarm	
J177	Dry pump protection. Detection current.	OFF: Disabled	Half of motor rated current	
J178	Dry pump protection. Deviation.	0.00: Disabled	10%	
J179	Dry pump protection. Flow sensor.	0: Disabled	0: Disabled	
J180	Dry pump protection. Detection timer.	0	0	

When J176 is set to 1, and J177 and J178 are different than OFF and 0.00 (respectively), after detection current and deviation are reached, inverter will trip by Pdr.

When J176 is set to 1, and any of the other functions is set to 0.00 or OFF, it is considered that this condition is accomplished.

As it can be observed on table 6.1, also a flow sensor can be used to detect Dry Pump. To enable flow sensor set any of the analog inputs (E61 to E63) to 33: flow sensor. Also set in J163 flow sensor units.

For additional information about this function, and how to use a flow sensor refer to User Manual.

➤ Overpressure alarm (related function codes -> J121, J122 and J124)

Target: make the inverter enter a STOP state and display an error code, when the process value (Feedback – pressure transducer) rises above a predefined level.

- **Digital Input to use:** X4 (with “Enable External alarm Trip” command assigned to it)
- **Digital Output to use:** Y2 (with “PID Alarm” signal assigned to it)
- **Wiring:**
 - Connect X4 to Y2
 - Connect CMY to PLC (*)
- **Set-up:**

E04 (X4) = 1009: Enable External Alarm Trip (THR)
 E21 (Y2) = 42: PID Alarm (PID-ALM)
 J122 = PID Control 1. Upper Limit Alarm (AH) (%)
 J124 = PID Control 1. Lower Limit Alarm (AL) (%)

Error Message: when the process value (Feedback – Pressure transducer) is above the value set in J122 (upper limit) or below the value set in J124 (lower limit), the inverter’s output is switched off and the inverter will display *OH2* error code. This error can be reset by means of the VXA keypad or by means of a digital input (8: “Reset Alarm” (RST)).

(*) Assuming that the logic of the digital inputs is Active-High Logic (the common of the inputs is PLC (+24VDC) and inputs’ logic switch is in SOURCE).
 If the common of the inputs is terminal CM (0 VDC) (Active-Low Logic in the inputs), please connect the terminals CMY and CM and set the switch to the SINK position.

Note: In order to select other alarm modes, please see description of function code J121 (PID Control 1. Select Alarm Output) in the User Manual of the **Jaguar-VXA** inverter.

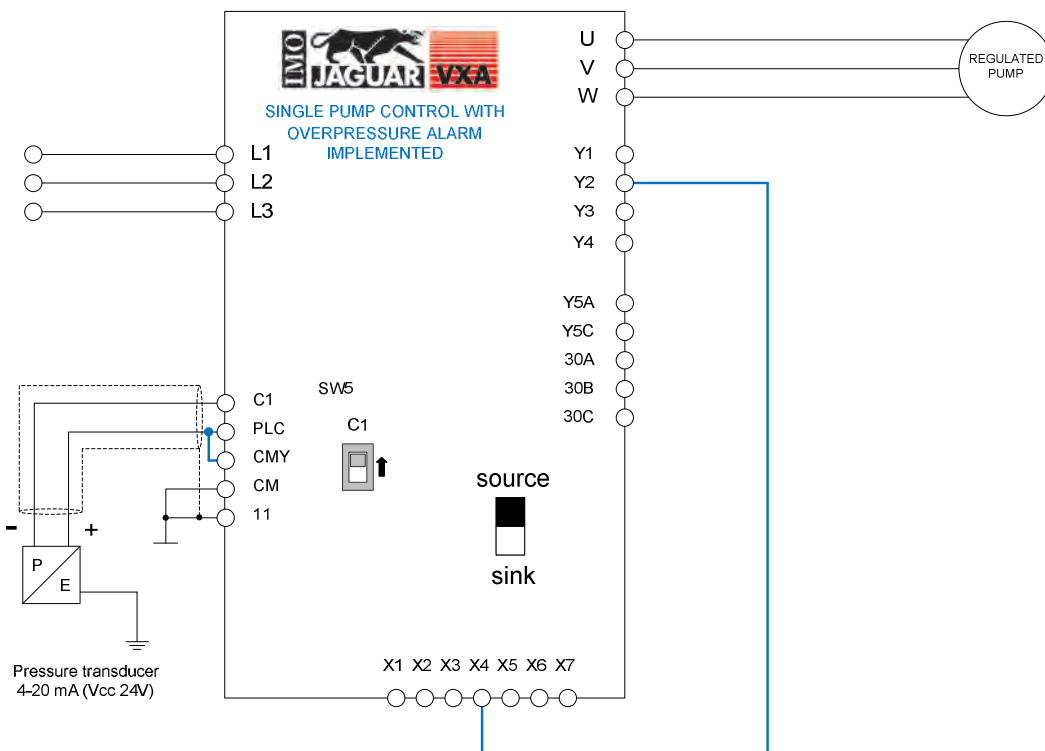

Figure 6.1: Pump control schematic for Overpressure alarm

➤ **PID Display units set-up (related function codes -> C65, C66)**

In order to display the values of PID control (SV, PV, MV, etc.) in engineering units, it is needed the adjustment of the value in C65 according to the sensor range.

Therefore the user will be able to enter the Command (set point) Value in user units (C58, C64 or C70), instead of percentage (of PID range).

For example, if the transducer used has a 4-20 mA output signal range, where 20 mA correspond to 160 bars, the function code C65 must be set to 160.

If the transducer used has a 4-20 mA output signal range, where 20 mA correspond to 10 bars, the function code C65 must be set to 10.

The feedback value, in bars and the process command value can be seen in Menu 6: PID Monitor. Those parameters can be also displayed on keypad main screen. For additional information check k parameters.

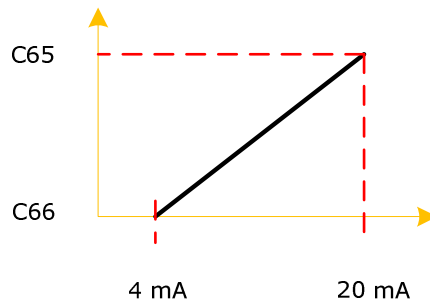

Figure 6.2: PID Display coefficients

➤ **Start-up and switching motors sequence (related function codes -> J425, J436)**

There are two methods to try to extend the pumps' lifetime in Multi-regulated pump control systems

1. Controlling the order of connection of the pumps, by means of the data in function code (*Motor Switching Order*).

J425 = 0	FIXED MOTOR SWITCHING ORDER
The inverter will activate the pumps in ascending order and it will deactivate it in descending order.	
J425 = 1	AUTOMATIC MOTOR SWITCHING ORDER
The inverter will take into account the accumulated working times of each pump. In this way, the first pump to activate is the less used pump, and the first to be disconnected is the more used pump.	
J425 = 2	FIXATION PROCEDURE
The inverter will change the driven pump in ascendant order during slow flow rate (sleeping).	
J425 = 3	EQUAL OPERATING TIME
Same as motor mode 1 but switching also during slow flow rate (sleeping).	

2. The second method is to rotate the pumps.
After the time specified by function code J436 data (*Periodic switching time for motor drive*), the inverter disconnects the pump with major accumulated run time and connects the pump with the minor accumulated run time.

J436 = OFF
The inverter does not switch the pumps (Default setting)
J436 = 0.1 a 720.0 h
The inverter switches the pumps after the time in J436's data (in hours)
J436 = TEST
The inverter switches the pumps every 3 minutes. (Not recommended. Only for tests).

Note: Function codes from J480 to J488 contain the accumulated run time of each pump. These values can be reset (set the time to "0"). It can be useful in case of replacement of an old pump for a newer one.

Using both solutions the pump's working time can be fairly distributed between all the pumps of the system.

➤ [Contactor delay time \(related function code -> J454\)](#)

The function code J454 can be used to make a delay between the stop of a pump and the start-up of another one.

During the time in J454, the inverter's output will be switched off.

This delay can be useful to prevent possible electrically dangerous situations due to an overlapping of the contactors.

➤ [Motor stop mode when "RUN" signal is switched off \(FWD or REV\) \(related function code -> J430\)](#)

The J430 function code establishes the stop mode when "RUN" (FWD or REV) signal is switched off.

J430 = 0

- The regulated pump slows down until it reaches the "Stop Frequency" (F25), decelerating following the F08 function code data.
- The relay that controls the regulated pump is switched **OFF** (in case of multi-regulated pump control).
- The relays that control the non-regulated pumps are switched **OFF** (in any case).
- When an inverter's alarm occurs, all the relays are switched **OFF**.

J430 = 1

- The regulated pump slows down until it reaches the "Stop Frequency" (F25), decelerating following the F08 function code data.
- The relay that controls the regulated pump is switched **OFF** (in case of multi-regulated pump control).
- The relays that control the non-regulated pumps keep in **ON** state (in any case).
- When an inverter's alarm occurs, all the relays are switched **OFF**.

J430 = 2

- The regulated pump slows down until it reaches the "Stop Frequency" (F25), decelerating following the F08 function code data.
- The relay that controls the regulated pump is switched **OFF** (in case of multi-regulated pump control).
- The relays that control the non-regulated pumps keep in **ON** state (in any case).
- When an inverter's alarm occurs, **ONLY** the regulated pump is switched **OFF** (in any case). The relays of the pumps connected to the commercial power supply are kept **ON** (in any case).

➤ [Multiple PID set point selection](#)

Using digital inputs, it is possible to select between four PID set point values.

To perform the multiple selection, functions "2: SS4" and "3: SS8" must be assigned to two digital inputs among X1, X2, X3, X4, X5, X6 or X7 (E01-E07).

The selected Set Value depends of the combination of these two inputs, as shown in the table below:

Table 6.1: Multiple PID set-point selection

SS8	SS4	PID set point selection
0	0	Depends on J02 setting
0	1	C08 (Hz)
1	0	C12 (Hz)
1	1	C16 (Hz)

To calculate the pressure set point from C08, C12 or C16, please use the following equation:

$$C08, C12, C16 = \frac{\text{Desired_pressure}}{\text{Sensor_range}(C59_C65_C71)} \times \text{Maximum_frequency}(F03)$$

➤ [Dead Band \(related function code -> J461\)](#)

Function code J461 can be used to avoid the connection/disconnection (undesired) of any auxiliary pump, when the frequency of the regulated pump is close to the ON/OFF switching frequencies (J459: Motor Unmount switching level, J456: Motor Mount switching level). If the difference between the PID Feedback and PID Set point is less than the percentage stored in J461, the inverter will not make a connection/disconnection of the pump.

➤ Dew condensation prevention function(related function codes -> F21, F22, J21)

By means of a DC current injection, it's possible to keep the motor warm to prevent condensation. Please note a digital input should be activated to enable this function (for instance X4, by using function code E04).

Example

E04 = 39: Protect motor from dew condensation (DWP)
F21 = 10 %
F22 = 1 s (T ON)
J21 = 1 % (DUTY CYCLE)

With this adjustment, there will be a DC current injection every 100 seconds, equivalent to the 10% of the rated current, during 1 second.

$$J21(\%) = \frac{F22}{T} \times 100 \quad \text{In this example:} \quad T = \frac{F22}{J21} \times 100 = \frac{1}{1} \times 100 = 100s ;$$

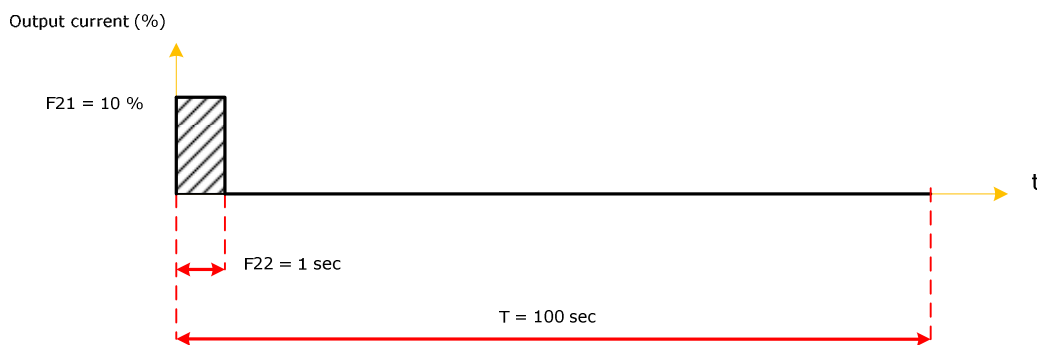

Figure 6.3: Output current when Dew Condensation prevention function is enabled

➤ PID Integral component hold

1. Holding PID integral component while pump is in sleep mode

Target: Make the inverter maintain (hold) the PID controller integral component once the regulated pump has gone to sleep.

The main purpose is to avoid overshooting when the pump wakes up.

Applicable when: The installation has a lot of leakage.

Explanation: The pump provides pressure to the installation, and when the pressure command level is reached, if there is no consumption, the inverter will bring the pump to sleep.

Due to the leakages/losses, the pressure will decrease and the inverter will start up the pump again in order to reach the set point value. This cycle can be repeated until real flow consumption appears.

In old installations, this sleep/wake-up cycle is repeated continuously.

If you want to make this repetition slower (to make longer the time between sleep and wake-up), the functions codes J158 and J159 can be useful (two additional conditions to wake up the regulated pump are added).

Normally, by means of using these function codes, it is possible to separate the sleep and wake-up events. The idea is to increase J158 (% of error) until the time between sleep and wake-up is long enough.

But, what happens if the value in J158 is too high?

...of course, the pump's wake-up will be delayed enough, but the accumulated process error will cause a bigger integral action, producing a pressure overshoot when the regulated pump wakes up. The pressure overshoot varies depending on each application, and it can be higher than expected. In addition, it depends also on the values in J158 and J159 and PID gains (J110, J111 and J112). In order to avoid the overshoot, holding the integral while the pumps sleep can be useful (avoiding the error integration)

- Digital Inputs: X4 (set to hold integral action function)
- Digital Outputs: Y2 (set to "Motor stopping due to slow flow rate under PID control" function)
- Wiring:
 - Bridge X4 and Y2
 - Bridge CMY and PLC (*)
- Set-up:
 - E04 (X4) = 34: Hold PID integral component (PID-HLD)
 - E21 (Y2) = 44: Motor stopping due to slow flowrate under PID control (PID-STP)
 - J158 = 20%

(*) Assuming that the logic of the digital inputs is Active-High Logic (the common of the inputs is PLC (+24VDC) and inputs' logic switch is in SOURCE). If the common of the inputs is terminal CM (0 VDC) (Active-Low Logic in the inputs), please connect the terminals CMY and CM and set the switch to the SINK position.

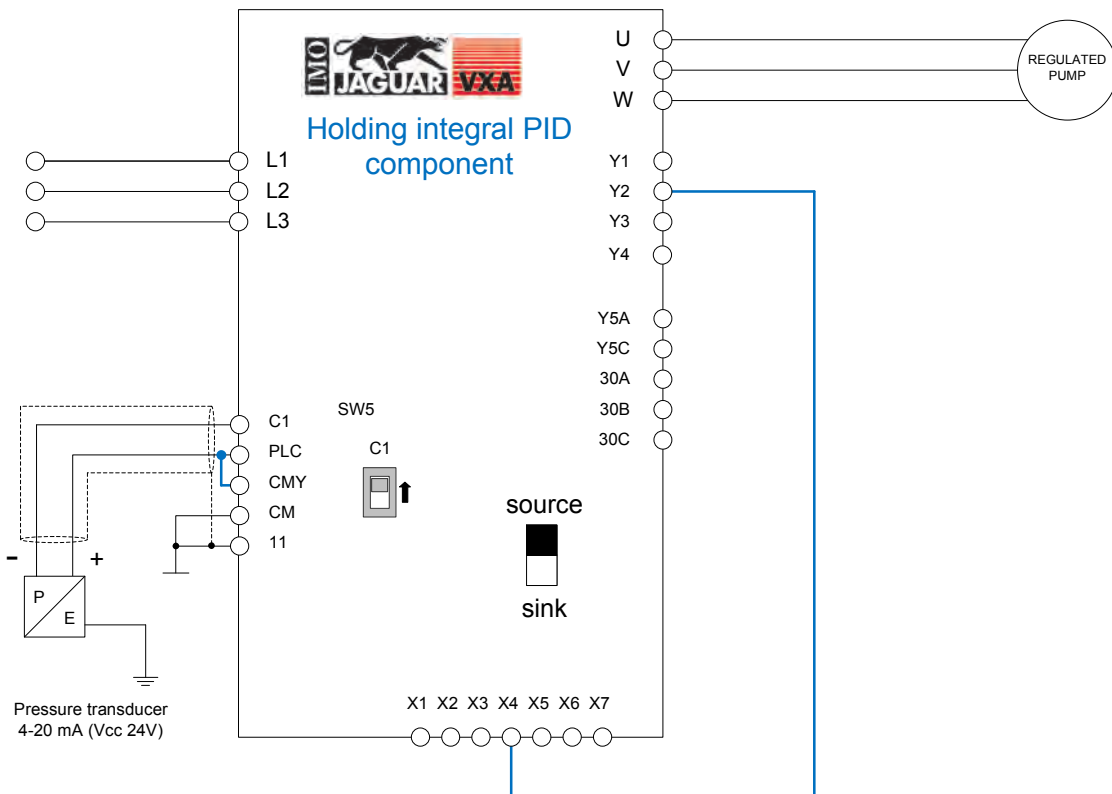

Figure 6.4: Pump control schematic for holding PID Integral component when pump is in sleep mode

2. Holding integral PID component during the process (anti-reset wind-up)

J114 function code can be used to hold the integral PID component.

The integral component will be active only when the difference (error) between process value (PV) and set point (SV) is inside the limits defined by J114 function code. If bigger than these limits, current integral PID component will be held.

J114 is a percentage related with C65 function code.

For instance, if the transducer installed is 10 bar (C65 = 10) and J114 is set at 10%, integral PID component will be active when the error of the system (error = SV-PV) is less than 1 bar (for errors larger than 1 bar integral PID component will be held at its current value).

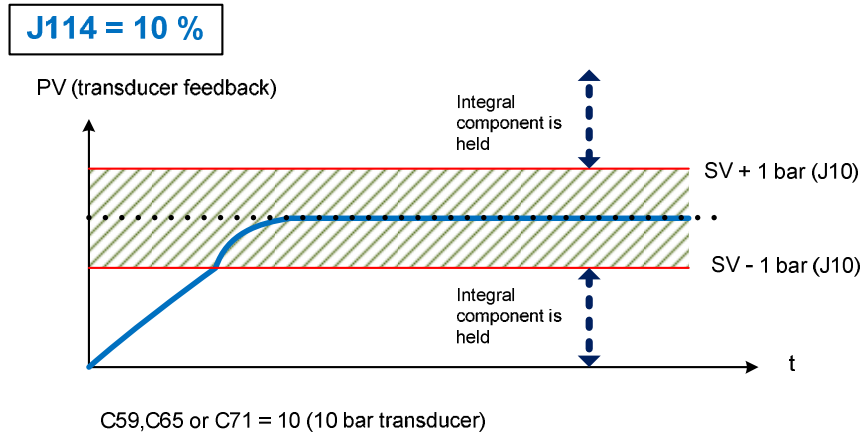

Figure 6.5: PID behaviour when function J114 is used.

➤ Enable / Disable pumps by means of external selectors

It's possible to enable/disable pumps by means of external selection.

A pump can be disabled in order to prevent its operation in the pump control system. This function is useful when performing pump maintenance or other reasons.

151 (1151): Enable pump drive (motor 1)	(MEN1)
152 (1152): Enable pump drive (motor 2)	(MEN2)
153 (1153): Enable pump drive (motor 3)	(MEN3)
154 (1154): Enable pump drive (motor 4)	(MEN4)
155 (1155): Enable pump drive (motor 5)	(MEN5)
156 (1156): Enable pump drive (motor 6)	(MEN6)
157 (1157): Enable pump drive (motor 7)	(MEN7)
158 (1158): Enable pump drive (motor 8)	(MEN8)

- Digital Inputs: for example X4 (set to Enable pump drive function).
- Wiring:
 - Bridge X4 and PLC (*)
- Set-up:

E04 (X4) = 151: Enable pump drive (motor 1) (MEN1)

(*) Assuming that the logic of the digital inputs is Active-High Logic (the common of the inputs is PLC (+24VDC) and inputs' logic switch is in SOURCE).

If the common of the inputs is terminal CM (0 VDC) (Active-Low Logic in the inputs), please connect the terminals CMY and CM and set the switch to the SINK position.

Chapter 7

Complete Function Codes' List

*Only function codes' related with this Pump Control Quick Guide are shown. For more details about other functions, please check User Manual.

F codes: Fundamental Functions

Code	Name	Data setting range	Change when running	Data copying	Default setting
F00	Data Protection	0: Disable both data protection and digital reference protection 1: Enable data protection and disable digital reference protection 2: Disable data protection and enable digital reference protection 3: Enable both data protection and digital reference protection	Y	Y	0
F01	Frequency Command 1	0: / / / keys on keypad 1: Voltage input to terminal [12] (-10 to +10 VDC) 2: Current input to terminal [C1] (4 to 20 mA DC) 3: Sum of voltage and current inputs to terminals [12] and [C1] 5: Voltage input to terminal [V2] (0 to 10 VDC) 7: Terminal command UP/DOWN control 8: / / / keys on keypad (balanceless-bumpless switching available) 10: Pattern operation	N	Y	0
F02	Operation Method	0: FWD/REV/STOP keys on keypad (Motor rotational direction specified by terminal command FWD/REV) 1: External signals (Terminal command FWD or REV) 2: FWD/STOP keys on keypad (forward) 3: REV/STOP keys on keypad (reverse)	N	Y	0
F03	Maximum Frequency 1	25.0 to 120.0 Hz	N	Y	50.0
F04	Base Frequency 1	25.0 to 120.0 Hz	N	Y	50.0
F05	Rated Voltage at Base Frequency 1	0: Output a voltage in proportion to input voltage 160 to 500 V: Output an AVR-controlled voltage	N	Y	400
F06	Maximum Output Voltage 1	160 to 500 V: Output an AVR-controlled voltage	N	Y	
F07	Acceleration Time 1	0.00 to 3600.00 s	Y	Y	20.00
F08	Deceleration Time 1	Note: Entering 0.00 cancels the acceleration time, requiring external soft-start.	Y	Y	20.00
F09	Torque Boost 1	0.0% to 20.0% (percentage with respect to "F05: Rated Voltage at Base Frequency 1")	Y	Y	*1
F10	Electronic Thermal Overload Protection for Motor 1 (Select motor characteristics)	1: For a general-purpose motor with shaft-driven cooling fan 2: For an inverter-driven motor, non-ventilated motor, or motor with separately powered cooling fan	Y	Y	1
F11	(Overload detection level)	OFF: Disable 1% to 135% of the inverter rated current	Y	Y1	*3
F12	(Thermal time constant)	0.5 to 75.0 min	Y	Y	*2
F14	Restart Mode after Momentary Power Failure (Mode selection)	0: Trip immediately 1: Trip after a recovery from power failure 3: Continue to run, for heavy inertia or general loads 4: Restart at the frequency at which the power failure occurred, for general loads 5: Restart at the starting frequency	Y	Y	0
F15	Frequency Limiter (High)	0.0 to 120.0 Hz	Y	Y	70.0
F16	(Low)	0.0 to 120.0 Hz	Y	Y	0.0
F18	Bias (Frequency command 1)	-100.00% to 100.00%	Y*	Y	0.00
F20	DC Braking 1 (Braking starting frequency)	0.0 to 60.0 Hz	Y	Y	0.0
F21	(Braking level)	0% to 60% on the basis of inverter rated current	Y	Y	0
F22	(Braking time)	OFF (Disable); 0.01 to 30.00 s	Y	Y	OFF
F23	Starting Frequency 1	0.1 to 60.0 Hz	Y	Y	0.5
F24	(Holding time)	0.00 to 10.00 s	Y	Y	0.00
F25	Stop Frequency	0.1 to 60.0 Hz	Y	Y	0.2
F26	Motor Sound (Carrier frequency)	0.75 to 16 kHz (0.75 to 37 kW) 0.75 to 10 kHz (45 to 90 kW) 0.75 to 6 kHz (110 to 630 kW) 0.75 to 4 kHz (710 kW)	Y	Y	2
F27	(Tone)	0: Level 0 (Inactive) 1: Level 1 2: Level 2 3: Level 3	Y	Y	0
F29	Analog Output [FM1] (Mode selection)	0: Output in voltage (0 to 10 VDC) 1: Output in current (4 to 20 mA DC) 2: Output in current (0 to 20 mA DC)	Y	Y	0
F30	(Voltage adjustment)	0% to 300%	Y*	Y	100

The shaded function codes () are applicable to the quick setup.

*1 The factory default differs depending upon the inverter's capacity. See Table A.

*2 5.0 min for inverters with a capacity of 22 kW or below; 10.0 min for those with 30 kW or above

*3 The motor rated current is automatically set. See Table B (function code P03).

Code	Name		Data setting range	Change when running	Data copying	Default setting
F31	Analog Output [FM1]	(Function)	Select a function to be monitored from the followings: 0: Output frequency 1 (before slip compensation) 1: Output frequency 2 (after slip compensation) 2: Output current 3: Output voltage 4: Output torque 5: Load factor 6: Input power 7: PID feedback amount 9: DC link bus voltage 10: Universal AO (Note 1) 13: Motor output 14: Calibration (+) (Note 1) 15: PID command (SV) 16: PID output (MV) 18: Heat sink temperature (200°C/10 V) 20: Reference frequency 50: PID feedback amount 1 (PV1) 51: PID command 1 (SV1) 52: PID control 1 deviation (ERR1) (Note 2) 53: PID control final deviation (ERR) (Note 2) 54: PID feedback amount 2 (PV2) 55: PID command 2 (SV2) 56: PID control 2 deviation (ERR2) (Note 2) 60: External PID feedback amount 1 (EPID1-PV) 61: External PID command 1 (EPID1-SV) 62: External PID control 1 deviation (EPID1-ERR) (Note 2) 63: External PID control 1 final deviation (EPID1-ERR) (Note 2) 65: External PID final output 1 (EPID1-OUT) 70: External PID feedback amount 2 (EPID2-PV) 71: External PID command 2 (EPID2-SV) 72: External PID control 2 deviation (EPID2-ERR) (Note 2) 75: External PID final output 2 (EPID2-OUT) 80: External PID feedback amount 3 (EPID3-PV) 81: External PID command 3 (EPID3-SV) 82: External PID control 3 deviation (EPID3-ERR) (Note 2) 85: External PID final output 3 (EPID3-OUT) 111: Customizable logic output signal 1 (Note 1) 112: Customizable logic output signal 2 (Note 1) 113: Customizable logic output signal 3 (Note 1) 114: Customizable logic output signal 4 (Note 1) 115: Customizable logic output signal 5 (Note 1) 116: Customizable logic output signal 6 (Note 1) 117: Customizable logic output signal 7 (Note 1) (Note 1) Cannot be selected with U02, U03, etc. (Note 2) Deviation output is supported only by option terminal [Ao] (o09).	Y	Y	0
F32	Pulse Output [FM2]	(Mode selection)	0: Voltage (0 to +10 VDC) 1: Current (4 to +20 mA DC) 2: Current (0 to +20 mA DC)	Y	Y	0
F34		(Voltage adjustment)	0 to 300%	Y	Y	0
F35		(Function)	Same as F31.	Y	Y	0
F37	Load Selection/ Auto Torque Boost/ Auto Energy Saving Operation 1		0: Variable torque load 1: Constant torque load 2: Auto torque boost 3: Auto energy saving (Variable torque load during ACC/DEC) 4: Auto energy saving (Constant torque load during ACC/DEC) 5: Auto energy saving (Auto torque boost during ACC/DEC)	N	Y	1
F40	Torque Limiter 1	(Driving)	OFF: Disable	Y	Y	OFF
F41		(Braking)	20% to 150%: Torque limiter level			
F42	Drive Control Selection 1		0: V/f control with slip compensation inactive 1: Dynamic torque vector control 2: V/f control with slip compensation active	M	Y	0
F43	Current Limiter	(Mode selection)	0: Disable (No current limiter works.) 1: Enable at constant speed (Disable during ACC/DEC) 2: Enable during ACC/constant speed operation	Y	Y	2
F44		(Level)	20% to 120% (Assuming the inverter rated current as 100%.)	Y	Y	120

E codes: Extension Terminal Functions

Code	Name	Data setting range	Change when running	Data copying	Default setting
E01	Terminal [X1] Function	Selecting function code data assigns the corresponding function to terminals [X1] to [X7] as listed below.	N	Y	0
E02	Terminal [X2] Function	0 (1000): Select multistep frequency (0 to 1 steps) (SS1)	N	Y	1
E03	Terminal [X3] Function	1 (1001): Select multistep frequency (0 to 3 steps) (SS2)	N	Y	6
E04	Terminal [X4] Function	2 (1002): Select multistep frequency (0 to 7 steps) (SS4)	N	Y	7
E05	Terminal [X5] Function	3 (1003): Select multistep frequency (0 to 15 steps) (SS8)	N	Y	8
E06	Terminal [X6] Function	4 (1004): Select ACC/DEC time (2 steps) (RT1)	N	Y	11
E07	Terminal [X7] Function	5 (1005): Select ACC/DEC time (4 steps) (RT2)	N	Y	35
		6 (1006): Enable 3-wire operation (HLD)			
		7 (1007): Coast to a stop (BX)			
		8 (1008): Reset alarm (RST)			
		9 (1009): Enable external alarm trip (9 = Active OFF, 1009 = Active ON) (THR)			
		11 (1011): Select frequency command 2/1 (Hz2/Hz1)			
		13: Enable DC braking (DCBRK)			
		14 (1014): Select torque limiter level 2/1 (TL2/TL1)			
		15: Switch to commercial power (50 Hz) (SW50)			
		16: Switch to commercial power (60 Hz) (SW60)			
		17 (1017): UP (Increase output frequency) (UP)			
		18 (1018): DOWN (Decrease output frequency) (DOWN)			
		19 (1019): Enable data change with keypad (WE-KP)			
		20 (1020): Cancel PID control (Hz/PID)			
		21 (1021): Switch normal/inverse operation (IVS)			
		22 (1022): Interlock (IL)			
		24 (1024): Enable communications link via RS-485 or fieldbus (option) (LE)			
		25 (1025): Universal DI (U-DI)			
		26 (1026): Enable auto search for idling motor speed at starting (STM)			
		30 (1030): Force to stop (30 = Active OFF, 1030 = Active ON) (STOP)			
		33 (1033): Reset PID integral and differential components (PID-RST)			
		34 (1034): Hold PID integral component (PID-HLD)			
		35 (1035): Select local (keypad) operation (LOC)			
		38 (1038): Enable run commands (RE)			
		39: Protect motor from dew condensation (DWP)			
		40: Enable integrated sequence to switch to commercial power (50 Hz) (ISW50)			
		41: Enable integrated sequence to switch to commercial power (60 Hz) (ISW60)			
		50 (1050): Clear running motor regular switching time (MCLR)			
		58 (1058): Reset UP/DOWN frequency (STZ)			
		72 (1072): Count the run time of commercial power-driven motor 1 (CRUN-M1)			
		80 (1080): Cancel customizable logic (CLC)			
		81 (1081): Clear all customizable logic timers (CLTC)			
		87 (1087): Run command 2/1 (FR2/FR1)			
		88: Run forward 2 (FWD2)			
		89: Run reverse 2 (REV2)			
		100: No function assigned (NONE)			
		130 (1130): Boost command (BST)			
		131 (1131): Flowrate switch (FS)			
		132 (1132): Filter clogging reverse rotation command (FRC)			
		133 (1133): Switch PID channel (PID2/1)			
		134: Switch to fire mode (FMS)			
		149 (1149): Switch pump control (PCHG)			
		150 (1150): Enable master motor drive in mutual operation (MENO)			
		151 (1151): Enable pump control motor 1 to be driven (MEN1)			
		152 (1152): Enable pump control motor 2 to be driven (MEN2)			
		153 (1153): Enable pump control motor 3 to be driven (MEN3)			
		154 (1154): Enable pump control motor 4 to be driven (MEN4)			
		155 (1155): Enable pump control motor 5 to be driven (MEN5)			
		156 (1156): Enable pump control motor 6 to be driven (MEN6)			
		157 (1157): Enable pump control motor 7 to be driven (MEN7)			
		158 (1158): Enable pump control motor 8 to be driven (MEN8)			
		171 (1171): PID multistep command (PID-SS1)			
		172 (1172): PID multistep command (PID-SS2)			
		181 (1181): External PID multistep command (EPID-SS1)			
		182 (1182): External PID multistep command (EPID-SS2)			

Code	Name	Data setting range	Change when running	Data copying	Default setting
		190 (1190): Cancel timer (TMC) 191 (1191): Enable timer 1 (TM1) 192 (1192): Enable timer 2 (TM2) 193 (1193): Enable timer 3 (TM3) 194 (1194): Enable timer 4 (TM4) 201 (1201): External PID control 1 ON command (EPID1-ON) 202 (1202): Cancel external PID control 1 (%EPID1) 203 (1203): Switch normal/inverse operation under external PID control 1 (EPID1-IVS) 204 (1204): Reset external PID1 integral and differential components (EPID1-RST) 205 (1205): Hold external PID1 integral component (EPID1-HLD) 211 (1211): External PID control 2 ON command (EPID2-ON) 212 (1212): Cancel external PID control 2 (%EPID2) 213 (1213): Switch normal/inverse operation under external PID control 2 (EPID2-IVS) 214 (1214): Reset external PID2 integral and differential components (EPID2-RST) 215 (1215): Hold external PID2 integral component (EPID2-HLD) 221 (1221): External PID control 3 ON command (EPID3-ON) 222 (1222): Cancel external PID control 3 (%EPID3) 223 (1223): Switch normal/inverse operation under external PID control 3 (EPID3-IVS) 224 (1224): Reset external PID3 integral and differential components (EPID3-RST) 225 (1225): Hold external PID3 integral component (EPID3-HLD) Setting the value in parentheses () shown above assigns a negative logic output to a terminal. (True if OFF.) Setting the value of 1000s in parentheses () shown above assigns a negative logic input to a terminal.			
E10	Acceleration Time 2	0.00 to 3600.00 s	Y	Y	20.00
E11	Deceleration Time 2	Note: Entering 0.00 cancels the acceleration time, requiring external soft-start and -stop.	Y	Y	20.00
E12	Acceleration Time 3		Y	Y	20.00
E13	Deceleration Time 3		Y	Y	20.00
E14	Acceleration Time 4		Y	Y	20.00
E15	Deceleration Time 4		Y	Y	20.00
E16	Torque Limiter 2 (Driving)	OFF: Disable	Y	Y	OFF
E17	(Braking)	20% to 150%: Torque limiter level	Y	Y	OFF
E20	Terminal [Y1] Function	Selecting function code data assigns the corresponding function to terminals [Y1] to [Y5A/C] and [30A/B/C] as listed below.	N	Y	0
E21	Terminal [Y2] Function	0 (1000): Inverter running (RUN)	N	Y	1
E22	Terminal [Y3] Function	1 (1001): Frequency (speed) arrival signal (FAR)	N	Y	2
E23	Terminal [Y4] Function	2 (1002): Frequency (speed) detected (FDT)	N	Y	7
E24	Terminal [Y5A/C] Function	3 (1003): Undervoltage detected (inverter stopped) (LV)	N	Y	15
E27	Terminal [30A/B/C] Function (Relay output)	5 (1005): Inverter output limiting (IOL)	N	Y	99
		6 (1006): Auto-restarting after momentary power failure (IPF)			
		7 (1007): Motor overload early warning (OL)			
		10 (1010): Inverter ready to run (RDY)			
		11: Switch motor drive source between commercial power and inverter output (For MC on commercial line) (SW88)			
		12: Switch motor drive source between commercial power and inverter output (For secondary side) (SW52-2)			
		13: Switch motor drive source between commercial power and inverter output (For primary side) (SW52-1)			
		15 (1015): Select AX terminal function (For MC on primary side) (AX)			
		16 (1016): Shifted to pattern operation stage (TU)			
		17 (1017): Pattern operation cycle completed (TO)			
		18 (1018): Pattern operation stage number (STG1)			
		19 (1019): Pattern operation stage number (STG2)			
		20 (1020): Pattern operation stage number (STG4)			
		22 (1022): Inverter output limiting with delay (IOL2)			
		25 (1025): Cooling fan in operation (FAN)			
		26 (1026): Auto-resetting (TRY)			
		27 (1027): Universal DO (U-DO)			
		28 (1028): Heat sink overheat early warning (OH)			
		30 (1030): Lifetime alarm (LIFE)			
		31 (1031): Frequency (speed) detected 2 (FDT2)			
		33 (1033): Reference loss detected (REF OFF)			
		35 (1035): Inverter output on (RUN2)			
		36 (1036): Overload prevention control (OLP)			
		37 (1037): Current detected (ID)			
		42 (1042): PID alarm (PID-ALM)			
		43 (1043): Under PID control (PID-CTL)			

Code	Name	Data setting range	Change when running	Data copying	Default setting
44 (1044):	Motor stopped due to slow flowrate under PID control	(PID-STP)			
45 (1045):	Low output torque detected	(U-TL)			
52 (1052):	Running forward	(FRUN)			
53 (1053):	Running reverse	(RRUN)			
54 (1054):	In remote operation	(RMT)			
55 (1055):	Run command entered	(AX2)			
56 (1056):	Motor overheat detected by thermistor	(THM)			
59 (1059):	Terminal [C1] wire break	(C1OFF)			
68 (1068):	Motor regular switching early warning	(MCHG)			
69 (1069):	Pump control output limit signal	(MLIM)			
84 (1084):	Maintenance timer	(MNT)			
87(1087):	Frequency arrival signal	(FARFDT)			
88(1088):	Auxiliary motor drive signal	(AUX_L)			
95(1095):	Running in fire mode	(FMRUN)			
98 (1098):	Light alarm	(L-ALM)			
99 (1099):	Alarm output (for any alarm)	(ALM)			
101(1101):	EN terminal detection circuit error	(DECF)			
102(1102):	EN terminal OFF	(ENOFF)			
111 (1111):	Customizable logic output signal 1	(CLO1)			
112 (1112):	Customizable logic output signal 2	(CLO2)			
113 (1113):	Customizable logic output signal 3	(CLO3)			
114 (1114):	Customizable logic output signal 4	(CLO4)			
115 (1115):	Customizable logic output signal 5	(CLO5)			
116 (1116):	Customizable logic output signal 6	(CLO6)			
117 (1117):	Customizable logic output signal 7	(CLO7)			
160 (1160):	Motor 1 being driven by inverter	(M1_I)			
161 (1161):	Motor 1 being driven by commercial power	(M1_L)			
162 (1162):	Motor 2 being driven by inverter	(M2_I)			
163 (1163):	Motor 2 being driven by commercial power	(M2_L)			
164 (1164):	Motor 3 being driven by inverter	(M3_I)			
165 (1165):	Motor 3 being driven by commercial power	(M3_L)			
166 (1166):	Motor 4 being driven by inverter	(M4_I)			
167 (1167):	Motor 4 being driven by commercial power	(M4_L)			
169 (1169):	Motor 5 being driven by commercial power	(M5_L)			
171 (1171):	Motor 6 being driven by commercial power	(M6_L)			
173 (1173):	Motor 7 being driven by commercial power	(M7_L)			
175 (1175):	Motor 8 being driven by commercial power	(M8_L)			
180 (1180):	In mutual operation	(M-RUN)			
181 (1181):	Alarm in mutual operation	(M-ALM)			
190 (1190):	In timer operation	(TMD)			
191 (1191):	Timer 1 enabled	(TMD1)			
192 (1192):	Timer 2 enabled	(TMD2)			
193 (1193):	Timer 3 enabled	(TMD3)			
194 (1194):	Timer 4 enabled	(TMD4)			
200 (1200):	Under PID2 control	(PID2)			
201 (1201):	PID1 alarm	(PV1-ALM)			
202 (1202):	PID1 feedback error	(PV1-OFF)			
203 (1203):	PID2 alarm	(PV2-ALM)			
204 (1204):	PID2 feedback error	(PV2-OFF)			
211 (1211):	Under external PID1 control	(EPID1-CTL)			
212 (1212):	External PID1 output	(EPID1-OUT)			
213 (1213):	Running under external PID1	(EPID1-RUN)			
214 (1214):	External PID1 alarm	(EPV1-ALM)			
215 (1215):	External PID1 feedback error	(EPV1-OFF)			
221 (1221):	Under external PID2 control	(EPID2-CTL)			
222 (1222):	External PID2 output	(EPID2-OUT)			
223 (1223):	Running under external PID2	(EPID2-RUN)			
224 (1224):	External PID2 alarm	(EPV2-ALM)			
225 (1225):	External PID2 feedback error	(EPV2-OFF)			
231 (1231):	Under external PID3 control	(EPID3-CTL)			
232 (1232):	External PID3 output	(EPID3-OUT)			
233 (1233):	Running under external PID3	(EPID3-RUN)			
234 (1234):	External PID3 alarm	(EPV3-ALM)			
235 (1235):	External PID3 feedback error	(EPV3-OFF)			
Setting the value in parentheses () shown above assigns a negative logic output to a terminal. (True if OFF)					
Setting the value of 1000s in parentheses () shown above assigns a negative logic input to a terminal.					

Code	Name	Data setting range	Change when running	Data copying	Default setting
E30	Frequency Arrival (Hysteresis width)	0.0 to 10.0 Hz	Y	Y	2.5
E31	Frequency Detection 1 (Level)	0.0 to 120.0 Hz	Y	Y	50.0
E32	(Hysteresis width)	0.0 to 120.0 Hz	Y	Y	1.0
E34	Overload Early Warning/Current Detection (Level)	OFF: Disable 1 to 150% of inverter rated current	Y	Y1	*3
E35	(Timer)	0.01 to 600.00s	Y	Y	10.00
E61	Terminal [I2] Extended Function	0: None	N	Y	0
E62	Terminal [C1] Extended Function	1: Auxiliary frequency command 1	N	Y	0
E63	Terminal [V2] Extended function	2: Auxiliary frequency command 2 3: PID process command 1 4: PID process command 2 5: PID feedback value 1 12: Acceleration/deceleration time ratio setting 13: Upper limit frequency 14: Lower limit frequency 20: Analog signal input monitor 30: PID feedback value 2 31: Auxiliary input 1 to PID process command 32: Auxiliary input 2 to PID process command 33: Flow sensor 41: External PID process command 1 42: External PID feedback value 1 43: External PID manual command 1 44: External PID process command 2 45: External PID feedback value 2 46: External PID manual command 2 47: External PID process command 3 48: External PID feedback value 3 49: External PID manual command 3	N	Y	0
E64	Saving of Digital Reference Frequency	0: Automatic saving (when main power is turned OFF) 1: Saving by pressing (F) key	Y	Y	1
E65	Reference Loss Detection (Continuous running frequency)	OFF: Cancel Decel: Decelerate to stop 20% to 120%	Y	Y	OFF
E80	Low Torque Detection (Level)	0% to 150%	Y	Y	20
E81	(Timer)	0.01 to 600.00 s	Y	Y	20.00
E82	Switching Frequency of Accel/Decel Time in Low-Speed Domain	Inherit: Follow the setting of F16 0.1 to 120.0 Hz	Y	Y	Inherit
E83	Acceleration Time in Low-Speed Domain	Inherit: Follow the current acceleration time 0.01 to 3600.00 s; Acceleration time from 0 Hz to E82	Y	Y	Inherit
E84	Deceleration Time in Low-Speed Domain	Inherit: Follow the current deceleration time 0.01 to 3600.00 s; Deceleration time from E82 to 0 Hz	Y	Y	Inherit
E85	Gradual Deceleration Time Switching Frequency	OFF: Disable 0.1 to 120.0 Hz	Y	Y	OFF
E86	Gradual Deceleration Time (Check valve protection)	Inherit: Follow the current deceleration time 0.01 to 3600.00 s; Deceleration time from E82 to E85	Y	Y	Inherit

*3 The motor rated current is automatically set. See Table B (function code P03).

Code	Name	Data setting range	Change when running	Data copying	Default setting
		Selecting function code data assigns the corresponding function to terminals [FWD] and [REV] as listed below.			
E98	Terminal [FWD] Function	0 (1000): Select multistep frequency (0 to 1 steps) (SS1)	N	Y	98
E99	Terminal [REV] Function	1 (1001): Select multistep frequency (0 to 3 steps) (SS2)	N	Y	99
		2 (1002): Select multistep frequency (0 to 7 steps) (SS4)			
		3 (1003): Select multistep frequency (0 to 15 steps) (SS8)			
		4 (1004): Select ACC/DEC time (2 steps) (RT1)			
		5 (1005): Select ACC/DEC time (4 steps) (RT2)			
		6 (1006): Enable 3-wire operation (HLD)			
		7 (1007): Coast to a stop (BX)			
		8 (1008): Reset alarm (RST)			
		9 (1009): Enable external alarm trip (9 = Active OFF, 1009 = Active ON) (THR)			
		11 (1011): Select frequency command 2/1 (Hz2/Hz1)			
		13: Enable DC braking (DCBRK)			
		14 (1014): Select torque limiter level 2/1 (TL2/TL1)			
		15: Switch to commercial power (50 Hz) (SW50)			
		16: Switch to commercial power (60 Hz) (SW60)			
		17 (1017): UP (Increase output frequency) (UP)			
		18 (1018): DOWN (Decrease output frequency) (DOWN)			
		19 (1019): Enable data change with keypad (WE-KP)			
		20 (1020): Cancel PID control (Hz/PID)			
		21 (1021): Switch normal/inverse operation (IVS)			
		22 (1022): Interlock (IL)			
		24 (1024): Enable communications link via RS-485 or fieldbus (LE)			
		25 (1025): Universal DI (U-DI)			
		26 (1026): Enable auto search for idling motor speed at starting (STM)			
		30 (1030): Force to stop (30 = Active OFF, 1030 = Active ON) (STOP)			
		33 (1033): Reset PID integral and differential components (PID-RST)			
		34 (1034): Hold PID integral component (PID-HLD)			
		35 (1035): Select local (keypad) operation (LOC)			
		38 (1038): Enable run commands (RE)			
		39: Protect motor from dew condensation (DWP)			
		40: Enable integrated sequence to switch to commercial power (50 Hz) (ISW50)			
		41: Enable integrated sequence to switch to commercial power (60 Hz) (ISW60)			
		50 (1050): Clear running motor regular switching time (MCLR)			
		58 (1058): Reset UP/DOWN frequency (STZ)			
		72 (1072): Count the run time of commercial power-driven motor 1 (CRUN-M1)			
		80 (1080): Cancel customizable logic (CLC)			
		81 (1081): Clear all customizable logic timers (CLTC)			
		87 (1087): Run command 2/1 (FR2/FR1)			
		88: Run forward 2 (FWD2)			
		89: Run reverse 2 (REV2)			
		98: Run forward (FWD)			
		99: Run reverse (REV)			
		100: No function assigned (NONE)			
		130 (1130): Boost command (BST)			
		131 (1131): Flowrate switch (FS)			
		132 (1132): Filter clogging reverse rotation command (FRC)			
		133 (1133): Switch PID channel (PID2/1)			
		134: Switch to fire mode (FMS)			
		148 (1148): Switch pump control (PCHG)			
		150 (1150): Enable master motor drive in mutual operation (MENO)			
		151 (1151): Pump control motor 1 (MEN1)			
		152 (1152): Pump control motor 2 (MEN2)			
		153 (1153): Pump control motor 3 (MEN3)			
		154 (1154): Pump control motor 4 (MEN4)			
		155 (1155): Pump control motor 5 (MEN5)			
		156 (1156): Pump control motor 6 (MEN6)			
		157 (1157): Pump control motor 7 (MEN7)			
		158 (1158): Pump control motor 8 (MEN8)			
		171 (1171): PID multistep command (PID-SS1)			
		172 (1172): PID multistep command (PID-SS2)			
		181 (1181): External PID multistep command (EPID-SS1)			
		182 (1182): External PID multistep command (EPID-SS2)			

Code	Name	Data setting range	Change when running	Data copying	Default setting
		190 (1190): Cancel timer (TMC)			
		191 (1191): Enable timer 1 (TM1)			
		192 (1192): Enable timer 2 (TM2)			
		193 (1193): Enable timer 3 (TM3)			
		194 (1194): Enable timer 4 (TM4)			
		201 (1201): External PID control 1 ON command (EPID1-ON)			
		202 (1202): Cancel external PID control 1 (%/EPID1)			
		203 (1203): Switch normal/inverse operation under external PID control 1 (EPID1-IVS)			
		204 (1204): Reset external PID1 integral and differential components (EPID1-RST)			
		205 (1205): Hold external PID1 integral component (EPID1-HLD)			
		211 (1211): External PID control 2 ON command (EPID2-ON)			
		212 (1212): Cancel external PID control 2 (%/EPID2)			
		213 (1213): Switch normal/inverse operation under external PID control 2 (EPID2-IVS)			
		214 (1214): Reset external PID2 integral and differential components (EPID2-RST)			
		215 (1215): Hold external PID2 integral component (EPID2-HLD)			
		221 (1221): External PID control 3 ON command (EPID3-ON)			
		222 (1222): Cancel external PID control 3 (%/EPID3)			
		223 (1223): Switch normal/inverse operation under external PID control 3 (EPID3-IVS)			
		224 (1224): Reset external PID3 integral and differential components (EPID3-RST)			
		225 (1225): Hold external PID3 integral component (EPID3-HLD)			
		Setting the value in parentheses () shown above assigns a negative logic output to a terminal. (True if OFF.)			
		Setting the value of 1000s in parentheses () shown above assigns a negative logic input to a terminal.			

C codes: Control Functions of Frequency

Code	Name	Data setting range	Change when running	Data copying	Default setting	
C01	Jump Frequency 1	0.0 to 120.0 Hz	Y	Y	0.0	
C02	2		Y	Y	0.0	
C03	3		Y	Y	0.0	
C04	(Hysteresis width)	0.0 to 30.0 Hz	Y	Y	3.0	
C05	Multistep Frequency 1	0.00 to 120.00 Hz	Y	Y	0.00	
C06	2		Y	Y	0.00	
C07	3		Y	Y	0.00	
C08	4		Y	Y	0.00	
C09	5		Y	Y	0.00	
C10	6		Y	Y	0.00	
C11	7		Y	Y	0.00	
C12	8		Y	Y	0.00	
C13	9		Y	Y	0.00	
C14	10		Y	Y	0.00	
C15	11		Y	Y	0.00	
C16	12		Y	Y	0.00	
C17	13		Y	Y	0.00	
C18	14		Y	Y	0.00	
C19	15		Y	Y	0.00	
C21	Pattern Operation (Mode selection)	0: Carry out a single cycle of the specified pattern operation and stop the inverter output 1: Carry out the specified pattern operation repeatedly and stop the inverter output upon receipt of a stop command. 2: Carry out a single cycle of the specified pattern operation and continue to run at the last reference frequency.	N	Y	0	
C22	Pattern Operation (Stage 1)	0.00 to 6000.00 Hz	Y	Y	0.00	
C23	(Stage 2)	FWD/RED 1 to 4				FWD 1
C24	(Stage 3)					
C25	(Stage 4)					
C26	(Stage 5)					
C27	(Stage 6)					
C28	(Stage 7)					
C30	Frequency Command 2	0: Enable / keys on the keypad 1: Voltage input to terminal [12] (-10 to +10 VDC) 2: Current input to terminal [C1] (4 to 20 mA DC) 3: Sum of voltage and current inputs to terminals [12] and [C1] 5: Voltage input to terminal [V2] (0 to 10 VDC) 7: Terminal command UP/DOWN control 8: Enable / keys on the keypad (balanceless-bumpless switching available) 10: Pattern operation	N	Y	2	
C31	Analog Input Adjustment for [12] (Offset)	-5.0% to 5.0%	Y*	Y	0.0	
C32	(Gain)	0.00% to 200.00%	Y*	Y	100.00	
C33	(Filter time constant)	0.00 to 5.00 s	Y	Y	0.05	
C34	(Gain base point)	0.00% to 100.00%	Y*	Y	100.00	
C35	(Polarity)	0: Bipolar 1: Unipolar	N	Y	1	
C36	Analog Input Adjustment for [C1] (Offset)	-5.0% to 5.0%	Y*	Y	0.0	
C37	(Gain)	0.00% to 200.00%	Y*	Y	100.00	
C38	(Filter time constant)	0.00 to 5.00s	Y	Y	0.05	
C39	(Gain base point)	0.00% to 100.00%	Y*	Y	100.00	
C40	Terminal [C1] Input Range Selection.	0: 4 to 20 mA 1: 0 to 20 mA	N	Y	0	
C41	Analog Input Adjustment for [V2] (Offset)	-5.0% to 5.0%	Y*	Y	0.0	
C42	(Gain)	0.00% to 200.00%	Y*	Y	100.00	
C43	(Filter time constant)	0.00 to 5.00 s	Y	Y	0.05	
C44	(Gain base point)	0.00% to 100.00%	Y*	Y	100.00	
C45	(Polarity)	0: Bipolar 1: Unipolar	N	Y	1	
C53	Selection of Normal/Inverse Operation (Frequency command 1)	0: Normal operation 1: Inverse operation	Y	Y	0	
C55	Analog Input Adjustment for Terminal [12] (Bias value)	-100.00 to 100.00%	Y	Y	0.00	
C56	(Bias base point)	0.00 to 100.00%	Y	Y	0.00	

Code	Name	Data setting range	Change when running	Data copying	Default setting
C58	Analog Input Adjustment for Terminal [I2] (Display unit)	1: none 2: % 4: r/min 7: kW <u>Flowrate</u> 20: m ³ /s 21: m ³ /min 22: m ³ /h 23: L/s 24: L/min 25: L/h <u>Pressure</u> 40: Pa 41: kPa 42: MPa 43: mbar 44: bar 45: mmHg 46: psi (Pound per square inch) 47: mWG 48: inWG <u>Temperature</u> 60: K 61: °C 62: °F <u>Density</u> 80: ppm	Y	Y	2
C59	(Maximum scale)	-999.00 to 0.00 to 9990.00	N	Y	100
C60	(Minimum scale)	-999.00 to 0.00 to 9990.00	N	Y	0.00
C61	Analog Input Adjustment for Terminal [C1] (Bias value)	-100.00 to 100.00%	Y	Y	0.00
C62	(Bias base point)	0.00 to 100.00%	Y	Y	0.00
C64	(Display unit)	Same as C58	Y	Y	2
C65	(Maximum scale)	-999.00 to 0.00 to 9990.00	N	Y	100
C66	(Minimum scale)	-999.00 to 0.00 to 9990.00	N	Y	0.00
C67	Analog Input Adjustment for Terminal [V2] (Bias value)	-100.00 to 100.00%	Y	Y	0.00
C68	(Bias base point)	0.00 to 100.00%	Y	Y	0.00
C70	(Display unit)	Same as C58	Y	Y	2
C71	(Maximum scale)	-999.00 to 0.00 to 9990.00	N	Y	100
C72	(Minimum scale)	-999.00 to 0.00 to 9990.00	N	Y	0.00

Note: Alphabets in the Default setting field denote shipping destination: E (EU), A (Asia), C (China).

P codes: Motor 1 Parameters

Code	Name	Data setting range	Change when running	Data copying	Default setting
P01	Motor 1 (No. of poles)	2 to 22 poles	N	Y1	4
P02	(Rated capacity)	0.01 to 1000.00 kW (when P99 = 0 or 4) 0.01 to 1000.00 HP (when P99 = 1)	N	Y1	*6
P03	(Rated current)	0.00 to 2000.00 A	N	Y1	*6
P04	(Auto-tuning)	0: Disable 1: Tune the motor while it is stopped (%R1, %X) 2: Tune the motor while it is rotating under V/f control (%R1, %X, no-load current)	N	N	0
P05	(Online-tuning)	0: Disable 1: Enable	Y	Y	0
P06	(No-load current)	0.00 to 2000.00 A	N	Y1	*6
P07	(%R1)	0.00% to 50.00%	Y	Y1	*6
P08	(%X)	0.00% to 50.00%	Y	Y1	*6
P10	(Slip compensation response time)	0.01 to 10.00 s	Y	Y1	0.50
P12	(Rated slip frequency)	0.00 to 15.00 Hz	N	Y1	*6
P99	Motor 1 Selection	0: Motor characteristics 0 (Fuji standard motors, 8-series) 1: Motor characteristics 1 (HP rating motors) 4: Other motors	N	Y1	0

The shaded function codes () are applicable to the quick setup.

*6 The motor parameters are automatically set, depending upon the inverter's capacity. See Table B.

H codes: High Performance Functions

Code	Name	Data setting range	Change when running	Data copying	Default setting
H03	Data Initialization	0: Disable initialization 1: Initialize all function code data to factory defaults 2: Initialize motor 1 parameters 10: Initialize real-time clock information 11: Initialize function code data except communication function codes 12: Initialize U code data (customizable logic function codes)	N	N	0
H04	Auto-reset (Times)	OFF: Disable; 1 to 20	Y	Y	OFF
H05	(Reset interval)	0.5 to 60.0 s	Y	Y	5.0
H06	Cooling Fan ON/OFF Control	0: Disable (Always in operation) 1: Enable (ON/OFF controllable)	Y	Y	1
H07	Acceleration/Deceleration Pattern	0: Linear 1: S-curve (Weak) 2: S-curve (Strong) 3: Curvilinear	Y	Y	0
H08	Rotational Direction Limitation	0: Disable 1: Enable (Reverse rotation inhibited) 2: Enable (Forward rotation inhibited) 3: Enable (Reverse rotation inhibited, setting only) 4: Enable (Forward rotation inhibited, setting only)	N	Y	0
H09	Starting Mode (Auto search)	0: Disable 1: Enable (At restart after momentary power failure) 2: Enable (At restart after momentary power failure and at normal start)	N	Y	0
H11	Deceleration Mode	0: Normal deceleration 1: Coast-to-stop	Y	Y	0
H12	Instantaneous Overcurrent Limiting (Mode selection)	0: Disable 1: Enable	Y	Y	1
H13	Restart Mode after Momentary Power Failure (Restart time)	0.1 to 20.0 s	Y	Y1	*2
H14	(Frequency fall rate)	Inherit: With the selected deceleration time 0.01 to 100.00 Hz/s Auto: With the current limiter	Y	Y	Auto
H15	(Continuous running level)	400 to 600 V	Y	Y1	.470
H16	(Allowable momentary power failure time)	0.0 to 30.0 s Auto: Automatically determined by inverter	Y	Y	Auto
H26	Thermistor (for motor) (Mode selection)	0: Disable 1: PTC (The inverter immediately trips with OH4 displayed.) 2: PTC (The inverter issues output signal THM and continues to run.)	Y	Y	0
H27	(Level)	0.00 to 5.00 V	Y	Y	0.35
H30	Communications Link Function (Mode selection)	Frequency command Run command 0: F01/C30 F02 1: RS-485 (Port 1) F02 2: F01/C30 RS-485 (Port 1) 3: RS-485 (Port 1) RS-485 (Port 1) 4: RS-485 (Port 2) F02 5: RS-485 (Port 2) RS-485 (Port 1) 6: F01/C30 RS-485 (Port 2) 7: RS-485 (Port 1) RS-485 (Port 2) 8: RS-485 (Port 2) RS-485 (Port 2)	Y	Y	0
H42	Capacitance of DC Link Bus Capacitor	Meas (Measure initial value), Failed (Measurement failed), 2 to 65535 Indication for replacement of DC link bus capacitor	Y	N	--
H43	Cumulative Run Time of Cooling Fan	Indication for replacement of cooling fan 0 to 99990 (in units of 10 hours)	Y	N	--
H44	Startup Counter for Motor 1	Indication of cumulative startup count 0 to 65535	Y	N	--
H45	Mock Alarm	0: Disable 1: Enable (Once a mock alarm occurs, the data automatically returns to 0.)	Y	N	0
H46	Starting Mode (Auto search delay time 2)	0.1 to 20.0 s	Y	Y1	*6
H47	Initial Capacitance of DC Link Bus Capacitor	Meas (Measure initial value), Failed (Measurement failed), 2 to 65535 Indication for replacement of DC link bus capacitor	Y	N	--
H48	Cumulative Run Time of Capacitors on Printed Circuit Boards	Indication for replacement of capacitors 0 to 99990 (in units of 10 hours)	Y	N	--
H49	Starting Mode (Auto search delay time 1)	0.0 to 10.0 s	Y	Y	0.0

*2 The factory default differs depending upon the inverter's capacity. See Table A.

*6 The motor rated current is automatically set. See Table B.

Code	Name	Data setting range	Change when running	Data copying	Default setting
H50	Non-linear V/f Pattern 1 (Frequency)	OFF: Cancel, 0.1 to 120.0 Hz	N	Y	*7
H51	(Voltage)	0 to 500: Output an AVR-controlled voltage	N	Y1	8
H52	Non-linear V/f Pattern 2 (Frequency)	OFF: Cancel, 0.1 to 120.0 Hz	N	Y	OFF
H53	(Voltage)	0 to 500: Output an AVR-controlled voltage	N	Y1	0
H56	Deceleration Time for Forced Stop	0.00 to 3600 s	Y	Y	20.0
H61	Multistep Frequency + UP/DOWN Control (Initial frequency setting)	1: Last UP/DOWN command value on releasing the run command 13 to 106: Multistep frequency + UP/DOWN command (Initial value to be preserved)	N	Y	1
H63	Low Limiter (Mode selection)	0: Limit by F16 (Frequency limiter: Low) and continue to run 1: If the output frequency lowers below the one limited by F16 (Frequency limiter: Low), decelerate to stop the motor.	Y	Y	0
H64	(Lower limiting frequency)	Inherit: Depends on F16 (Frequency limiter, Low) 0.1 to 60.0 Hz	Y	Y	2.0
H68	Slip Compensation 1 (Operating conditions)	0: Enable during ACC/DEC and at base frequency or above 1: Disable during ACC/DEC and enable at base frequency or above 2: Enable during ACC/DEC and disable at base frequency or above 3: Disable during ACC/DEC and at base frequency or above	N	Y	0
H69	Automatic Deceleration (Mode selection)	0: Disable 2: Torque limit control with Force-to-stop if actual deceleration time exceeds three times the specified one 3: DC link bus voltage control with Force-to-stop if actual deceleration time exceeds three times the specified one 4: Torque limit control with Force-to-stop disabled 5: DC link bus voltage control with Force-to-stop disabled	Y	Y	0
H70	Overload Prevention Control	OFF: Cancel Inherit: Follow the selected deceleration time 0.01 to 100.00 Hz/s	Y	Y	OFF
H71	Deceleration Characteristics	0: Disable 1: Enable	Y	Y	0
H72	Main Power Down Detection	0: Disable 1: Enable	Y	Y	1
H76	Torque Limiter for Braking (Frequency increment limit)	0.0 to 120.0 Hz	Y	Y	5.0
H77	Service Life of DC Link Bus Capacitor (Remaining time)	0 to 43800 (in units of 10 hours)	Y	N	-
H78	Maintenance Interval (M1)	OFF: Disable 10 to 99990 (in units of 10 hours)	Y	N	43800
H79	Preset Startup Count for Maintenance (M1)	OFF: Disable 1 to 65535	Y	N	OFF
H80	Output Current Fluctuation Damping Gain for Motor 1	0.00 to 1.00	Y	Y	0.20
H89	Reserved *9	0, 1	Y	Y	1
H90	Reserved *9	0, 1	Y	Y	0
H91	Current Input Wire Break Detection	OFF: Disable, 0.1 to 60.0 s	Y	Y	OFF
H92	Continuity of Running (P)	0.000 to 10.000 times Auto	Y	Y1	Auto
H93	(I)	0.010 to 10.000 s Auto	Y	Y1	Auto
H94	Cumulative Motor Run Time 1	0 to 99990 (The cumulative run time can be modified or reset in units of 10 hours.)	N	N	-
H95	DC Braking (Braking response mode)	0: Slow 1: Quick	Y	Y	1
H96	STOP Key Priority/Start Check Function	Data STOP key priority Start check function 0: Disable Disable 1: Enable Disable 2: Disable Enable 3: Enable Enable	Y	Y	0
H97	Clear Alarm Data	0: Disable 1: Enable (Setting "1" clears alarm data and then returns to "0.")	Y	N	0
H98	Protection/Maintenance Function (Mode selection)	0 to 255 Bit 0: Lower the carrier frequency automatically (0: Disabled; 1: Enabled) Bit 1: Detect input phase loss (0: Disabled; 1: Enabled) Bit 2: Detect output phase loss (0: Disabled; 1: Enabled) Bit 3: Select life judgment threshold of DC link bus capacitor (0: Factory default level; 1: User setup level) Bit 4: Judge the life of DC link bus capacitor (0: Disabled; 1: Enabled) Bit 5: DC fan lock detection (0: Disabled; 1: Enabled) Bit 7: Switch IP21/IP55 enclosure (0: IP21; 1: IP55)	Y	Y	VXA-M VXA-L

*7 0.0 (Cancel) for inverters with a capacity of 22 kW or below; 5.0 Hz for those with 30 kW or above.

*8 0 V for inverters with a capacity of 22 kW or below; 40 V for inverters with 30 kW or above, respectively.

*9 These function codes are reserved for particular manufacturers. Unless otherwise specified, do not access these function codes.

Code	Name	Data setting range	Change when running	Data copying	Default setting
H104	Number-of-retry Clear Time	0.5 to 5.0 (min)	Y	Y	5.0
H105	Retry Target Selection	0 to 255 Bit 0: OC1 to OC3 Bit 1: OV1 to OV3 Bit 2: OH1 OH3 OLU Bit 3: - Bit 4: OL1 Bit 5: OH4 Bit 6: - Bit 7: -	Y	Y	225
H106	Retry Target Selection 2	0 to 255 Bit 0: OH2 Bit 1: LV Bit 2: - Bit 3: - Bit 4: - Bit 5: - Bit 6: - Bit 7: -	Y	Y	0
H110	Input Phase Loss Protection Avoidance Operation (Mode selection)	0: Disable 1: Enable (Decrease output frequency)	Y	Y	0
H112	Voltage Shortage Avoidance Operation (Mode selection)	0: Disable 1: Enable (Decrease output frequency)	Y	Y	0
H114	Automatic Deceleration (Operation level)	0.0 to 50.0% Auto	Y	Y	Auto
H116	Fire Mode (Mode selection)	0: FMS: ON 1: FMS toggle method 2: FMS latch method	N	Y	0
H117	(Confirmation time)	0.5 to 10.0 s * Set ON/OFF setting time for FMS signals.	Y	Y	3.0
H118	(Reference frequency)	Inherit: Follow the ordinary reference frequency specified with F01, etc. 0.1 to 120.0 Hz	Y	Y	Inherit
H119	(Rotation direction)	0: Follow the run command specified with F02, etc. 2: Forward rotation 3: Reverse rotation	N	Y	0
H120	(Start method)	0: Follows the start methods specified with instant power failure restart 1: Auto search	Y	Y	0
H121	(Reset interval)	0.5 to 20.0 s	Y	Y	5.0
H181	Light Alarm Selection 1	0 to 255 Bit 0: - Bit 1: OH2 Bit 2: OH3 Bit 3: - Bit 4: - Bit 5: OL1 Bit 6: - Bit 7: -	Y	Y	0
H182	Light Alarm Selection 2	0 to 255 Bit 0: - Bit 1: - Bit 2: Er4 Bit 3: Er5 Bit 4: ErB Bit 5: ErP Bit 6: - Bit 7: -	Y	Y	0
H183	Light Alarm Selection 3	0 to 255 Bit 0: - Bit 1: - Bit 2: - Bit 3: CoF, PV1, PV2, PVA, PVb, PVC Bit 4: FAL Bit 5: OL Bit 6: OH Bit 7: LIF	Y	Y	0

Code	Name	Data setting range	Change when running	Data copying	Default setting
H184	Light Alarm Selection 4	0 to 255 Bit 0: rEF Bit 1: PA1, PA2, PAA, PAb, PAC Bit 2: UTL Bit 3: PTC Bit 4: rTE Bit 5: CnT Bit 6: - Bit 7: Lob, dtL	Y	Y	128
H197	User Password 1 (Mode selection)	0: Disclose all function codes but prohibit any change 1: Disclose function codes selected for quick setup only and allow change * This specifies the protection of user password 1.	Y	Y	0

J codes: Application Functions I

Code	Name	Data setting range	Change when running	Data copying	Default setting
J21	Dew Condensation Prevention (Duty)	1% to 50%	Y	Y	1
J22	Commercial Power Switching Sequence	0: Keep inverter operation (Stop due to alarm) 1: Automatically switch to commercial-power operation	N	Y	0

J1 codes: PID Control I

Code	Name	Data setting range	Change when running	Data copying	Default setting
J101	PID Control 1 (Mode selection)	0: Disable 1: Enable (Process control, normal operation) 2: Enable (Process control, inverse operation)	N	Y	0
J102	(Command selection)	0: Keypad (↶/↷ key) 1: PID command 1 (Analog input: Terminals [12], [C1] and [V2]) 3: UP/DOWN 4: Command via communications link (Use function code S13)	N	Y	0
J103	(Feedback selection)	1: PID control 1 feedback value 10: Addition (PID control 1 feedback value + PID control 2 feedback value) 11: Difference (PID control 1 feedback value - PID control 2 feedback value) 12: Average (PID control 1 feedback value, PID control 2 feedback value) 13: Maximum (PID control 1 feedback value, PID control 2 feedback value) 14: Minimum (PID control 1 feedback value, PID control 2 feedback value)	N	Y	1
J104	(Deviation selection)	0: (J102)-(J103) 1: Selection of maximum (selection of maximum for PID control 1 and 2 deviation) 2: Selection of minimum (selection of minimum for PID control 1 and 2 deviation)	N	Y	0

Code	Name	Data setting range	Change when running	Data copying	Default setting
J105	PID Control 1 (Display unit)	0: Based on the unit/scale of the PID control 1 feedback amount 1: none 2: % 4: r/min 7: kW <u>Flowrate</u> 20: m ³ /s 21: m ³ /min 22: m ³ /h 23: L/s 24: L/min 25: L/h <u>Pressure</u> 40: Pa 41: kPa 42: MPa 43: mbar 44: bar 45: mmHg 46: psi (Pound per square inch) 47: mWG 48: inWG <u>Temperature</u> 60: K 61: °C 62: °F <u>Density</u> 80: ppm	N	Y	0
J106	(Maximum scale)	-999.00 to 0.00 to 9990.00	N	Y	100
J107	(Minimum scale)	-999.00 to 0.00 to 9990.00	N	Y	0.00
J110	P (Gain)	0.000 to 30.000 times	Y	Y	0.100
J111	I (Integral time)	0.0 to 3600.0 s	Y	Y	0.0
J112	D (Differential time)	0.00 to 600.00 s	Y	Y	0.00
J113	(Feedback filter)	0.0 to 900.0 s	Y	Y	0.5
J114	(Anti-reset wind-up)	OFF: Disable 0.01 to 9990.00 *10	Y	Y	OFF
J118	(Upper limit of PID process output)	0.0 to 120.0 Hz; Inherit (Depends on setting of F15)	Y	Y	Inherit
J119	(Lower limit of PID process output)	0.0 to 120.0 Hz; Inherit (Depends on setting of F15)	Y	Y	Inherit
J121	(Alarm output selection)	0: Absolute-value alarm 1: Absolute-value alarm (with Hold) 2: Absolute-value alarm (with Latch) 3: Absolute-value alarm (with Hold and Latch) 4: Deviation alarm 5: Deviation alarm (with Hold) 6: Deviation alarm (with Latch) 7: Deviation alarm (with Hold and Latch)	Y	Y	0
J122	(Upper level alarm (AH))	-999.00 to 0.00 to 9990.00 *10 OFF	Y	Y	OFF
J124	(Lower level alarm (AL))	-999.00 to 0.00 to 9990.00 *10 OFF	Y	Y	OFF
J127	(Feedback failure detection (Mode selection))	0: Disable (Turns ON output signals (PV1-OFF) and continues operation.) 1: Enable (Free run stop (PV1 trip)) 2: Enable (Deceleration and stop (PV1 trip)) 3: Enable (Continuation of operation at the maximum frequency (upper limit frequency)) 4: Enable (Continuation of operation at the minimum frequency (lower limit frequency)) 5: Enable (Continuation of operation at the frequency used when failure is detected.) 6: Enable (Shift to PID control 2 (PID control 1 is restored when failure is recovered from.))	Y	Y	0

*10 The upper and lower level values are restricted by the maximum and minimum scales.

Code	Name	Data setting range	Change when running	Data copying	Default setting
J128	(Feedback failure continuation duration)	0 to 3600 s; Cont. Cont. (Mode selection: continuation of operation specified with J127. PV 1 trip after stop (output shutoff).)	Y	Y	Cont.
J129	(Feedback failure upper-limit)	-999.00 to 0.00 to 9990.00 *10 Auto: 105% equivalent	Y	Y	Auto
J130	(Feedback failure lower-limit)	-999.00 to 0.00 to 9990.00 *10 Auto: -5% equivalent	Y	Y	Auto
J131	(Feedback failure detection time)	0.0 to 300.0 s	Y	Y	0.1
J136	PID Multistep Command (Multistep command 1)	-999.00 to 0.00 to 9990.00	Y	Y	0.00
J137	(Multistep command 2)		Y	Y	0.00
J138	(Multistep command 3)		Y	Y	0.00
J143	Boost Function (Mode selection)	0: Disable (disabled at the time of initiation) 1: Enable ("enabled at the time of initiation" plus "only at the time of PID control") 2: Enable (always enabled at the time of initiation) 3: Enable ("only first initiation with power ON" plus "only at the time of PID control") 4: Enable (only at the time of first initiation with power ON)	Y	Y	0
J144	(Operation frequency)	Inherit: Maximum frequency 0.1 to 120.0 Hz	Y	Y	Inherit
J145	(Acceleration time)	Inherit; 0.01 to 3600 s Inherit: The currently effective acceleration time is followed. * Acceleration time from 0 Hz to Fmax should be specified. * In the case of J145 ≠ 0.00, the acceleration/deceleration time selection function is disabled.	Y	Y	Inherit
J146	(Operation time)	0.0 to 3600.0 s * Specify the time including acceleration time. * 0.0 Time period while the boost command BST is ON (When BST is not used, this is used as the time until the operation frequency is reached.)	Y	Y	0.0
J147	(Cancel PV level)	-999.00 to 0.00 to 9990.00 *10 OFF	Y	Y	OFF
J149	Slow Flowrate Stop Function (Mode selection)	0: Disable (display of OFF) 1: Manual operation (stop judgment: MV) 2: Manual operation (stop judgment: PV) 11: Auto operation 1 (stop judgment: MV): Deviation detection method 12: Auto operation 1 (stop judgment: PV): Deviation detection method 21: Auto operation 2 (stop judgment: MV): Flow sensor detection method 22: Auto operation 2 (stop judgment: PV): Flow sensor detection method	N	Y	OFF
J150	(Operation level)	J149 = MV: 0.00 to 120.00 Hz, Auto J149 = PV: 0.00 to 9990.00, Auto *10	Y	Y	Auto
J151	(Elapsed time)	0 to 60 s	Y	Y	0
J152	(Auto-operation frequency lower-limit)	0.0 to 120.0 Hz	Y		0.0
J153	(Pressurization starting frequency)	0.0 to 120.0 Hz	Y	Y	0.0
J154	(Pressurizing time)	0 to 60 s	Y	Y	0
J156	(Initiation inhibition time)	0 to 3600 s	Y	Y	0
J157	(Cancel frequency)	OFF 0.0 to 120.0 Hz	Y		0.0
J158	(Cancel deviation level 1)	OFF: Disable 0.01 to 9990.00 *10	Y	Y	OFF
J159	(Cancel delay timer)	0 to 3600s	Y	Y	0
J160	(Cancel deviation level 2)	OFF: Disable 0.01 to 9990.00 *10	Y	Y	OFF

*10 The upper and lower level values are restricted by the maximum and minimum scales.

Code	Name	Data setting range	Change when running	Data copying	Default setting
J163	Flow Sensor (Input selection)	0: Inherit Follow analog input selected by E61, E62, and E63. 1: PV4 20: m ³ /s 21: m ³ /min 22: m ³ /h 23: L/s 24: L/min 25: L/h * Data 20 or larger is to be used for connection of customizable logic.	N	Y	0
J164	(ON level)	0.00 to 9990.00 *10 OFF * If J163 = 20 or above, no scale can be defined, so the setting range should be from the minimum to maximum.	Y	Y	OFF
J165	(OFF level)	0.00 to 9990.00 *10 OFF * If J163 = 20 or above, no scale can be defined, so the setting range should be from the minimum to maximum.	Y	Y	OFF
J166	(Input filter)	0.00 to 5.00s	Y	Y	0.20
J168	Control of Maximum Starts Per Hour (Input selection)	0: Disable 1: Alarm 2: Warning output	Y	Y	0
J169	(Number of slow flowrate stop detections)	1 to 10	Y	Y	1
J176	Dry Pump Protection (Input selection)	0: Disable 1: Alarm 2: Warning output	Y	Y	0
J177	(Detection current)	OFF: Disable 1% to 150% of the inverter rated current	Y	Y	OFF
J178	(Deviation)	OFF: Disable 0.01 to 9990.00 *10	Y	Y	OFF
J179	(Flow sensor)	0: Disable 1: Enable	Y	Y	0
J180	(Detection timer)	0 to 600s	Y	Y	0
J182	End of Curve Protection (Input selection)	0: Disable 1: Alarm 2: Warning output	Y	Y	0
J183	(Detection current)	0.00: Disable 1% to 150% of the inverter rated current	Y	Y	OFF
J184	(Deviation)	0.00: Disable 0.01 to 9990.00 *10	Y	Y	OFF
J185	(Flow sensor)	0: Disable 1: Enable	Y	Y	0
J186	(Detection timer)	0 to 600s	Y	Y	0
J188	Filter Clogging Prevention/ Anti Jam Function (Input selection)	0: Disable 1: Enable (Anti jam protection, inverter stop with rLo trip) 2: Enable (Filter clogging trouble, inverter stop with FoL trip) 3: Enable (While warning (filter clogging trouble) is output, operation is continued.)	Y	Y	0
J189	Filter Clogging Prevention Function (Reverse operation cycle time)	OFF: Disable 1 to 10000 h	Y	Y	720
J190	(Load resistance current)	OFF: Disable 1% to 150% of the inverter rated current	Y	Y	OFF
J191	(Load resistance PV signal)	-999.00 to 0.00 to 9990.00 *10 OFF	Y	Y	OFF
J192	(Load resistance detection timer)	0 to 600 s	Y	Y	0
J193	Filter Clogging Prevention/ Anti Jam Function (Reverse rotation running frequency)	0.0 to 120.0 Hz	Y	Y	5.0
J194	(Reverse rotation running time)	0 to 600 s	Y	Y	30
J195	(Number of allowable reverse runs)	1 to 10 times	Y	Y	3

*10 The upper and lower level values are restricted by the maximum and minimum scales.

J4 codes: Pump APP Functions

Code	Name	Data setting range	Change when running	Data copying	Default setting
J401	Pump Control Mode Selection	0: Disable 1: Enable (Inverter-driven motor fixation system) 2: Enable (Inverter-driven motor floating system) 3: Enable (Inverter-driven motor floating + commercial power-driven motor system) 52: Enable (Communications-linked inverter-driven motor floating system) 54: Enable (Communications-linked all motors simultaneous PID control system)	N	Y	0
J402	Communication Master/Slave Selection	0: Communication master inverter 1: Communication slave inverter	N	Y	1
J403	Number of Slaves	1 or 2 units * Set for a master only.	N	Y	1
J404	Master Input Permeation Selection	0000H to 01FFH (hexadecimal) Bit 0: FWD Bit 1: REV Bit 2: X1 Bit 3: X2 Bit 4: X3 Bit 5: X4 Bit 6: X5 Bit 7: X6 Bit 8: X7 * The inverter sends the master terminal input info to the slave. * The slave stores the received data to S06 after masking.	N	Y	0
J411	Motor 1 Mode Selection	0: Disable (off at all times) 1: Enable	Y	Y	0
J412	Motor 2 Mode Selection	2: Forced drive ON (forced commercial power drive)			
J413	Motor 3 Mode Selection				
J414	Motor 4 Mode Selection				
J415	Motor 5 Mode Selection				
J416	Motor 6 Mode Selection				
J417	Motor 7 Mode Selection				
J418	Motor 8 Mode Selection				
J425	Motor Switching Procedure	0: Fixation procedure 1: Equal operating time (Cumulative run time of each motor is equalized.) 2: Fixation procedure (Switching the motor at slow flowrate stop) 3: Equal operating time (Switching the motor at slow flowrate stop.)	N	Y	0
J430	How to Stop the Motor	0: Turn all the inverter and commercial power OFF. 1: Turn the inverter only OFF, except when an alarm has occurred. 2: Turn the inverter only OFF, also when an alarm has occurred.	Y	Y	0
J435	Motor Regular Switching Mode Selection	1: Inverter-driven pumps are subject to switching. 2: Commercial power-driven pumps are subject to switching. 3: All pumps (inverter-driven pumps/commercial power-driven pumps) are subject to switching.	Y	Y	1
J436	Motor Regular Switching Time	OFF: 0.1 to 720.0 h: Test OFF: Disable 0.1 to 720.0 h: Enable: (Switching time) Test: Enable (Switching time fixed to three minutes)	Y	Y	OFF
J437	Motor Regular Switching Signal Output Time	0.00 to 600.00 s Signal output time	Y	Y	0.10
J450	Motor Increase Judgment (Judgment frequency)	0 to 120 Hz, Inherit Inherit: Depends on J118	Y	Y	Inherit
J451	(Duration time)	0.00 to 3600.00 s	Y	Y	0.00
J452	Motor Decrease Judgment (Judgment frequency)	0 to 120 Hz, Inherit Inherit: Depends on J119	Y	Y	Inherit
J453	(Duration time)	0.00 to 3600.00 s	Y	Y	0.00
J454	Contactor Restart Time when Switching the Motor	0.01 to 2.00 s	Y	Y	0.10
J455	Motor Increase Switching Time (Deceleration time)	Inherit: Depends on F08 0.01 to 3600.00 s	Y	Y	Inherit
J456	Motor Increase Switching Level	0 to 100%	Y	Y	0
J457	Motor Increase PID Control Start Frequency	0 to 120 Hz, Inherit Depends on J452	Y	Y	Inherit
J458	Motor Decrease Switching Time (Acceleration time)	Inherit: Depends on F07 0.01 to 3600.00 s	Y	Y	Inherit

Code	Name	Data setting range	Change when running	Data copying	Default setting
J459	Motor Decrease Switching Level	0 to 100%, Inherit Inherit: Depends on J456	Y	Y	Inherit
J460	Motor Decrease PID Control Start Frequency	0 to 120 Hz, Inherit Inherit: Depends on J450	Y	Y	Inherit
J461	Motor Increase/Decrease Switching Judgment Non-responsive Area Width	OFF, 0.1 to 50.0% OFF: Disable 0.1 to 50.0%	Y	Y	OFF
J462	Failure Inverter Judgment Time	OFF, 0.5 to 600.0 s	Y	Y	5.0
J465	Auxiliary Motor (Frequency operation level)	0.1 to 120.0 Hz OFF: Disable	Y	Y	50.0
J466	(Hysteresis width)	0.0 to 120.0 Hz	Y	Y	1.0
J467	(PV operation level)	0.01 to 9990.00 *10 OFF: Disable	Y	Y	OFF
J468	(Connection timer)	0.00 to 2.00 s	Y	Y	0.00
J469	(Interrupting timer)	0.00 to 2.00 s	Y	Y	0.00
J480	Motor Cumulative Run Time (Motor 0)	0 to 65535	Y	N	0
J481	(Motor 1)	For adjustment at the replacement time.			
J482	(Motor 2)				
J483	(Motor 3)				
J484	(Motor 4)				
J485	(Motor 5)				
J486	(Motor 6)				
J487	(Motor 7)				
J488	(Motor 8)				
J490	Y Terminal ON Maximum Cumulation Count (Y1 Y2)	0.000 to 9999 (The display of "1.000" indicates 1000 times.)	Y	N	0.000
J491	(Y3 Y4)				
J492	Relay ON Maximum Cumulation Count (Y5A 30AB)				
J493	(Y6RY to Y12RY)				

K codes: Keypad Functions

Code	Name	Data setting range	Change when running	Data copying	Default setting
K01	LCD Monitor (Language selection)	0: Japanese 1: English 2: German 3: French 4: Spanish 5: Italian 6: Chinese 8: Russian (Available soon) 9: Greek (Available soon) 10: Turkish (Available soon) 11: Polish 12: Czech 13: Swedish 14: Portuguese (Available soon) 15: Dutch (Available soon) 16: Malay 17: Vietnamese (Available soon) 18: Thai (Available soon) 19: Indonesian (Available soon) 100: User-customized language (Available soon)	Y	Y	1
K02	Backlight OFF Time	OFF: Always OFF 1 to 30 min.: Automatic OFF time	Y	Y	5
K03	LCD Monitor (Backlight brightness control)	0 (Dark) to 10 (Light)	Y	Y	5
K04	(Contrast control)	0 (Light) to 10 (Dark)	Y	Y	5
K08	LCD Monitor Status Display/Hide Selection	0: Hide 1: Display	Y	Y	1
K10	Main Monitor (Display item selection)	0: Speed monitor (select by K11) 13: Output current 14: Output voltage 18: Calculated torque 19: Input power 25: Load factor 26: Motor output 27: Analog input monitor in physical quantity 35: Input watt-hour (The unit depends on K31.) 50: PID command (final) in physical quantity 51: PID feedback amount (final) in physical quantity 52: PID output 53: PID control 1 command in physical quantity 54: PID control 1 feedback amount in physical quantity 55: PID control 2 command in physical quantity 56: PID control 2 feedback amount in physical quantity 60: External PID control 1 command (final) in physical quantity 61: External PID control 1 feedback amount (final) in physical quantity 62: External PID control 1 output in % 63: External PID control 1 manual command in % 64: External PID control 1 command in physical quantity 65: External PID control 1 feedback amount in physical quantity 70: External PID control 2 command in physical quantity 71: External PID control 2 feedback amount in physical quantity 72: External PID control 2 output in % 73: External PID control 2 manual command in % 80: External PID control 3 command in physical quantity 81: External PID control 3 feedback amount in physical quantity 82: External PID control 3 output in % 83: External PID control 3 manual command in %	Y	Y	0
K11	Main Monitor (Speed monitor item)	1: Output frequency 1 (before slip compensation) 2: Output frequency 2 (after slip compensation) 3: Reference frequency 4: Motor speed in r/min 5: Load shaft speed in r/min 8: Display speed in %	Y	Y	1

Code	Name	Data setting range	Change when running	Data copying	Default setting
K12	Main Monitor (Display when stopped)	0: Reference value 1: Output value	Y	Y	0
K15	Sub Monitor (Display type)	0: Numeric values 1: Bar charts	Y	Y	0
K16	Sub Monitor 1 (Display item selection)	*Refer to K10 (= 13 to 83) and K11 (= 1 to 8).	Y	Y	13
K17	Sub Monitor 2 (Display item selection)		Y	Y	19
K20	Bar Chart 1 (Display item selection)	1: Output frequency 1(before slip compensation)	Y	Y	1
K21	Bar Chart 2 (Display item selection)	13: Output current	Y	Y	13
K22	Bar Chart 3 (Display item selection)	14: Output voltage 18: Calculated torque 19: Input power 25: Load factor 26: Motor output	Y	Y	19
K29	Display Filter	0.0 to 5.0 s	Y	Y	0.5
K30	Coefficient for Speed Indication	0.01 to 200.00	Y	Y	30.00
K31	Display Unit for Input Watt-hour Data	0: kWh 1: MWh	Y	Y	0
K32	Display Coefficient for Input Watt-hour Data	OFF: Cancel or reset 0.001 to 9999.000	Y	Y	0.010
K33	Long-term, Input Watt-hour Data Monitor	OFF: Cancel or reset 1: Hourly 2: Daily 3: Weekly 4: Monthly	Y	Y	4
K81	Date Format	0: Y/M/D (year/month/day) 1: D/M/Y (day/month/year) 2: M/D/Y (month/day/year) 3: MD, Y (Month day, year)	Y	Y	1
K82	Time Format	0: 24-hour format (Time : Minute : Second) 1: 12-hour format (Time : Minute : Second AM/PM) 2: 12-hour format (AM/PM Time : Minute : Second)	Y	Y	0
K83	Daylight Saving Time (Summer time)	0: Disable 1: Enable (+ 1 hour) 2: Enable (+ 30 minutes)	Y	Y	0
K84	(Start date)	Possible to specify in the special menu.	Y	Y	0800H
K85	(End date)		Y	Y	0800H
K91	Shortcut Key Function for (◀) in Running Mode (Selection screen)	0: OFF (Disable) 11 to 99	Y	Y	OFF
K92	Shortcut Key Function for (▶) in Running Mode (Selection screen)	0: OFF (Disable) 11 to 99	Y	Y	64

o codes: Option Functions

Code	Name	Data setting range	Change when running	Data copying	Default setting
o01	Terminal [Y6A/B/C] Function (Relay output)	Same as E20.	N	Y	10
o02	Terminal [Y7A/B/C] Function		N	Y	6
o03	Terminal [Y8A/B/C] Function		N	Y	25
o04	Terminal [Y9A/B/C] Function		N	Y	26
o05	Terminal [Y10A/B/C] Function		N	Y	28
o06	Terminal [Y11A/B/C] Function		N	Y	36
o07	Terminal [Y12A/B/C] Function		N	Y	37
o09	Pt Channel (Display unit)	<u>Temperature</u> 60: K 61: °C 62: °F	Y	Y	61
o10	Pt Channel 1 (Sensor type)	0: Pt100 1: Jpt100	Y	Y	0
o11	(Extended functions)	0: No extended function assigned 5: PID feedback value 1 30: PID feedback value 2 42: External PID feedback value 1 45: External PID feedback value 2 48: External PID feedback value 3	N	Y	0
o12	(Filter)	0.00 to 100.0 s	Y	Y	1.0
o15	Pt Channel 2 (Sensor type)	Same as o10.	N	Y	0
o16	(Extended functions)	Same as o11.	N	Y	0
o17	(Filter)	Same as o12.	Y	Y	1.0
o27	Communications Error Processing	0: Immediately trip with alarm Er5 1: Run for the period specified by timer o28 and then trip with alarm Er5 2: Retry during the period specified by timer o28. If the retry fails, immediately trip with alarm Er5. 3: Continue to run. After recovery from the error, run according to communications command 4 to 9: Same as o27 = 0. 10: Decelerate to a stop and trip with alarm Er5 11: Run for the period specified by timer o28, decelerate to a stop, and then trip with alarm Er5 12: Retry during the period specified by timer o28. If the retry fails, decelerate to a stop. If it succeeds, continue to run according to communications command 13 to 15: Same as when o27 = 3.	Y	Y	0
o28	(Timer)	0.0 to 60.0 s	Y	Y	0.0
o30	Bus configuration parameter 01	0 to 255 Functions of o30 to o39 differ depending upon the bus option type. For details, refer to the instruction manual of each bus option.	N	Y	0
o31	Bus configuration parameter 02	Same as o30.	N	Y	0
o32	Bus configuration parameter 03		N	Y	0
o33	Bus configuration parameter 04		N	Y	0
o34	Bus configuration parameter 05		N	Y	0
o35	Bus configuration parameter 06		N	Y	0
o36	Bus configuration parameter 07		N	Y	0
o37	Bus configuration parameter 08		N	Y	0
o38	Bus configuration parameter 09		N	Y	0
o39	Bus configuration parameter 10		N	Y	0
o40	Function Code Assignment 1 for Write	0, 1 to 65535 0: No assignment Data mapped I/O (write) Whether or not to support the I/O or the number of supports differs depending upon the bus option type. For the data configuration procedure, refer to the instruction manual of each bus option.	N	Y	0
o41	Function Code Assignment 2 for Write	Same as o40.	N	Y	0
o42	Function Code Assignment 3 for Write		N	Y	0
o43	Function Code Assignment 4 for Write		N	Y	0
o44	Function Code Assignment 5 for Write		N	Y	0
o45	Function Code Assignment 6 for Write		N	Y	0
o46	Function Code Assignment 7 for Write		N	Y	0
o47	Function Code Assignment 8 for Write		N	Y	0

Code	Name	Data setting range	Change when running	Data copying	Default setting
o48	Function Code Assignment 1 for Read	0, 1 to 65535 0: No assignment Data mapped I/O (read) Whether or not to support the I/O or the number of supports differs depending upon the bus option type. For the data configuration procedure, refer to the instruction manual of each bus option.	N	Y	0
o49	Function Code Assignment 2 for Read	Same as o48.	N	Y	0
o50	Function Code Assignment 3 for Read		N	Y	0
o51	Function Code Assignment 4 for Read		N	Y	0
o52	Function Code Assignment 5 for Read		N	Y	0
o53	Function Code Assignment 6 for Read		N	Y	0
o54	Function Code Assignment 7 for Read		N	Y	0
o55	Function Code Assignment 8 for Read		N	Y	0
o56	Function Code Assignment 9 for Read		N	Y	0
o57	Function Code Assignment 10 for Read		N	Y	0
o58	Function Code Assignment 11 for Read		N	Y	0
o59	Function Code Assignment 12 for Read		N	Y	0
o60	Terminal [32] (Function)		Same as E61.	N	Y
o61	(Offset)	-5.0 to 5.0%	Y	Y	0.0
o62	(Gain)	0.00 to 200.00%	Y	Y	100.00
o63	(Filter setting)	0.00 to 5.00 s	Y	Y	0.05
o64	(Gain base point)	0.00 to 100.00%	Y	Y	100.00
o65	(Polarity)	0: Bipolar 1: Unipolar	N	Y	1
o66	(Bias value)	-100.00 to 100.00%	Y	Y	0.00
o67	(Bias base point)	0.00 to 100.00%	Y	Y	0.00
o69	(Display unit)	Same as J105. (Note that the data setting range starts with "1.")	N	Y	2
o70	(Maximum scale)	-999 to 0.00 to 9990	N	Y	100
o71	(Minimum scale)	-999 to 0.00 to 9990	N	Y	0.00
o75	Terminal [C2] (Current range)	0: 4-20 mA 1: 0-20 mA	N	Y	0
o76	(Function)	Same as E61.	N	Y	0
o77	(Offset)	-5.0 to 5.0%	Y	Y	0.0
o78	(Gain)	0.00 to 200.00%	Y	Y	100.00
o79	(Filter time constant)	0.00 to 5.00 s	Y	Y	0.05
o81	(Gain base point)	0.00 to 100.00%	Y	Y	100.00
o82	(Bias value)	-100.00 to 100.00%	Y	Y	0.00
o83	(Bias base point)	0.00 to 100.00%	Y	Y	0.00
o85	(Display unit)	Same as J105. (Note that the data setting range starts with "1.")	N	Y	2
o86	(Maximum scale)	-999 to 0.00 to 9990	N	Y	100
o87	(Minimum scale)	-999 to 0.00 to 9990	N	Y	0.00
o90	Terminal [Ao/CS2] Function (Function)	Same as F31.	Y	Y	0
o91	(Output gain)	0 to 300%	Y	Y	100
o93	(Polarity)	0: Bipolar 1: Unipolar	N	Y	1
o96	Terminal [CS/CS1] Function (Function)	Same as F31.	Y	Y	0
o97	(Output gain)	0 to 300%	Y	Y	100

Chapter 8

Names and functions of keypad components

1

LED Indicators

These indicators show the current running status of the inverter.

STATUS (green): Running state

WARN. (yellow): Light alarm state

ALARM (red): Alarm (heavy alarm) state

2

LCD Monitor

This monitor shows the following various information about the inverter according to the operation modes.

- Running status and run command source (e.g., Run/stop and rotation direction)
- Status icons (e.g., timer operation, PID operation, battery state, and password protection state)
- Operation guides for the current screen

3

Programming Keys

These keys are used to:

- Switch the operation modes between Running mode/Alarm mode and Programming mode.
- Reset the alarm states, discard the setting being configured, and cancel the screen transition according to the operation modes.
- Move the cursor to the digit of data to be modified, shift the setting item, and switch the screen.
- Call up the HELP screen for the current display state.

4

Operation Keys

These keys are used to:

- Start running the motor (in the forward/reverse direction).
- Stop the motor.



Chapter 9

Option relay Cards (OPC-G1-RY and OPC-G1-RY2)

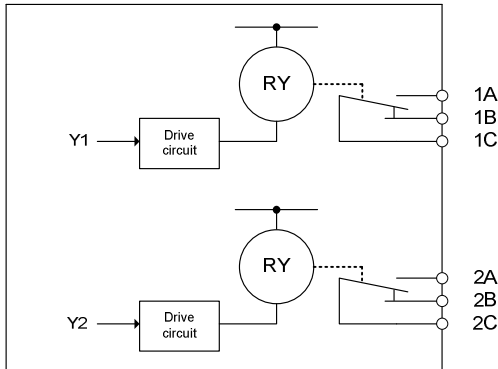

Figure 9.1 Internal Diagram OPC-G1-RY

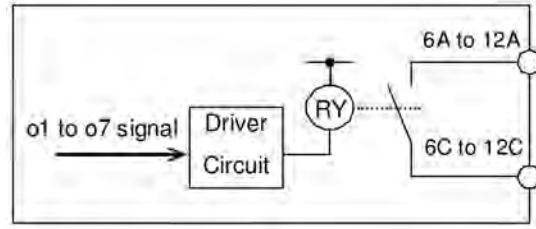

Figure 9.2 Internal Diagram OPC-G1-RY2

The relay option card OPC-G1-RY is an option to transform Y1 and Y2 (or Y3 and Y4) transistors output to a relay output.

The relay option card OPC-G1-RY2 is an option add seven additional relays (from 6 A/C to 12 A/C).

These cards are essential in order to implement the following pump control systems (for additional information check page 5):

- Mono-pump control with up to 8 line pumps (+ 1 additional pump)
- Multi-regulated pump control with 4 regulated pumps (+ 1 additional pump)

The functions that can be assigned to these relays are:

160 (1160): Sequenced start motor 1, inverter-driven	(M1_I)
161 (1161): Sequenced start motor 1, commercial-power driven	(M1_L)
162 (1162): Sequenced start motor 2, inverter-driven	(M2_I)
163 (1163): Sequenced start motor 2, commercial-power driven	(M2_L)
164 (1164): Sequenced start motor 3, inverter-driven	(M3_I)
165 (1165): Sequenced start motor 3, commercial-power driven	(M3_L)
166 (1166): Sequenced start motor 3, inverter-driven	(M4_I)
167 (1167): Sequenced start motor 4, commercial-power driven	(M4_L)
169 (1169): Sequenced start motor 5, commercial-power driven	(M5_L)
171 (1171): Sequenced start motor 6, commercial-power driven	(M6_L)
173 (1173): Sequenced start motor 7, commercial-power driven	(M7_L)
175 (1175): Sequenced start motor 8, commercial-power driven	(M8_L)

The functions codes to change the function of each relay are:

Relay 1 A/B/C	Function Code E20 and/or E22
Relay 2 A/B/C	Function Code E21 and/or E23
Relay 6 A/C	Function Code o01
Relay 7 A/C	Function Code o02
Relay 8 A/C	Function Code o03
Relay 9 A/C	Function Code o04
Relay 10 A/C	Function Code o05
Relay 11 A/C	Function Code o06
Relay 12 A/C	Function Code o07

PUMP Application Inverter.

Jaguar VXA

Pump Control Guide

First Edition, Jan 2016

IMO Precision Controls Ltd

The purpose of this guide is to provide accurate information in handling, setting up and operating of the JAGUAR VXA series of inverters for pump applications. Please feel free to send your comments regarding any errors or omissions you may have found, or any suggestions you may have for generally improving the guide.

In no event will IMO Precision Controls Ltd. be liable for any direct or indirect damages resulting from the application of the information in this manual.

IMO Precision Controls Ltd.

1000 North Circular Road, Staples Corner, London, NW2 7JP England

Phone: +44 (0)20 8452 6444 Fax: +44 (0)20 8450 2274

URL <http://www.imopc.com>
