



Motor Control Gear Technical Data



Contents

Values for Three Phase Motors	3
Contactors	4-21
Accessories	22
Contactors & Accessories: wiring	23
Contactors: dimensions	24-27
Contactors: dimensions accessories	28-31
Contactors: position of terminals	32
Thermal Overload Relays : plug in mounting	33
Thermal Overload Relays: separate mounting	34
Thermal Overload Relays: tripping characteristics	35-38
Thermal Overload Relays: special version	39
Thermal Overload Relays: data	40
Thermal Overload Relays: dimensions	41-43

Approximate Values for three-phase Motors



Motor Full Load Currents

Approximate values of motor F.L.C. and minimum "slow blow" respectively "gL" short-circuit fuse

Motor rating		Range according to BS for 415V			220-230V Motor			240V Motor			380-400V Motor			415V Motor			500V-Motor			660-690V Motor					
					F.L.C.	D.O.L.	YD	F.L.C.	D.O.L.	YD	F.L.C.	D.O.L.	YD	F.L.C.	D.O.L.	YD	F.L.C.	D.O.L.	YD	F.L.C.	D.O.L.	YD	F.L.C.	D.O.L.	YD
kW	PS-hp	hp	cosφ	%																					
0.06	0.08	-	0.7	59	0.38	1	1	0.35	1	1	0.22	1	1	-	-	-	0.16	1	1	-	-	-			
0.09	0.12	-	0.7	60	0.55	2	2	0.5	2	2	0.33	1	1	-	-	-	0.24	1	1	-	-	-			
0.12	0.16	-	0.7	61	0.76	2	2	0.68	2	2	0.42	2	2	-	-	-	0.33	1	1	-	-	-			
0.18	0.24	-	0.7	61	1.1	2	2	1	2	2	0.64	2	2	-	-	-	0.46	1	1	-	-	-			

The motor F.L.C. be valid for standard internal and surface cooled three-pole motors with 1500 min⁻¹. The fuses values be valid for the motor F.L.C. shown in the table and D.O.L.-start: starting current max. 6x motor F.L.C., starting time max. 5s; star-delta-start: starting current max. 2x motor F.L.C., starting time max. 15s. For motors with higher F.L.C., higher starting current and / or longer starting time, larger short-circuit fuses are required. The maximum admissible value is dependent on the switchgear respectively thermal overload relay.

Approximate values of motor F.L.C. according to CSA and UL

Motor rating hp	Motor F.L.C. at 110-120V			Motor F.L.C. at 220-240V1)			Motor F.L.C. at 440-480V			Motor F.L.C. at 550-600V		
	1-phase	2-phase	3-phase	1-phase	2-phase	3-phase	1-phase	2-phase	3-phase	1-phase	2-phase	3-phase
1/2	9.8	4.0	4.4	4.9	2.0	2.2	2.5	1.0	1.1	2.0	0.8	0.9
3/4	13.8	4.8	6.4	6.9	2.4	3.2	3.5	1.2	1.6	2.8	1.0	1.3
1	16.0	6.4	8.4	8.0	3.2	4.2	4.0	1.6	2.1	3.2	1.3	1.7
1-1/2	20.0	9.0	12.0	10.0	4.5	6.0	5.0	2.3	3.0	4.0	1.8	2.4

1) Determine the motor current for 200V and 208V by increasing the values for 220-240V at 200V about 15% and for 208V about 10%.

Contactors

Data according to IEC 947-4-1, EN 60947-4-1, VDE 0660

Main Contacts		Type	MC10	MC14	MC18	MC22	MC24	MC32	MC40	MC50	MC62	MC74
Rated insulation voltage U_i ¹⁾		V AC	690	690	690	690	690	690	690	690	690	690
Making capacity I_{eff} at $U_e = 690V$ AC		A	200	200	200	200	400	500	500	700	900	900
Breaking capacity I_{br} 400V AC		A	180	180	200	200	380	400	400	600	800	800
MB09 to MC22 $\cos\varphi = 0,65$		500V~	150	150	180	180	300	370	370	500	700	700
MC24 to K3-1200 $\cos\varphi = 0,35$		690V~	100	100	150	150	260	340	340	400	500	500
		1000V~	-	-	-	-	-	-	-	-	-	-
Utilization category AC1 Switching of resistive load												
Rated operational current $I_e (=I_{in})$ at 40°C, open		A	25	25	32	32	50	65	80	110	120	130
Rated operational power		220V	9,5	9,5	12,2	12,2	19,0	24,7	30,4	41,9	45,7	49,5
of three-phase resistive loads		230V	9,9	9,9	12,7	12,7	19,9	25,9	31,8	43,8	47,7	51,7
50-60Hz, $\cos\varphi = 1$		240V	10,4	10,4	13,3	13,3	20,8	27,0	33,2	45,7	49,8	54,0
		380V	16,4	16,4	21,0	21,0	32,9	42,7	52,6	72,3	78,9	85,5
		400V	17,3	17,3	22,1	22,1	34,6	45,0	55,4	76,1	83,0	90,0
		415V	17,9	17,9	23,0	23,0	35,9	46,7	57,4	79,0	86,2	93,3
		440V	19,0	19,0	24,4	24,4	38,1	49,5	60,9	83,7	91,3	99,0
		500V	21,6	21,6	27,7	27,7	43,3	56,2	69,2	95,2	103,8	112,5
		660V	28,5	28,5	36,5	36,5	57,1	74,2	91,3	125,6	137,0	148,4
		690V	29,8	29,8	38,2	38,2	59,7	77,6	95,5	131,3	143,2	155,2
		1000V	-	-	-	-	-	-	-	-	-	-
Rated operational current $I_e (=I_{in})$ at 60°C, enclosed		A	25	25	32	32	40	55	65	90	100	110
Rated operational power		220V	9,5	9,5	12,2	12,2	15,2	20,9	24,7	34,3	38,1	41,9
of three-phase resistive loads		230V	9,9	9,9	12,7	12,7	15,9	21,9	25,9	35,8	39,8	43,8
50-60Hz, $\cos\varphi = 1$		240V	10,4	10,4	13,3	13,3	16,6	22,8	27,0	37,4	41,5	45,7
		380V	16,4	16,4	21,0	21,0	26,3	36,2	42,7	59,2	65,7	72,3
		400V	17,3	17,3	22,1	22,1	27,7	38,1	45,0	62,3	69,2	76,1
		415V	17,9	17,9	23,0	23,0	28,7	39,5	46,7	64,6	71,8	79,0
		440V	19,0	19,0	24,4	24,4	30,4	41,9	49,5	68,5	76,1	83,7
		500V	21,6	21,6	27,7	27,7	34,6	47,6	56,2	77,9	86,5	95,2
		660V	28,5	28,5	36,5	36,5	45,7	62,8	74,2	102,8	114,2	125,6
		690V	29,8	29,8	38,2	38,2	47,7	65,7	77,6	107,4	119,4	131,3
		1000V	-	-	-	-	-	-	-	-	-	-
Minimum cross-section of conductor at load with $I_e (=I_{in})$		mm	4	4	6	6	10	16	25	35	50	50
Utilization category AC2 and AC3 Switching of three-phase motors												
Rated operational current I_e open and enclosed		220V	12	15	18	22	24	30	40	50	63	74
		230V	11,5	14,5	18	22	24	30	40	50	62	74
		240V	11	14	18	22	24	32	40	50	62	74
380-400V		A	10	14	18	22	24	32	40	50	62	74
		415V	9	14	18	22	23	30	40	50	62	74
		440V	9	14	18	22	23	30	40	50	62	74
		500V	7	9	9	9	17,5	21	21	33	42	42
		660-690V	6,5	8,5	8,5	8,5	17	20	20	31	40	40
		1000V	-	-	-	-	-	-	-	-	-	-
Rated operational power of three-phase motors 50-60Hz		220-230V	3	4	5	6	6	8,5	11	12,5	18,5	22
		240V	3	4	5	7	7	9	11,5	13,5	19	23
		380-400V	4	5,5	7,5	11	11	15	18,5	22	30	37
		415V	4,5	6	8,5	12	12	16	20	24	33	40
		440V	4,5	6	8,5	12	12	16	20	24	33	40
		500V	5,5	7,5	10	10	15	18,5	18,5	30	37	45
		660-690V	5,5	7,5	10	10	15	18,5	18,5	30	37	45
		1000V	-	-	-	-	-	-	-	-	-	-

1) Suitable at 690V for: earthed-neutral systems, overvoltage category I to IV, pollution degree 3 (standard-industry): $U_{imp} = 8kV$.
Data for other conditions on request.

Contactors

Data according to IEC 947-4-1, EN 60947-4-1, VDE 0660

Main Contacts	Type	MC10	MC14	MC18	MC22	MC24	MC32	MC40	MC50	MC62	MC74	
Utilization category AC4												
Switching of squirrel cage motors, inching												
Rated operational current I_n open and enclosed	220V	A	12	15	18	18	24	30	40	50	63	63
	230V	A	11,5	14,5	18	18	24	30	40	50	62	62
	240V	A	11	14	18	18	24	32	40	50	62	62
380-400V	A	10	14	18	18	24	32	40	50	62	62	
415V	A	9	14	18	18	23	30	37	45	60	60	
440V	A	9	14	18	18	23	30	37	45	55	55	
500V	A	9	12	16	16	17,5	21	21	33	42	42	
660V	A	7	9	9	9	17	20	20	31	40	40	
690V	A	6,5	8,5	8,5	8,5	17	20	20	31	40	40	
1000V	A	-	-	-	-	-	-	-	-	-	-	
Rated operational power of three-phase motors 50-60Hz	220-230V	kW	3	4	5	5	6	8,5	11	12,5	18,5	18,5
	240V	kW	3	4	5	5	7	9	11,5	13,5	19	19
	380-400V	kW	4	5,5	7,5	7,5	11	15	18,5	22	30	30
	415V	kW	4,5	6	8,5	8,5	12	16	20	24	33	33
	440V	kW	4,5	6	8,5	8,5	12	16	20	24	33	33
	500V	kW	5,5	7,5	10	10	15	18,5	18,5	30	37	37
	660-690V	kW	5,5	7,5	10	10	15	18,5	18,5	30	37	37
	1000V	kW	-	-	-	-	-	-	-	-	-	-
Utilization category AC5a												
Switching of gas discharge lamps												
Rated operational current I_n per pole at 220/230V												
Fluorescent lamps, uncompensated and serial compensated												
	A	20	20	25	25	40	52	64	88	96	104	
	A	7	9	9	9	18	22	22	30	40	45	
	A	22,5	22,5	28	28	45	58	72	98	108	117	
Metal halide lamps ₁₎ , uncompensated												
	A	12	15	19	19	30	39	48	66	72	78	
	A	7	9	9	9	18	22	22	30	40	45	
Mercury-vapour lamps ₂₎ , uncompensated												
	A	22,5	25	28	28	45	58	72	99	108	117	
	A	7	9	9	9	18	22	22	30	40	45	
Mixed light lamps ₃₎												
	A	20	20	25	25	40	52	64	88	96	104	
Utilization category AC5b												
Switching of incandescent lamps₄₎												
Rated operational current I_n per pole at 220/230V												
	A	12,5	12,5	12,5	12,5	25	31	31	43	56	56	

1) Metal halide lamps and sodium-vapour lamps (high- and low-pressure lamps)

2) High-pressure lamps

3) Blended lamps, containing a mercury high-pressure unit and a tungsten helix in a fluorescent glass bulb (daylight lamps)

4) Current inrush approx. $16 \times I_n$

5) With central compensation pay attention to the current inrush (capacitor switching contactors)

Contactors

Data according to IEC 947-4-1, EN 60947-4-1, VDE 0660

Type	K85	K110	K3-150	K3-175	K3-200	K3-315	K3-450	K3-550	K3-700	K3-860	K3-1000	K3-1200
A	85	98	55	63	85	120	150	180	230	280	340	400
A	85	98	55	63	85	120	150	180	230	280	340	400
A	85	98	55	63	85	120	150	180	230	280	340	400
A	85	85	55	63	85	120	150	180	230	280	340	400
A	85	85	-	-	-	-	-	-	-	-	-	-
A	85	85	-	-	-	-	-	-	-	-	-	-
A	85	85	-	-	-	-	-	-	-	-	-	-
A	60	60	-	-	-	-	-	-	-	-	-	-
A	57,5	57,5	-	-	-	-	-	-	-	-	-	-
A	-	-	-	-	-	-	-	-	-	-	-	-
kW	25	30	15	18,5	25	37	45	51	68	80	110	132
kW	27	32	15,5	19	26	38	47	53	71	83	115	137
kW	45	45	25	30	45	63	75	90	120	150	185	220
kW	49	49	25	33	45	65	80	100	132	160	200	230
kW	49	49	30	34	48	67	85	100	132	160	200	230
kW	55	55	25	30	55	75	100	110	150	185	220	257
kW	55	55	25	30	55	75	100	110	150	185	220	257
kW	-	-	-	-	-	-	-	-	-	-	-	-
A	100	120	120	140	180	280	360	450	570	700	850	1000
A	55	70	85	100	120	200	300	360	460	550	660	800
A	112	144	120	140	180	280	360	450	570	700	850	1000
A	85	90	95	110	140	230	300	380	490	610	750	890
A	55	70	75	85	110	170	260	300	400	480	580	700
A	112	144	120	140	180	280	360	450	570	700	850	1000
A	55	70	75	85	110	170	260	300	400	480	580	700
A	100	120	100	120	160	250	320	400	500	600	700	800
A	69	75	100	120	160	220	260	315	440	500	560	630

Contactors

Data according to IEC 947-4-1, EN 60947-4-1, VDE 0660

Main Contacts			Type	MC10	MC14	MC18	MC22	MC24	MC32	MC40	MC50	MC62	MC74
Utilization category AC6a													
Transformer primary switching													
at inrush													
Rated operational current I_n													
	400V	n A		30 4,5	30 5,5	30 7,5	30 7,5	30 10,5	30 13,5	30 13,5	30 20	30 27	30 33
Rated operational power dependent on inrush n													
	220-230V	kVA		1,8	2,2	3	3	4,2	5,4	5,4	8	10,7	13
	240V	kVA		1,9	2,3	3,1	3,1	4,3	5,6	5,6	8,3	11,2	13,5
	380-400V	kVA		3,1	3,8	5,2	5,2	7,3	9,3	9,3	13,5	18,5	22,5
For different inrush-factors x use the following formula: $P_x = P_n * (n/x)$													
	415-440V	kVA		3,4	4,2	5,7	5,7	8	10,2	10,2	15	20,5	25
	500V	kVA		3,9	4,8	6,5	6,5	9	11,5	11,5	17	23	28
	660-690V	kVA		5,4	6,5	9	9	12,5	16	16	24	32	39
Utilization category AC6b													
Switching of three-phase capacitor banks													
Maximum inrush current (peak value) as multiple k of the capacitor rated current													
Rated operational current I_n													
	500V	k A		35 8	25 12	20 15,5	20 15,5	25 23	25 32	25 32	25 45	25 60	20 70
Rated operational power ($\sin\varphi \rightarrow 1$)													
	220-230V	kVAr		3	4,5	6	6	8,5	12	12	17	24	28
	240V	kVAr		3,5	5	6,5	6,5	9,5	13	13	18,5	25	29
	380-400V	kVAr		5	7,5	10	10	15	20	20	29	39	46
For different multiples x use the following formula: $P_x = P_k * (k/x)$													
	415-440V	kVAr		5,5	8	11	11	16	22	22	32	43	50
	500V	kVAr		7	10	13	13	20	26	26	39	50	58
	660-690V	kVAr		7	10	13	13	20	26	26	40	50	58
Switching of detuned capacitors													
Rated operational current I_n													
	690V	A		8	13	18	20	28	35	42	48	72	105 ¹⁾
Rated operational power													
	220-230V	kVAr		2,9	5	7	7,5	11	14	16	20	28	33
	240V	kVAr		3,1	5,4	7	8	11	14	17	20	28	36
	380-400V	kVAr		5	9	12,5	13	20	25	27,5	33,3	50	75 ¹⁾
	415-440V	kVAr		5,5	9,5	13	14	22	27	30	36	53	75 ¹⁾
	500V	kVAr		6	11	15	17	25	30	36	40	60	75
	660-690V	kVAr		8	15	20	22	33	41	48	55	82	100
Utilization category DC1													
Switching of resistive load													
Time constant $L/R \leq 1ms$													
Rated operational current I_n													
	1 pole	24V 60V 110V 220V	A A A A	20 20 6 0,8	25 25 6 0,8	32 32 6 0,8	32 32 6 0,8	50 50 10 1,4	65 65 10 1,4	80 80 10 1,4	110 110 12 1,4	120 120 12 1,4	130 130 12 1,4
	3 poles in series	24V 60V 110V 220V	A A A A	20 20 20 16	25 25 25 20	32 32 32 20	32 32 32 20	50 50 50 30	65 65 65 35	80 80 80 35	110 110 110 63	120 120 120 80	130 130 130 80
Utilization category DC3 and DC5													
Switching of shunt motors and series motors													
Time constant $L/R \leq 15ms$													
Rated operational current I_n													
	1 pole	24V 60V 110V 220V	A A A A	20 6 1,2 0,2	25 6 1,2 0,2	32 6 1,2 0,2	32 6 1,2 0,2	50 30 1,8 0,2	65 30 1,8 0,2	80 30 1,8 0,2	110 60 1,8 0,25	120 60 1,8 0,25	130 60 1,8 0,25
	3 poles in series	24V 60V 110V 220V	A A A A	20 20 20 2,5	25 25 20 2,5	32 32 20 2,5	32 32 20 2,5	50 40 40 4	65 40 40 4	80 40 40 4	110 80 80 5	120 80 80 5	130 80 80 5

Contactors

Data according to IEC 947-4-1, EN 60947-4-1, VDE 0660

Main Contacts			Type	MC10	MC14	MC18	MC22	MC24	MC32	MC40	MC50	MC62	MC74
Maximum ambient temperature													
Operation	open	°C						-40 to +60 (+90) ¹⁾					
	enclosed	°C						-40 to +40					
with thermal overload relay	open	°C						-25 to +60					
	enclosed	°C						-25 to +40					
Storage		°C						-50 to +90					
Short circuit protection													
for contactors without thermal overload relay													
Coordination-type "1" according to IEC 947-4-1													
Contact welding without hazard of persons													
max. fuse size	gL (gG)	A	63	63	63	63	80	80	80	160	160	160	160
Coordination-type "2" according to IEC 947-4-1													
Light contact welding accepted													
max. fuse size	gL (gG)	A	25	35	35	35	50	50	50	100	125	125	125
Contact welding not accepted													
max. fuse size	gL (gG)	A	16	16	16	16	25	35	35	50	63	63	63
For contactors with thermal overload relay the device with the smaller admissible backup fuse (contactor or thermal overload relay) determines the fuse size.													
Cable cross-sections													
for contactors without thermal overload relay													
main connector	solid or stranded	mm ²		0,75 - 6				1,5 - 25			4 - 50		
	flexible	mm ²		1 - 4				2,5 - 16			10 - 35		
	flexible with multicore cable end	mm ²		0,75 - 4				1,5 - 16			6 - 35		
Cables per clamp				2				1			1		
	solid or stranded	mm ²		6+(1-6) / 4+(0,75-4) 2,5+(0,75-2,5) / 1,5+(0,75-1,5)				16+(2,5-6) / 10+(4-10) 6+(4-6) / 4+(2,5-4)			50+4 / 35+6 / 25+(6-16) 16+(6-16) / 10+(6-16)		
	flexible	mm ²		6+(1,5-6) / 4+(1-4) 2,5+(0,75-2,5) / 1,5+(0,75-1,5)				16+(2,5-6) / 10+(4-10) 6+(4-6) / 4+(2,5-4)			50+(4-10) / 35+(4-16) 25+(4-25) / 16+(4-16)		
Cables per clamp				2				2			2		
main connector	solid	AWG		18 - 10				16 - 10			12 - 10		
	flexible	AWG		18 - 10				14 - 4			10 - 0		
Cables per clamp				2				1			1		
	solid	AWG		10+(16-10) / 12+(18-12) 14+(18-14) / 16+(18-16)				10+(16-10) / 12+(18-12) 14+(18-14) / 16+(18-16)			10+(12-10) / 12+12		
	flexible	AWG		10+(14-10) / 12+(18-12) 14+(18-14) / 16+(18-16)				4+(18-12) / 6+(18-8) 8+(18-8) / 10+(18-12)			1+(12-10) / 2+(8-12) 3+(12-8) / 4+(10-6)		
Cables per clamp				2				2			2		
Frequency of operations z													
Contactors without thermal overload relay													
	without load	1/h	10000	10000	10000	10000	7000	7000	7000	7000	7000	7000	7000
	AC3, I _b	1/h	600	600	600	600	600	600	600	600	400	400	400
	AC4, I _b	1/h	120	120	120	120	120	120	120	120	120	120	120
	DC3, I _b	1/h	600	600	600	600	600	600	600	600	400	400	400
Mechanical life													
AC operated	S x 10 ⁶		10	10	10	10	10	10	10	10	10	10	10
DC operated	S x 10 ⁶		10	10	10	10	10	10	10	10	10	10	10
Short time current													
	10s-current	A	96	120	144	.	184	240	296	360	504	.	.
Power loss per pole													
	at I _b /AC3 400V	W	0,21	0,26	0,4	.	0,63	1,1	1,7	1,8	3,6	.	.
Resistance to shock acc. to IEC 68-2-27													
Shock time 20ms sine-wave													
	NO	g	10	10	10	10	8	8	8	8	8	8	8
	NC	g	6	6	6	6	5	5	5	-	-	-	-

1) With reduced control voltage range 0,9 up to 1,0 x U_c and with reduced rated current I_b/AC1 according to I_b/AC3

2) Maximum cable cross-section with prepared conductor

Contactors

Data according to IEC 947-4-1, EN 60947-4-1, VDE 0660

Type	K85	K110	K3-150	K3-175	K3-200	K3-315	K3-450	K3-550	K3-700	K3-860	K3-1000	K3-1200	
°C	-40 to +60 (+90) ¹⁾								-25 to +55 (+70) ³⁾				
°C	-40 to +40								-25 to +40				
°C	-25 to +60								-25 to +55				
°C	-25 to +40								-25 to +40				
°C	-50 to +90								-55 to +80				
A	250	250	250	315	400	500	630	630	800	1000	1000	1250	
A	160	200	200	250	315	400	-	-	-	-	-	-	
A	100	125	160	200	250	315	400	-	-	-	-	-	
mm ²	10 - 70 ²⁾	10 - 70 ²⁾	95	120	185	busbar 2x(30x5)	busbar 2x(40x5)	busbar 2x(50x5)	busbar 2x(60x5)	busbar 2x(60x6)	busbar 2x(60x6)	busbar 2x(60x8)	
mm ²	6 - 50 ²⁾	16 - 50 ²⁾	screw	screw	screw	screw	screw	screw	screw	screw	screws	screws	
mm ²	10 - 35	10 - 35	M8	M8	M8	M10	M10	M12	M12	M14	2 x M12	2 x M12	
	1	1	-	-	-	-	-	-	-	-	-	-	
AWG	10	10											
AWG	6 - 0	6 - 0											
	1	1											
1/h	3000	3000	1200	1200	1200	1200	1200	1200	1200	1200	300	300	
1/h	300	300	-	-	-	-	-	-	-	-	-	-	
1/h	120	120	-	-	-	-	-	-	-	-	-	-	
1/h	300	300	-	-	-	-	-	-	-	-	-	-	
S x 10 ⁶	5	5	10	10	8	5	5	5	5	5	5 ⁴⁾	5 ⁴⁾	
S x 10 ⁶	5	5	10	10	8	5	5	5	5	5	5 ⁴⁾	5 ⁴⁾	
A	680	880	1200	1400	1800	2600	3600	4400	5600	6900	8000	9600	
W	4,3	6,0	11,2	10,7	8	15,9	26,3	33,3	49	59,2	60	72	
g	7	7	-	-	-	-	-	-	-	-	-	-	
g	5	5	-	-	-	-	-	-	-	-	-	-	

1) With reduced control voltage range 0,9 up to 1,0 x U_c and with reduced rated current I_e/AC1 according to I_e/AC3

2) Maximum cable cross-section with prepared conductor

3) With reduced control voltage range 1,0 x U_c and with reduced rated current I_e/AC1 according to I_e/AC3

4) After each 1x10⁶ operations magnetic core and built-in auxiliary contact block must be changed

Contactors

Data according to IEC 947-4-1, EN 60947-4-1, VDE 0660

Auxiliary Contacts			Type	MC10	MC14	MC18	MC22	MC24	MC32	MC40	MC50	MC62	MC74
Rated insulation voltage U_i ¹⁾			V~	690	690	690	690	-	-	-	-	-	-
Thermal rated current I_n to 690V													
Ambient temperature			40°C A	16	16	16	16	-	-	-	-	-	-
			60°C A	12	12	12	12	-	-	-	-	-	-
Utilization category AC15													
Rated operational current I_n			220-240V A	12	12	12	12	-	-	-	-	-	-
			380-415V A	4	4	4	4	-	-	-	-	-	-
			440V A	4	4	4	4	-	-	-	-	-	-
			500V A	3	3	3	3	-	-	-	-	-	-
			660-690V A	1	1	1	1	-	-	-	-	-	-
Utilization category DC13													
Rated operational current I_n			60V A	8	8	8	8	-	-	-	-	-	-
			110V A	1	1	1	1	-	-	-	-	-	-
			220V A	0,1	0,1	0,1	0,1	-	-	-	-	-	-
Short circuit protection													
short-circuit current 1kA, contact welding not accepted max. fuse size			gL (gG) A	25	25	25	25	-	-	-	-	-	-
For contactors with thermal overload relay the device with the smaller admissible control fuse (contactor or thermal overload relay) determines the fuse.													
Control Circuit													
Power consumption of coils													
AC operated			inrush VA	33-45			90-115			140-165			
			sealed VA	7-10			9-13			13-18			
			W	2,6-3			2,7-4			5,4-7			
DC operated			inrush W	75			140			200			
w. econ. circuit up to 24/above 24V sealed			W	2 / 7			2			6			
Operation range of coils													
in multiples of control voltage U_c			AC operated	0,85-1,1			0,85-1,1			0,85-1,1			
			DC operated	0,8-1,1			0,8-1,1			0,8-1,1			
Switching time													
at control voltage $U_c \pm 10\%$ ²⁾³⁾													
AC operated			make time ms	8-16			10-25			12-28			
			release time ms	5-13			8-15			8-15			
			arc duration ms	10-15			10-15			10-15			
DC operated			make time ms	8-12			10-20			12-23			
with AC magnet system			release time ms	8-13			10-15			10-18			
			arc duration ms	10-15			10-15			10-15			
Cable cross-section													
Auxiliary connector			solid mm ²	0,75-6			-			-			
			flexible mm ²	1-4			-			-			
			flexible with multicore cable end mm ²	0,75-4			-			-			
Magnet coil			solid mm ²	0,75-2,5			0,75-2,5			0,75-2,5			
			flexible mm ²	0,5-2,5			0,5-2,5			0,5-2,5			
			flexible with multicore cable end mm ²	0,5-1,5			0,5-1,5			0,5-1,5			
Clamps per pole				2			2			2			
Auxiliary connector			solid AWG	18 - 10-			-			-			
			flexible AWG	18 - 10			-			-			
Magnet coil			solid AWG	14 - 12			14 - 12			14 - 12			
			flexible AWG	18 - 12			18 - 12			18 - 12			
Clamps per pole				2			2			2			

1) Suitable for: earthed-neutral systems, overvoltage category I to IV, pollution degree 3 (standard-industry): $U_{imp} = 8kV$. Data for other conditions on request

2) Total breaking time = release time + arc duration

3) Values for delay of the release time of the make contact and the make time of the break contact will be increased, if magnet coils are protected against voltage peaks (varistor, RC-unit, diode-unit)

Contactors

Data according to IEC 947-4-1, EN 60947-4-1, VDE 0660

Type	K85	K110	K3-150	K3-175	K3-200	K3-315	K3-450	K3-550	K3-700	K3-860	K3-1000	K3-1200
V~	690	690	690	690	690	690	690	690	690	690	690	690
A	16	16	10	10	10	10	10	10	10	10	10	10
A	12	12	-	-	-	-	-	-	-	-	-	-
A	12	12	3	3	3	3	3	3	3	3	3	3
A	6	6	2	2	2	2	2	2	2	2	2	2
A	6	6	1,5	1,5	1,5	1,5	1,5	1,5	1,5	1,5	1,5	1,5
A	4	4	1,5	1,5	1,5	1,5	1,5	1,5	1,5	1,5	1,5	1,5
A	2	2	1	1	1	1	1	1	1	1	1	1
A	8	8	-	-	-	-	-	-	-	-	-	-
A	1	1	0,5	0,5	1	1	1	1	1	1	1	1
A	0,1	0,1	0,2	0,2	0,5	0,5	0,5	0,5	0,5	0,5	0,5	0,5
A	25	25	10	10	10	10	10	10	10	10	10	10
VA	280-350	350-420	550	550	1100	2300	800-950	800-950	1350-1600	1350-1600	2400	2400
VA	16-23	23-29	120	120	66	120	9-11	9-11	21-25	21-25	70	70
W	4-6	6-7,3	-	-	-	-	-	-	-	-	-	-
W	170	320	160	160	530	580	700-850	700-850	1300-1550	1300-1550	2100	2100
W	2	4	5	5	21	22	8-10	8-10	18-22	18-22	60	60
	0,85-1,1		0,85-1,1	0,85-1,1	0,85-1,1	0,85-1,1		0,85-1,1			0,85-1,1	
	0,8-1,1		0,85-1,1	0,85-1,1	0,85-1,1	0,85-1,1		0,85-1,1			0,85-1,1	
ms	13-30		12-30	12-30	30-40	25-50		50-100			50-100	
ms	8-15		15-40	15-40	15-45	15-30		150-200 / 500-1000			25-50	
ms	10-15		-	-	-	-		-			-	
ms	20-30		-	-	-	-		-			-	
ms	10-18		-	-	-	-		-			-	
ms	10-15		-	-	-	-		-			-	
mm	0,75-2,5			0,75-2,5				0,75-2,5			0,75-2,5	
mm	0,75-2,5			0,75-2,5				0,75-2,5			0,75-2,5	
mm	0,5-1,5			-				-			-	
mm	0,75-2,5			1-2,5				1-2,5			1-2,5	
mm	0,5-2,5			1-2,5				1-2,5			1-2,5	
mm	0,5-1,5			-				-			-	
	2			2				2			2	
AWG	14 - 12			16 - 12				16 - 12			16 - 12	
AWG	18 - 12			16 - 12				16 - 12			16 - 12	
AWG	14 - 12			16 - 12				16 - 12			16 - 12	
AWG	18 - 12			16 - 12				16 - 12			16 - 12	
	2			2				2			2	

Contactors

Data according to IEC 947-4-1, EN 60947-4-1, VDE 0660

Main Contacts		Type	K(G)2-09	K(G)2-12	K(G)2-16	K2-23	K2-30	K2-37	K2-45	K2-60
Rated insulation voltage U_i ¹⁾		V AC	690	690	690	690	690	690	690	690
Making capacity I_{mf} at $U_e = 690V$ AC		A	200	200	200	400	500	500	700	900
Breaking capacity I_{bf}		400V AC A	180	180	200	380	400	400	600	800
K1-09 to K2-16 $\cos\varphi = 0,65$		500V AC A	150	150	180	300	370	370	500	700
K2-23 to K3-1200 $\cos\varphi = 0,35$		690V AC A	100	100	150	260	340	340	400	500
		1000V AC A	-	-	-	-	-	-	-	-
Utilization category AC1										
Switching of resistive load										
Rated operational current $I_e (=I_{th})$ at 40°C, open		A	25	25	25	45	50	50	80	100
Rated operational power		220V kW	9,5	9,5	9,5	17	19	19	30	38
of three-phase resistive loads		230V kW	10	10	10	18	20	20	31,5	40
50-60Hz, $\cos\varphi = 1$		240V kW	10,5	10,5	10,5	18,5	20,5	20,5	33	41
		380V kW	16,5	16,5	16,5	29,5	33	33	52	65
		400V kW	17,5	17,5	17,5	31	34,5	34,5	55	69
		415V kW	18	18	18	32	36	36	57	71
		440V kW	19	19	19	34	38	38	61	76
		500V kW	21,5	21,5	21,5	39	43	43	69	86
		660V kW	28,5	28,5	28,5	51	57	57	91	114
		690V kW	29,5	29,5	29,5	53,5	60	60	95	119
Rated operational current $I_e (=I_{th})$ at 60°C, enclosed		A	20	25	25	35	40	40	63	80
Rated operational power		220V kW	7,5	9,5	9,5	13	15	15	24	30
of three-phase resistive loads		230V kW	8	10	10	13,5	16	16	25	31,5
50-60Hz, $\cos\varphi = 1$		240V kW	8	10,5	10,5	14,5	16,5	16,5	26	33
		380V kW	13	16,5	16,5	23	26	26	41	52
		400V kW	13,5	17,5	17,5	24	27,5	27,5	43	55
		415V kW	14	18	18	25	28,5	28,5	45	57
		440V kW	15	19	19	26,5	30	30	48	61
		500V kW	17	21,5	21,5	30	34	34	54	69
		660V kW	22,5	28,5	28,5	40	45	45	72	91
		690V kW	23,5	29,5	29,5	42	48	48	75	95
Minimum cross-section of conductor at load with $I_e (=I_{th})$		mm	4	4	4	10	10	10	25	35
Utilization category AC2 and AC3										
Switching of three-phase motors										
Rated operational current I_e open and enclosed		220V A	12	15	18	23	30	37	45	63
		230V A	11,5	14,5	17,5	23	30	37	45	61
		240V A	11	14	17	23	30	37	45	60
380-400V		A	10	12	16	23	30	37	45	60
415-440V		A	9	12	16	23	30	37	45	60
500V		A	9	12	16	23	30	30	45	55
		660V A	7	9	9	17,5	21	21	33	42
		690V A	6,5	8,5	8,5	17	20	20	31	40
Rated operational power of three-phase motors 50-60Hz		220-230V kW	3	4	5	6	8,5	11	12,5	18,5
		240V kW	3	4	5	7	9	11,5	13,5	19
		380-400V kW	4	5,5	7,5	11	15	18,5	22	30
		415V kW	4,5	6	8,5	12	16	20	24	33
		440V kW	4,5	6	8,5	12	16	20	24	33
		500V kW	5,5	7,5	10	15	18,5	18,5	30	37
		660-690V kW	5,5	7,5	7,5	15	18,5	18,5	30	37

1) Suitable at 690V for: earthed-neutral systems, overvoltage category I to IV, pollution degree 3 (standard-industry): $U_{imp} = 8kV$.
Data for other conditions on request.

Contactors

Data according to IEC 947-4-1, EN 60947-4-1, VDE 0660

Main Contacts			Type	K(G)2-09	K(G)2-12	K(G)2-16	K2-23	K2-30	K2-37	K2-45	K2-60
Utilization category AC4											
Switching of squirrel cage motors, inching											
Rated operational current I_n open and enclosed	220V	A	12	15	16	23	30	37	45	63	
	230V	A	11,5	14,5	16	23	30	37	45	61	
	240V	A	11	14	16	23	30	37	45	60	
	380-400V	A	10	12	16	23	30	37	45	60	
	415V	A	9	12	16	21	28	37	45	60	
	440V	A	9	12	16	21	28	37	45	60	
	500V	A	9	12	16	17	23	23	45	55	
	660V	A	7	9	9	13	17	17	33	42	
	690V	A	6,5	8,5	8,5	12,5	16,5	16,5	31	40	
Rated operational power of three-phase motors 50-60Hz	220-230V	kW	3	4	5	6	8,5	11	12,5	18,5	
	240V	kW	3	4	5	7	9	11,5	13,5	19	
	380-400V	kW	4	5,5	7,5	11	15	18,5	22	30	
	415-440V	kW	4,5	6	8,5	11	15	20	24	33	
	500V	kW	5,5	7,5	10	11	15	15	30	37	
	660-690V	kW	5,5	7,5	7,5	11	15	15	30	37	
Utilization category AC5a											
Switching of gas discharge lamps											
Rated operational current I_n per pole at 220/230V											
Fluorescent lamps, uncompensated		A	20	20	20	35	40	40	65	85	
Fluorescent lamps, compensated		A	7	9	9	18	22	22	30	40	
Fluorescent lamps, dual-connection		A	22,5	22,5	22,5	41	45	45	72	90	
Metal-vapour lamps ¹⁾ , uncompensated		A	12	15	15	28	30	30	50	62	
Metal-vapour lamps ¹⁾ , compensated		A	7	9	9	18	22	22	30	40	
Mercury-vapour lamps ²⁾ , uncompensated	A	22,5	25	25	41	45	45	72	90		
Mercury-vapour lamps ²⁾ , compensated	A		7	9	9	18	22	22	30	40	
Mixed light lamps ³⁾		A	20	20	20	35	40	40	65	85	
Utilization category AC5b											
Switching of incandescent lamps⁴⁾											
Rated operational current I_n per pole at 220/230V											
		A	12,5	12,5	12,5	25	31	31	43	56	
Utilization category AC6a											
Transformer primary switching at inrush											
Rated operational current I_n	400V	A	30	30	30	30	30	30	30	30	
		A	4,5	5,5	7,5	10,5	13,5	13,5	20	27	
Rated operational power dependent on inrush n	220-230V	kVA	1,8	2,2	3	4,2	5,4	5,4	8	10,7	
	240V	kVA	1,9	2,3	3,1	4,3	5,6	5,6	8,3	11,2	
	380-400V	kVA	3,1	3,8	5,2	7,3	9,3	9,3	13,5	18,5	
For different inrush-factors x use the following formula: $P_x = P_n \cdot (n/x)$	415-440V	kVA	3,4	4,2	5,7	8	10,2	10,2	15	20,5	
	500V	kVA	3,9	4,8	6,5	9	11,5	11,5	17	23	
	660-690V	kVA	5,4	6,5	9	12,5	16	16	24	32	
Utilization category DC1											
Switching of resistive load											
Time constant L/R ≤ 1 ms											
Rated operational current I_n	1 pole	24V	A	20	25	25	45	50	50	80	100
		60V	A	20	25	25	45	50	50	80	100
		110V	A	6	6	6	10	10	10	12	12
		220V	A	0,8	0,8	0,8	1,4	1,4	1,4	1,4	1,4
	3 poles in series	24V	A	20	25	25	45	50	50	80	100
		60V	A	20	25	25	45	50	50	80	100
		110V	A	20	25	25	45	50	50	80	100
		220V	A	16	20	20	30	35	35	63	80

1) Metal halide lamps and sodium-vapour lamps (high- and low-pressure lamps)

2) High-pressure lamps

3) Blended lamps, containing a mercury high-pressure unit and a tungsten helix in a fluorescent glass bulb (daylight lamps)

4) Current inrush approx. $16 \times I_n$

5) With central compensation pay attention to the current inrush (capacitor switching contactors)

Contactors

Data according to IEC 947-4-1, EN 60947-4-1, VDE 0660

Main Contacts			Type	K(G)2-09	K(G)2-12	K(G)2-16	K2-23	K2-30	K2-37	K2-45	K2-60
Utilization category DC3 and DC5											
Switching of shunt motors and series motors											
Time constant L/R ≤ 15ms											
Rated operational current I _e											
1 pole			24V A	20	25	25	45	50	50	80	100
			60V A	6	6	6	30	30	30	60	60
			110V A	1,2	1,2	1,2	1,8	1,8	1,8	1,8	1,8
			220V A	0,2	0,2	0,2	0,2	0,2	0,2	0,25	0,25
3 poles in series			24V A	20	25	25	45	50	50	80	100
			60V A	20	25	25	40	40	40	80	80
			110V A	20	20	20	40	40	40	80	80
			220V A	2,5	2,5	2,5	4	4	4	5	5
Maximum ambient temperature											
Operation			open °C	-40+60 (+90) ¹⁾							
			enclosed °C								
with thermal overload relay			open °C								
			enclosed °C								
Storage			°C	-50 to +90							
Short circuit protection											
for contactors without thermal overload relay											
Coordination-type "1" according to IEC 947-4-1											
Contact welding without hazard of persons											
max. fuse size			gL (gG) A	63	63	63	80	80	80	160	160
Coordination-type "2" according to IEC 947-4-1											
Light contact welding accepted											
max. fuse size			gL (gG) A	25	35	35	50	50	50	100	125
Contact welding not accepted											
max. fuse size			gL (gG) A	16	16	16	25	35	35	50	63
For contactors with thermal overload relay the device with the smaller admissible backup fuse (contactor or thermal overload relay) determines the fuse size.											
Cable cross-sections											
for contactors without thermal overload relay											
main connector			solid or stranded mm ²	0,75 - 4			1,5-10 + 1,5-6			4 - 35 ²⁾	
			flexible mm ²	0,75 - 2,5			1,5-6 + 1,5-4			6 - 25 ²⁾	
			flexible with multicore cable end mm ²	0,5 - 2,5			1,5-6 + 1,5-4			4 - 25	
Cables per clamp				2			1+1			1	
main connector			solid AWG	14 - 10			14 - 10 + 14 - 10			10	
			flexible AWG	18 - 10			14 - 8 + 14 - 10			10 - 2	
Cables per clamp				2			1+1			1	
Frequency of operations z											
Contactors without thermal overload relay											
			without load 1/h	10000	10000	10000	7000	7000	7000	7000	7000
			AC3, I _e 1/h	600	600	600	600	600	600	400	400
			AC4, I _e 1/h	120	120	120	120	120	120	120	120
			DC3, I _e 1/h	600	600	600	600	600	600	400	400
Mechanical life											
AC operated			S x 10 ⁶	10	10	10	10	10	10	10	10
DC operated with economy resistor			S x 10 ⁶	10	10	10	10	10	10	10	10
DC solenoid operated (KG2-...)			S x 10 ⁶	50	50	50	-	-	-	-	-
Short time current											
10s-current			A	96	120	144	184	240	296	360	504
Power loss per pole											
at I _e /AC3 400V			W	0,21	0,26	0,4	0,63	1,1	1,7	1,8	3,6
Resistance to shock acc. to IEC 68-2-27											
Shock time 20ms sine-wave			NO g	10	10	10	8	8	8	8	8
			NC g	6	6	6	5	5	5	-	-

1) With reduced control voltage range 0,9 up to 1,0 x U_e and with reduced rated current I_e/AC1 according to I_e/AC3

2) Maximum cable cross-section with prepared conductor

Data according to IEC 947-4-1, EN 60947-4-1, VDE 0660

Auxiliary Contacts			Type	K(G)2-09	K(G)2-12	K(G)2-16	K2-23	K2-30	K2-37	K2-45	K2-60
Rated insulation voltage U_i¹⁾			V AC	690	690	690	-	-	-	-	-
Thermal rated current I_n to 690V											
Ambient temperature			40°C A	16	16	16	-	-	-	-	-
			60°C A	12	12	12	-	-	-	-	-
Utilization category AC15											
Rated operational current I_n											
			220-240V A	12	12	12	-	-	-	-	-
			380-415V A	4	4	4	-	-	-	-	-
			440V A	4	4	4	-	-	-	-	-
			500V A	3	3	3	-	-	-	-	-
			660-690V A	1	1	1	-	-	-	-	-
Utilization category DC13											
Rated operational current I_n											
			60V A	8	8	8	-	-	-	-	-
			110V A	1	1	1	-	-	-	-	-
			220V A	0,1	0,1	0,1	-	-	-	-	-
Short circuit protection											
short-circuit current 1kA, contact welding not accepted max. fuse size			gL (gG) A	25	25	25	-	-	-	-	-
For contactors with thermal overload relay the device with the smaller admissible control fuse (contactor or thermal overload relay) determines the fuse.											
Control Circuit											
Power consumption of coils											
AC operated											
			inrush VA	33-45	33-45	33-45	90-115	90-115	90-115	140-165	140-165
			sealed VA	7-10	7-10	7-10	9-13	9-13	9-13	13-18	13-18
			W	2,6-3	2,6-3	2,6-3	2,7-4	2,7-4	2,7-4	5,4-7	5,4-7
DC operated											
w. econ. circuit up to 24/above 24V			inrush W	75	75	75	140	140	140	200	200
			sealed W	2/7	2/7	2/7	2	2	2	6	6
DC solenoid operated (KG2-...)											
			inrush W	6,5	6,5	6,5	-	-	-	-	-
			sealed W	6,5	6,5	6,5	-	-	-	-	-
Operation range of coils											
in multiples of control voltage U_c											
			AC operated	0,85-1,1	0,85-1,1	0,85-1,1	0,85-1,1	0,85-1,1	0,85-1,1	0,85-1,1	0,85-1,1
			DC operated	0,8-1,1	0,8-1,1	0,8-1,1	0,8-1,1	0,8-1,1	0,8-1,1	0,8-1,1	0,8-1,1
Switching time											
at control voltage $U_c \pm 10\%$ ²⁾³⁾											
AC operated											
			make time ms	8-16	8-16	8-16	10-25	10-25	10-25	12-28	12-28
			release time ms	5-13	5-13	5-13	8-15	8-15	8-15	8-15	8-15
			arc duration ms	10-15	10-15	10-15	10-15	10-15	10-15	10-15	10-15
DC operated											
with AC magnet system			make time ms	8-12	8-12	8-12	10-20	10-20	10-20	12-23	12-23
			release time ms	8-13	8-13	8-13	10-15	10-15	10-15	10-18	10-18
			arc duration ms	10-15	10-15	10-15	10-15	10-15	10-15	10-15	10-15
Cable cross-section											
Auxiliary connector											
			solid mm ²	0,75-4	0,75-4	0,75-4	-	-	-	-	-
			flexible mm ²	0,75-2,5	0,75-2,5	0,75-2,5	-	-	-	-	-
			flexible with multicore cable end mm ²	0,5-2,5	0,5-2,5	0,5-2,5	-	-	-	-	-
Magnet coil											
			solid mm ²	0,75-2,5	0,75-2,5	0,75-2,5	0,75-2,5	0,75-2,5	0,75-2,5	0,75-2,5	0,75-2,5
			flexible mm ²	0,5-2,5	0,5-2,5	0,5-2,5	0,5-2,5	0,5-2,5	0,5-2,5	0,5-2,5	0,5-2,5
			flexible with multicore cable end mm ²	0,5-1,5	0,5-1,5	0,5-1,5	0,5-1,5	0,5-1,5	0,5-1,5	0,5-1,5	0,5-1,5
Clamps per pole											
				2	2	2	2	2	2	2	2

1) Suitable for: earthed-neutral systems, overvoltage category I to IV, pollution degree 3 (standard-industry): $U_{imp} = 8kV$. Data for other conditions on request

2) Total breaking time = release time + arc duration

3) Values for delay of the release time of the make contact and the make time of the break contact will be increased, if magnet coils are protected against voltage peaks (varistor, RC-unit, diode-unit)

Contactors for North America



Data according to UL508

Type	K85	K110	K3-150	K3-175	K3-200	K3-315	K3-450	K3-550	K3-700	K3-860	K3-1000	K3-1200
A	125	125	-	-	-	-	420	520	700	810	-	1215
hp	25	-	-	-	-	-	-	-	-	-	-	-
hp	-	30	-	-	-	-	125	150	200	250	-	450
hp	35	40	-	-	-	-	125	150	250	300	-	450
hp	-	-	-	-	-	-	-	-	-	-	-	-
hp	-	-	-	-	-	-	-	-	-	-	-	-
hp	65	75	-	-	-	-	250	350	500	600	-	900
hp	85	100	-	-	-	-	250	350	500	600	-	900
hp	8	10	-	-	-	-	-	-	-	-	-	-
hp	-	20	-	-	-	-	-	-	-	-	-	-
hp	20	20	-	-	-	-	-	-	-	-	-	-
hp	-	-	-	-	-	-	-	-	-	-	-	-
hp	-	-	-	-	-	-	-	-	-	-	-	-
hp	-	50	-	-	-	-	-	-	-	-	-	-
hp	-	60	-	-	-	-	-	-	-	-	-	-
hp	-	-	-	-	-	-	-	-	-	-	-	-
hp	-	-	-	-	-	-	-	-	-	-	-	-
hp	-	-	-	-	-	-	-	-	-	-	-	-
A	-	62	-	-	-	-	-	-	-	-	-	-
A	-	300	-	-	-	-	-	-	-	-	-	-
A	10000	10000	-	-	-	-	-	-	-	-	-	-
V	600	600	-	-	-	-	-	-	-	-	-	-
	A600	A600	-	-	-	-	A600	A600	A600	A600	-	A600

Main Contacts (cULus)	Type	MC18K	MC24K	MC32K	MC50K	MC62K	MC74K
Rated operational power of 3-phase capacitor banks at 60Hz (3ph)	110-120V kVAr	3,5	5,5	7	10	15	18
	200V kVAr	6	10	12,5	16,7	25	32
	220-240V kVAr	7	11	15	20	30	36
	440-480V kVAr	15	25	30	40	60	72
	550-600V kVAr	18	30	35	50	75	90
Fuses Suitable for use on a capability of delivering not more than	A	50	90	125	175	225	250
	rms A	5000	5000	5000	5000	5000	5000
	V	600	600	600	600	600	600
Auxiliary Contacts (cULus)		A600	-	-	-	-	-

Contactors



Data according to IEC 947-4-1, EN 60947-4-1, VDE 0660

Contact Life

For selection of the suitable contactor-type according to supply voltage, power rating and application (utilization category AC1, AC3 or AC4) use contact life characteristic diagram.

For contactors frequently used under AC3/AC4-mixed service conditions calculate contact life with the formula:

For the most common supply voltages four scales of power ratings P_n are provided for each utilization category.

$$M = \frac{AC3}{1 + \frac{\%AC4}{100}} \times \left(\frac{AC3}{AC4} - 1 \right)$$

Select contactor-type according to utilization category AC3 (breaking current $I_b = I_n$) using the motor rating scales to the right, according to utilization category AC4 (breaking current $I_b = 6 \times I_n$) using the motor rating scales to the left. ¹⁾

M = Contact life (switching cycles) for AC3/AC4-mixed operations
 AC3 = Contact life (switching cycles) for AC3 operations (normal switching conditions).
 Breaking current I_b = rated motor current I_n .
 AC4 = Contact life (switching cycles) for AC4 operations (inching).
 Breaking current I_b = multiples of rated motor current I_n .
 %AC4 = Percents of AC4-operations related to the total cycles.

Select contactor-type according to utilization category AC1 (breaking current $I_b = I_n/AC1$) using the breaking current scale. ¹⁾

Motor Rating $P_n/AC4$

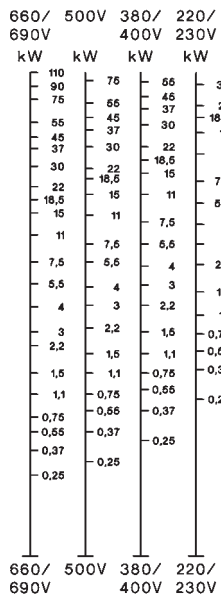

Motor Rating $P_n/AC3$

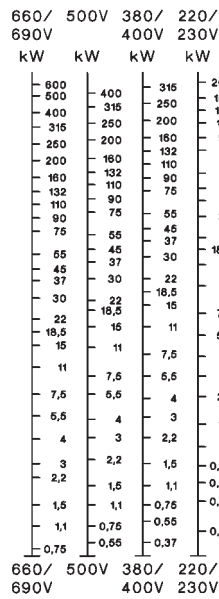

Breaking Current $I_b (= I_n/AC1)$ A

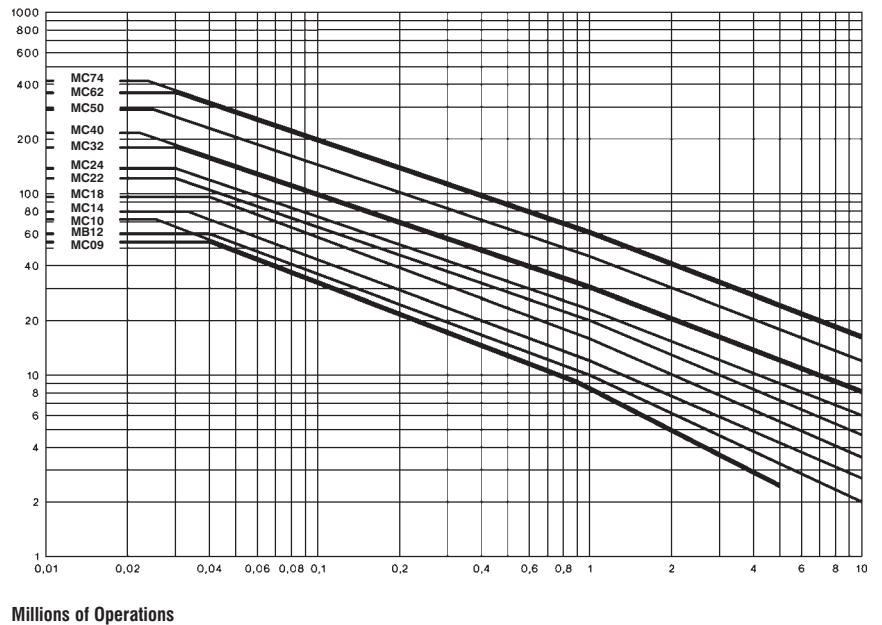

Motor Rating $P_n/AC4$

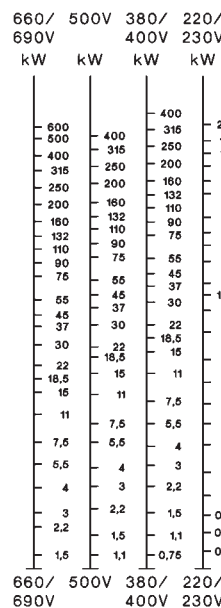

Motor Rating $P_n/AC3$

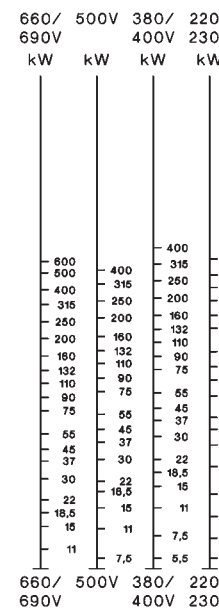

Breaking Current $I_b (= I_n/AC1)$ A

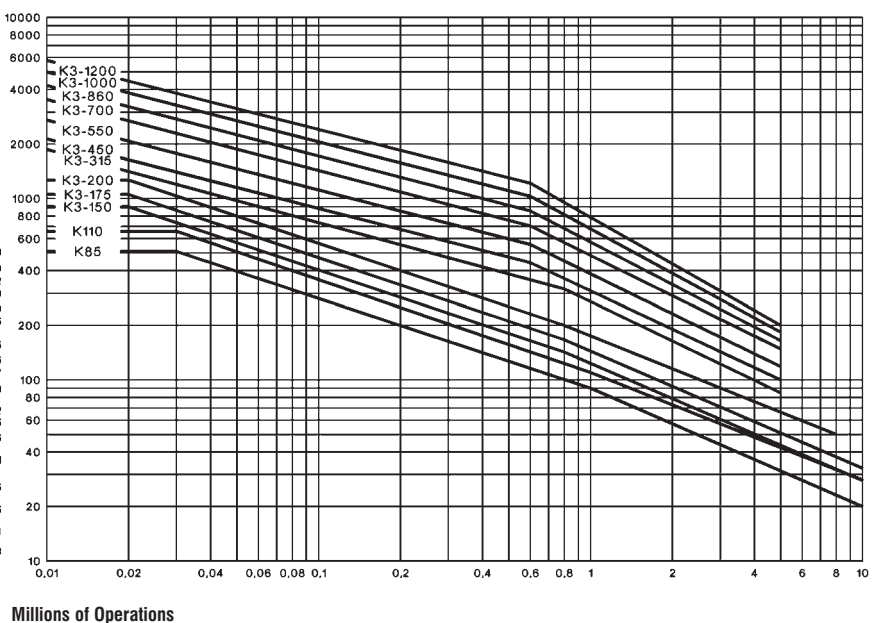

1) Pay attention to the approved rated values of the selected contactor according to the national approvals

Utilisation Categories

For easier choice of devices and in order to make the comparison of different products simpler are utilization categories for contactors and motor-starters according to IEC 947-4-1 and VDE 0660 Part 102, for control circuit devices and switching elements according to IEC 947-5-1 and VDE 0660 Part 200 determined. The table offers divers utilization categories, typical applications and assorted test conditions.

Kind of current	Category	Typical applications	Rated operational current	Test conditions for the number of on-load operating cycles						Test conditions for making and breaking capacities					
				Make			Break			Make			Break		
				I/I_n	U/U_n	$\cos\varphi$	I/I_n	U/U_n	$\cos\varphi$	I/I_n	U/U_n	$\cos\varphi$	I/I_n	U/U_n	$\cos\varphi$
Alternating Current	AC1	Non-inductive or slightly inductive loads resistance furnaces	all values	1	1	0,95	1	1	0,95	1,5	1,05	0,8	1,5	1,05	0,8
	AC2	Slip-ring motors: starting, switching off	all values	2,5	1	0,65	2,5	1	0,65	4	1,05	0,65	4	1,05	0,65
	AC3	Squirrel-cage motors: starting, switching off motors during running	$17A < \frac{I_n}{I_{th}}$ 17A 100A $\frac{I_n}{I_{th}} > 100A$	6 6 6	1 1 1	0,65 0,35 0,35	1 1 1	0,17 0,17 0,17	0,65 0,35 0,35	10 10 10	1,05 1,05 1,05	0,45 0,45 0,35	8 8 8	1,05 1,05 1,05	0,45 0,45 0,35
	AC4	Squirrel-cage motors: starting, plugging, inching	$17A < \frac{I_n}{I_{th}}$ 17A 100A $\frac{I_n}{I_{th}} > 100A$	6 6 6	1 1 1	0,65 0,35 0,35	6 6 6	1 1 1	0,65 0,35 0,35	12 12 12	1,05 1,05 1,05	0,45 0,45 0,35	10 10 10	1,05 1,05 1,05	0,45 0,45 0,35
	AC5a	Switching of electric discharge lamp controls	all values	-	-	-	-	-	-	3	1,05	0,45	3	1,05	0,45
	AC5b	Switching of incandescent lamps	all values	-	-	-	-	-	-	1,5	1,05	1)	4	1,05	1)
	AC6a	Switching of transformers	$\frac{I_n}{I_{th}}$ 100A $\frac{I_n}{I_{th}} > 100A$	- -	- -	- -	- -	- -	- -	4,5 4,5	1,05 1,05	0,45 0,35	3,6 3,6	1,05 1,05	0,45 0,35
	AC6b	Switching of capacitor banks	-	-	-	-	-	-	-	2)			2)		
	AC7a	Slightly inductive loads in household appliances and similar applications	all values	-	-	-	-	-	-	1,5	1,05	0,8	1,5	1,05	0,8
	AC7b	Motor loads for household applications	$\frac{I_n}{I_{th}} > 100A$	-	-	-	-	-	-	8 8	1,05 1,05	0,45 0,35	6 6	1,05 1,05	0,45 0,35
	AC8a	Hermetic refrigerant compressor motor control with manual resetting of overload releases	$\frac{I_n}{I_{th}} > 100A$	-	-	-	-	-	-	6 6	1,05 1,05	0,45 0,35	6 6	1,05 1,05	0,45 0,35
	AC8b	Hermetic refrigerant compressor motor control with automatic resetting of overload releases	$\frac{I_n}{I_{th}} > 100A$	-	-	-	-	-	-	6 6	1,05 1,05	0,45 0,35	6 6	1,05 1,05	0,45 0,35
	AC12	Control of resistive loads and solid state loads with isolation by opto couplers	all values	-	-	-	-	-	-	1	1	0,9	1	1	0,9
	AC13	Control of solid state loads with transformer isolation	all values	-	-	-	-	-	-	10	1,1	0,65	1,1	1,1	0,65
	AC14	Control of small electromagnetic loads ($\leq 72VA$)	-	-	-	-	-	-	-	6	1,1	0,7	6	1,1	0,7
AC15	Control of electromagnetic load ($>72VA$)	-	10	1	0,7	1	1	0,4	10	1,1	0,3	10	1,1	0,3	
				Make I/I_n	U/U_n	L/R [ms]	Break I/I_n	U/U_n	L/R [ms]	Make I/I_n	U/U_n	L/R [ms]	Break I/I_n	U/U_n	L/R [ms]
Direct Current	DC1	Non-inductive or slightly inductive loads resistance furnaces	all values	1	1	1	1	1	1	1,5	1,05	1	1,5	1,05	1
	DC3	Shunt-motors: starting, plugging, inching dynamic braking of d.c. motors	all values	2,5	1	2	2,5	1	2	4	1,05	2,5	4	1,05	2,5
	DC5	Series-motors: starting, plugging, inching dynamic braking of d.c. motors	all values	2,5	1	7,5	2,5	1	7,5	4	1,05	15	4	1,05	15
	DC6	Switching of incandescent lamps	all values	-	-	-	-	-	-	1,5	1,05	1)	4	1,05	1)
	DC12	Control of resistive loads and solid state loads with isolation by opto couplers	all values	-	-	-	-	-	-	1	1	1	1	1	1
	DC13	Control of electromagnets	all values	1	1	≤ 300	1	1	≤ 300	1,1	1,1	≤ 300	1,1	1,1	≤ 300
	DC14	Control of electromagnetic loads having economy resistors in circuit	all values	-	-	-	-	-	-	10	1,1	15	10	1,1	15

U_n Rated operational voltage, U Voltage before make, U_r Recovery voltage, I_n Rated operational current, I Current make, I_b Current broken

1) Test with incandescent lamps

2) Test conditions according to standard

Accessories

Data according to IEC 947-4-1, EN 60947-4-1, VDE 0660

Type		MCA	MCAM	MCAH	MCAS	HKS HKD HKF, HKB	MC-DK MC-SK	MCT-P	MCL- ²⁾	
Rated insulation voltage U_i ¹⁾	V AC	690	690	690	690	690	690	690	690	
Thermal rated current I_m to 690V Ambient temperature	max. 40°C	A	10	10	25	10	10	26	10	-
	max. 60°C	A	6	6	20	6	-	-	-	-
Frequency of operations z	1/h	3000	-	3000	3000	-	-	1200	3000	
Mechanical life	S x 10 ⁶	10	10	10	10	-	-	1	10	
Power loss per pole at $I_e/AC1$	W	0,5	0,5	1,5	0,5	-	-	-	-	
Utilization category AC15										
Rated operational current I_e	220-240V	A	3	3	6	3	3	-	4	-
	380-400V	A	2	2	3	2	2	-	3	-
	440V	A	1,6	1,6	2	1,6	1,5	-	2	-
	500V	A	1,2	1,2	2	1,2	1,5	-	2	-
660-690V	A	0,6	0,6	1	0,6	1	-	2	-	
Utilization category DC13										
Rated operational current I_e	60V	A	2	2	8	2	-	-	2,5	-
	110V	A	0,4	0,4	1	0,4	0,5	-	1,5	-
	220V	A	0,1	0,1	0,1	0,1	0,2	-	0,2	-
Short circuit protection short-circuit current 1kA, contact welding not accepted max. fuse size	gL (gG)	A	20	20	25	20	10	-	10	-
For contactors with thermal overload relay or auxiliary contacts the device with the smaller admissible control fuse (contactor or thermal overload relay) determines the fuse size.										
Cable cross-sections										
Cables per clamp	solid or stranded	mm ²	0,75-2,5	0,75-2,5	0,75-2,5	0,75-2,5	0,75-2,5	0,75-2,5	1-2,5	0,75-2,5
	flexible	mm ²	0,75-2,5	0,75-2,5	0,75-2,5	0,75-2,5	0,75-2,5	0,75-2,5	0,75-2,5	0,75-2,5
	flexible with multicore cable end	mm ²	0,5-1,5	0,5-1,5	0,5-1,5	0,5-1,5	0,5-1,5	0,5-1,5	0,75-2,5	0,5-1,5
			2	2	2	2	2	2	2	2

Data according to CSA, UL and CUL

Type		MCA	MCAM	MCAH	MCAS	HKS	MC-DK MC-SK	MCT-P	MCL- ²⁾
Rated operational current "General Use"	A	10	10	16	10	10	-	10	-
Rated operational voltage	max. V AC	600	600	600	600	600	-	600	600
Auxiliary Contacts		A600	A600	A600	A600	A600	-	A600	Intermittent duty

1) Suitable for: earthed-neutral systems, overvoltage category I to IV, pollution degree 3 (standard-industry): $U_{imp} = 8kV$. Data for other conditions on request.

2) Operation range of magnet coils 0,8 up to 1,1 x rated operational voltage U_e , command duration min. 30ms, 100% duty cycle

Contactors and Accessories



Wiring diagrams

Auxiliary contact blocks

MCA10
MCAH10

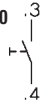

MCA01
MCAH01



MCA10U



MCA01U



Snap-on momentary contact blocks

MCAM10

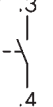

MCAM01



HKS11
HKD11

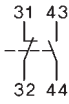

MCAS-11
HKS11A

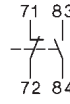
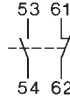

MCAS-11, HKS11A: Correct terminal marking is given by mounting.

HKF22

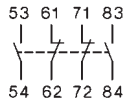
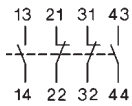

state of delivery

NO contacts position related to the main poles can be regulated by user screwing or unscrewing the adjustable screw.

HKF22

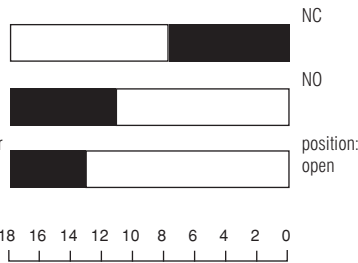

Standard position of regulation screw

NO/NC overlapped

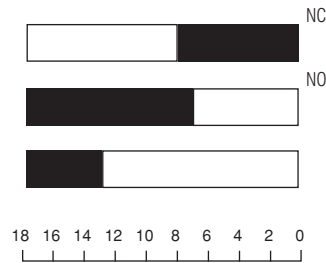

Regulation screw position (unscrew by 4 turns)

NO delayed

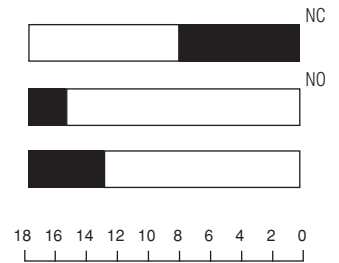

Regulation screw position (screw by 4 turns)

Pneumatic timer

on-delayed

MCT-PA..

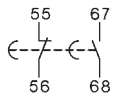

off-delayed

MCT-PB..

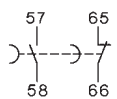

Indicator units

Coil current indicator

MC-ING
MC-INR

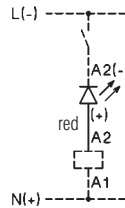

Voltage indicator

MC-UN
MC-UNR

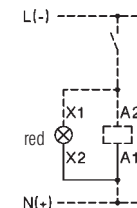

Latch

MC-L..L



Fuse holder

MC-F



with rectifier

K2-RF1
K2-RF3

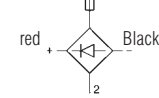

Colours mentioned in wiring diagram refer to the outgoing connection wires of the device.

Interface

K2-IM

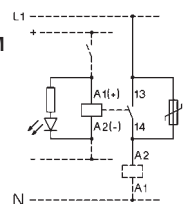

Contactors

Dimensions

AC operated

MC10..
MC14..
MC18..
MC22..

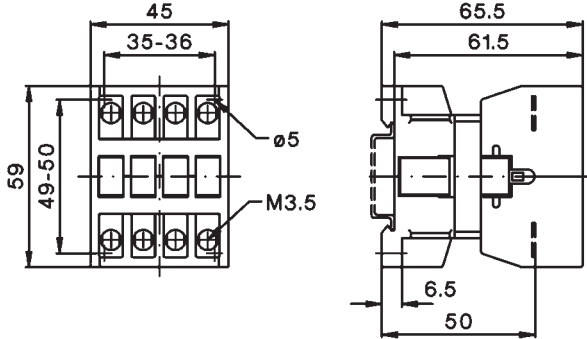

DC operated

MC10..=
MC14..=
MC18..=
MC22..=

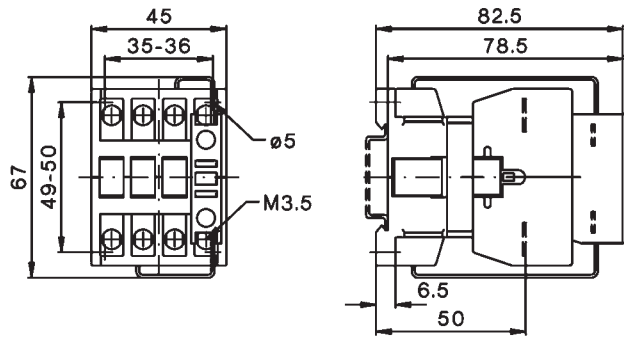

MC24..
MC32..
MC40..

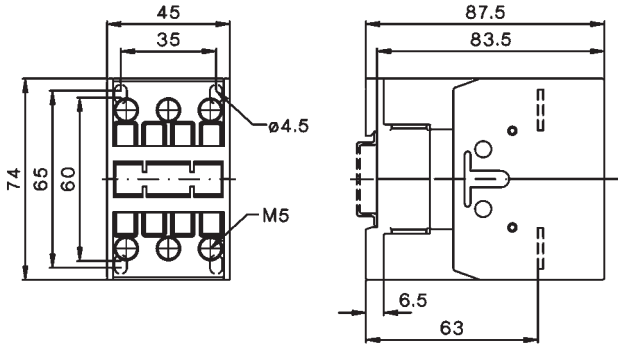

MC24..=
MC32..=
MC40..=

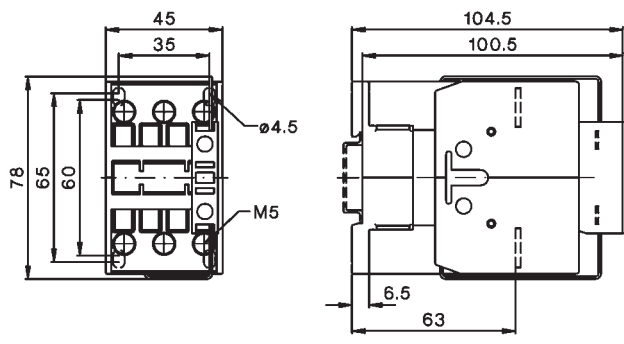

MC50..
MC62..
MC74..

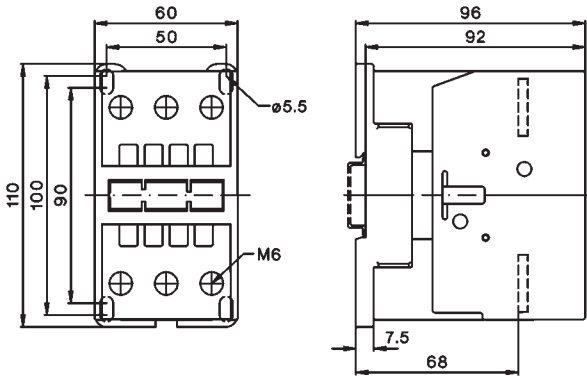

MC50..=
MC62..=
MC74..=

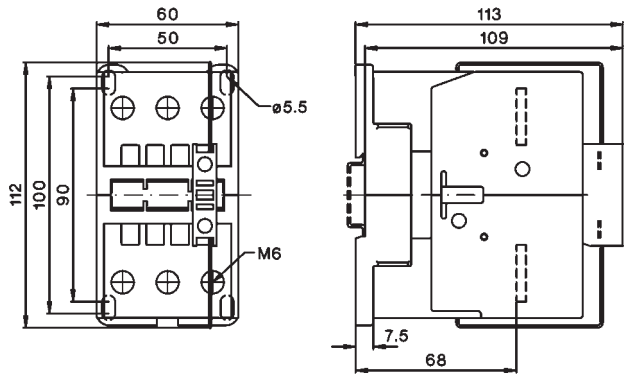

AC and DC operated

K85..
K110..

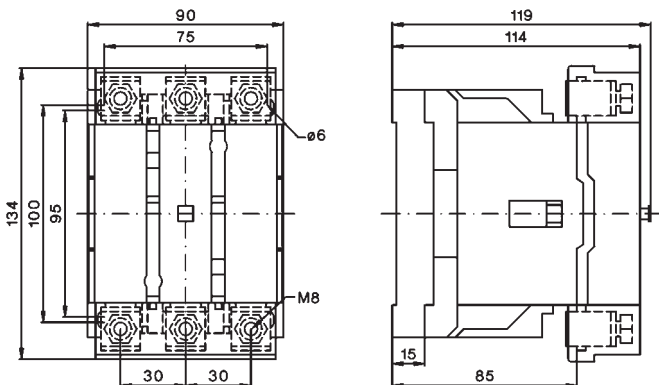

Contactors

Dimensions

AC operated

K3-150..
K3-175..

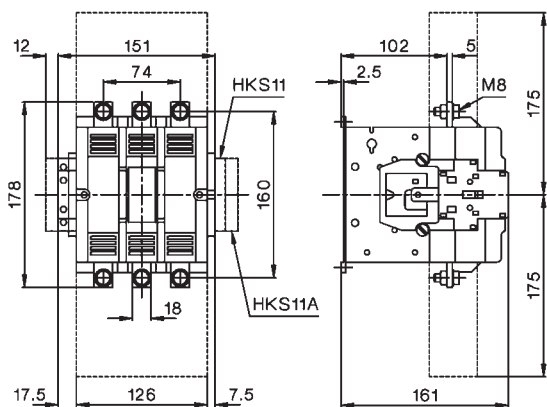

DC operated

K3-150..
K3-175..

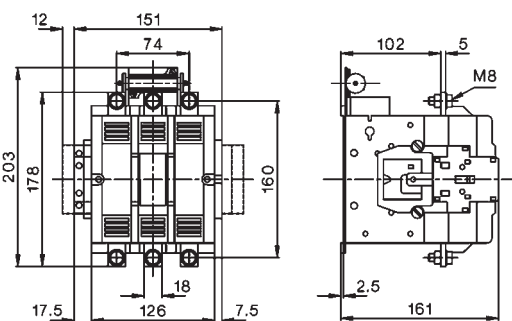

K3-200..

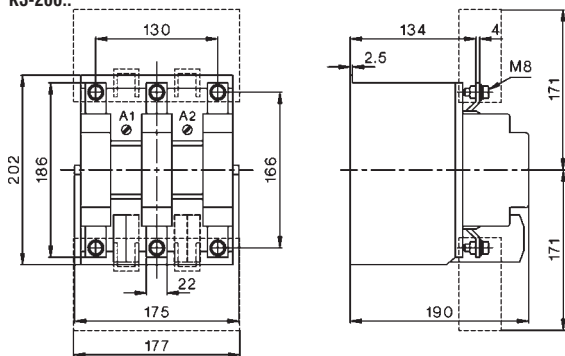

K3-200..=

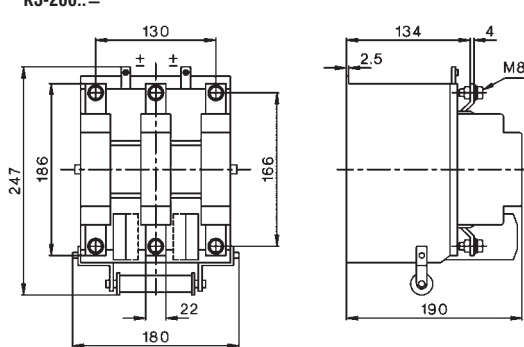

K3-315..

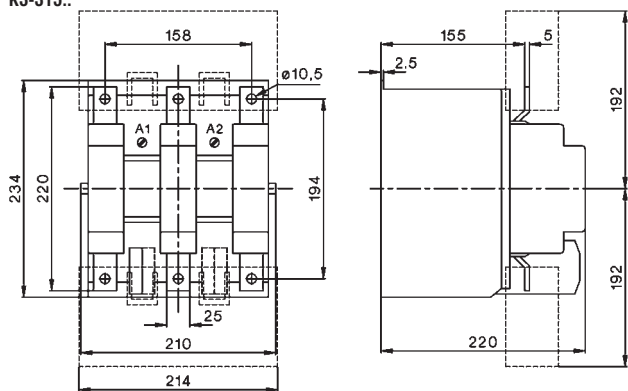

K3-315..=

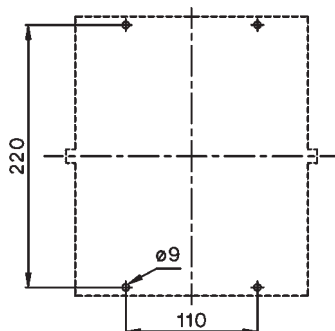
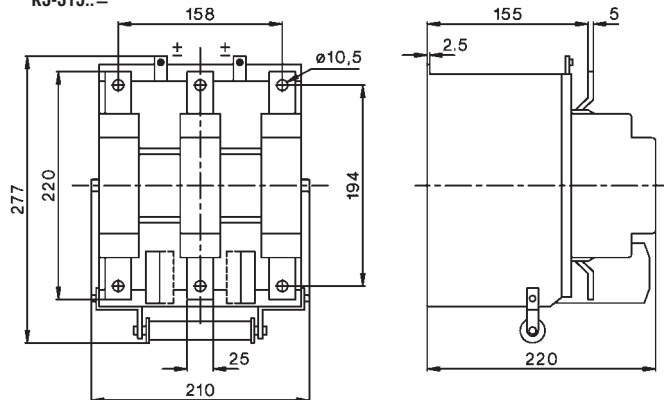

Contactors

Dimensions

AC and DC operated

K3-450..
K3-550..

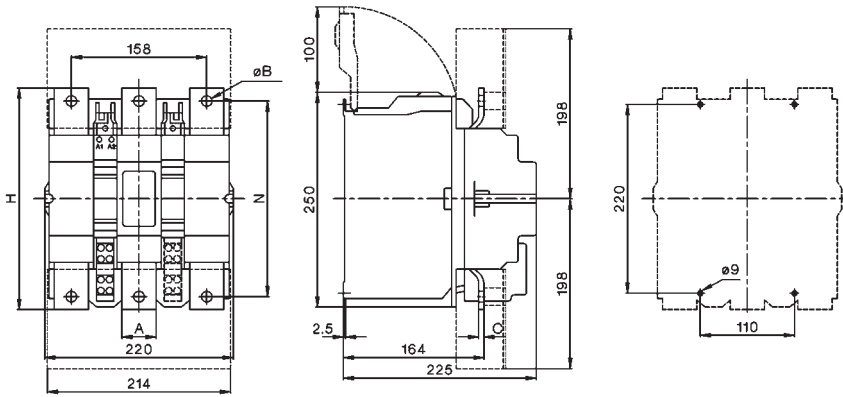

Type	A	B	C	H	N
K3-450	30	10,5	5	233	206
K3-550	40	12,5	6	258	228

K3-700..
K3-860..

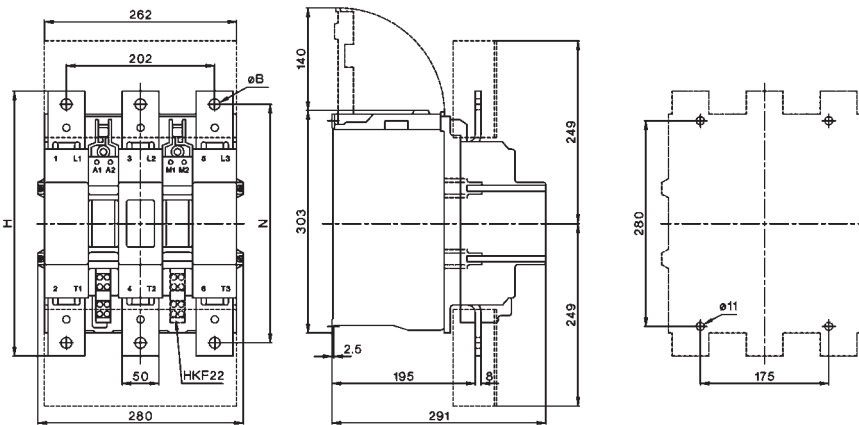

Type	A	H	N
K3-700	13	310	277
K3-860	15	361	325

K3-1000..
K3-1200..

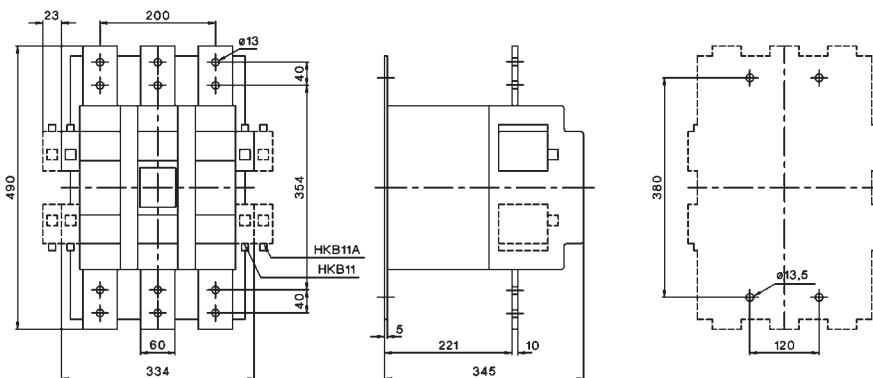

Contactors

Dimensions

Contactors 4-pole, AC operated

- MC10-S-00-40
- MC14-S-00-40
- MC18-S-00-40
- MC22-S-00-40

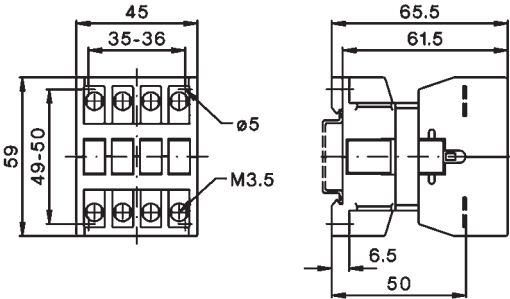

- K2-23A00-40
- K2-30A00-40
- K2-37A00-40

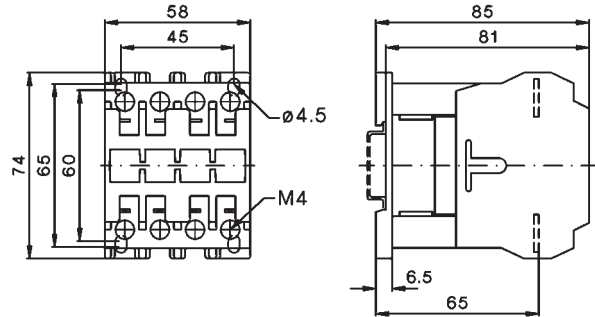

Contactors 4-pole, AC operated

- K2-45A00-40
- K2-60A00-40

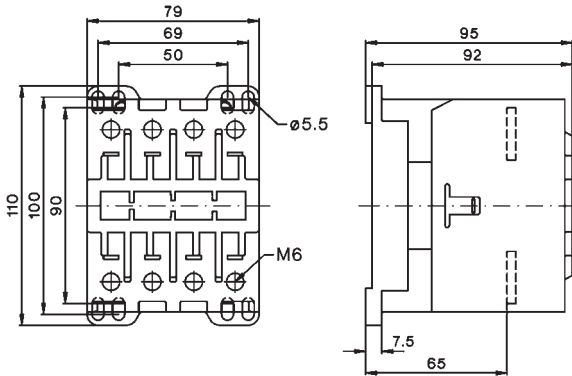

Contactors DC solenoid operated

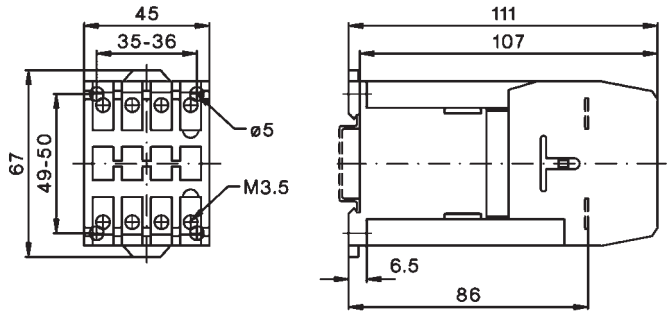

Capacitor switching contactors, AC operated

- MC18K..

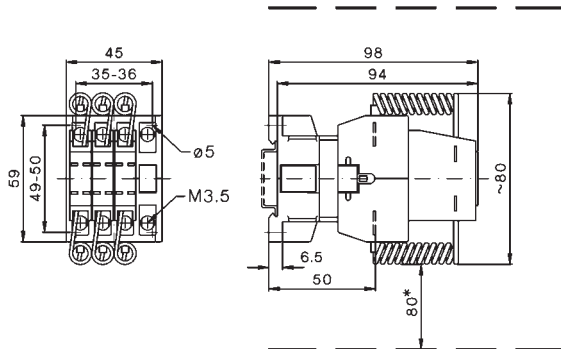

- MC24K..
- MC32K..

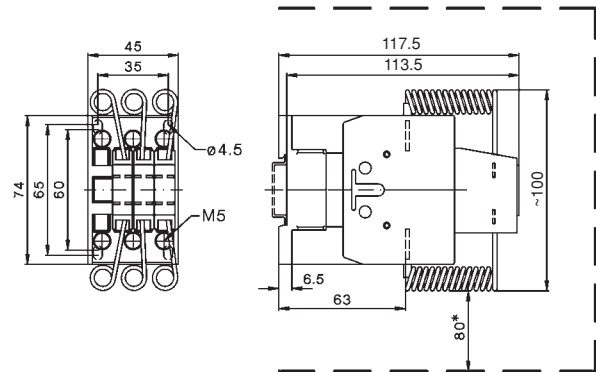

Capacitor switching contactors, AC operated

- MC50K..
- MC62K..
- MC74K..

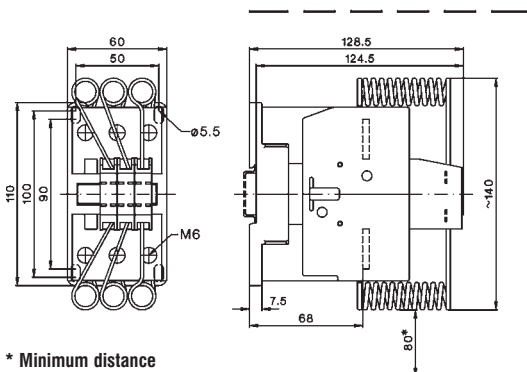

* Minimum distance

Contactors

Dimensions Accessories

Aux. cont. blocks, terminal blocks

MCA10/01

MC-SK, MC-DK

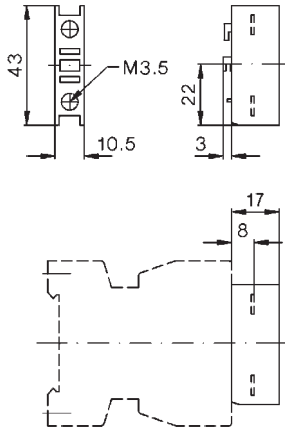

Snap-on momentary cont. blocks

MCAM10/01

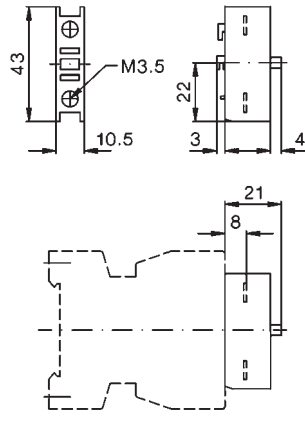

Auxiliary contact blocks

MCAH10/01

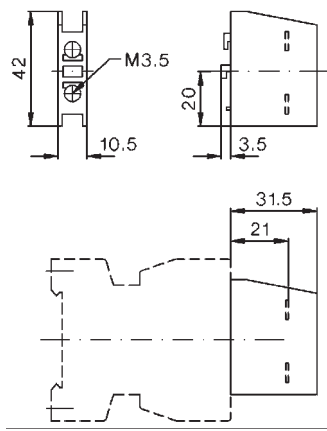

MCAS-11

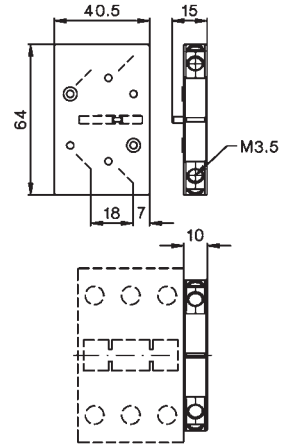

4. pole for contactors K3..

Type	A	B	C	D	E	F	G	H
NP120	168	102	21	46	48	3	76	M8
NP250	185	148	26	60	89	5	122	M8
NP175	223	148	26	52	98	5	122	M8
NP350	223	148	26	52	98	5	122	M8
NP325	262	148	26	55	116	5	122	M10
NP500	294	220	53	72	138	5	152	M12
NP760	294	220	53	72	138	5	152	M12
NP501	348	220	53	73	145	5	152	M12
NP1000	348	220	53	73	145	8	152	M12
NP1001	410	220	53	110	157	8	152	M12

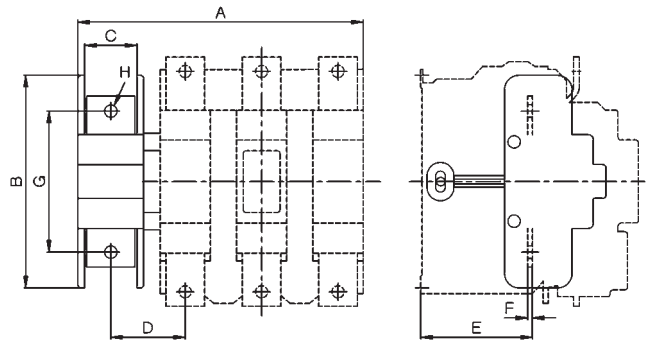

Electronic timer on-delay

MCT-A..

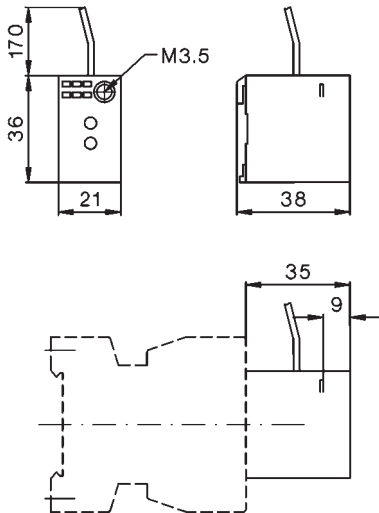

Electronic timer off-delay

MCT-B..

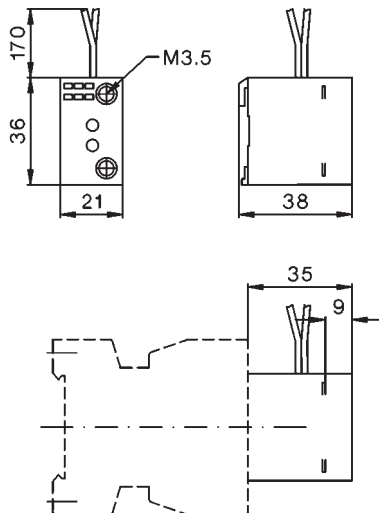

Pneumatic timer

MCT-P..

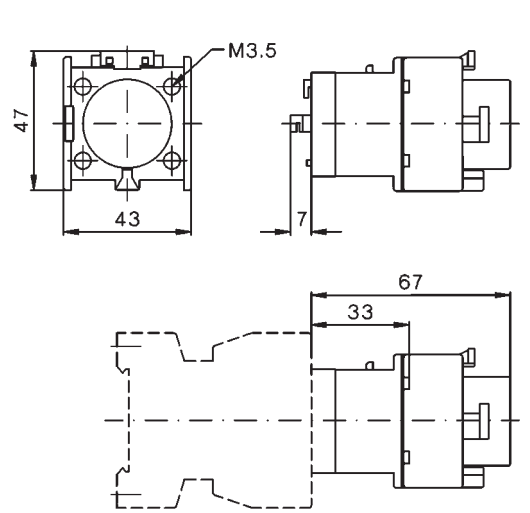

Contactors

Dimensions Accessories

Mechanical interlocks

MC-I-W, MC-I-X, LG8511

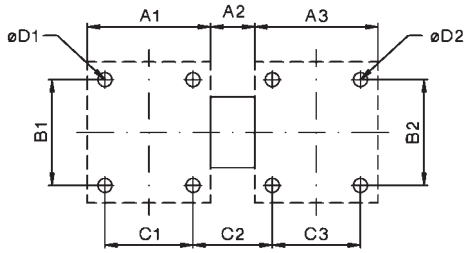

LG10397H

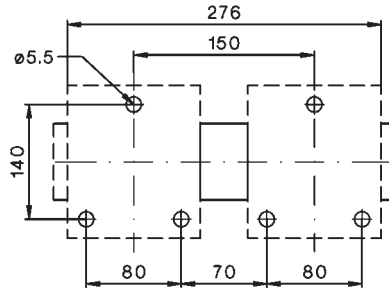

Type	Contactor 1	Contactor 2	A1	A2	A3	B1	B2	C1	C2	C3	D1	D2
MC-I-W	MC07 to MC40	MC07 to MC40	45	7	45	50	50	35	17	35	4,5	4,5
MC-I-W	K(G)2-09, -12, -16	K(G)2-09, -12, -16	45	7	45	50	50	35	17	35	4,5	4,5
MC-I-X	MC50 to MC74	MC24 to MC40	60	12	55	100	65	50	22	45	5,5	4,5
MC-I-X	MC50 to MC74	MC50 to MC74	60	12	60	100	100	50	22	50	5,5	5,5
LG8511	K65 - K110	K65 - K110	90	12	90	100	100	75	27	75	6	6

LG10398H to LG10403H

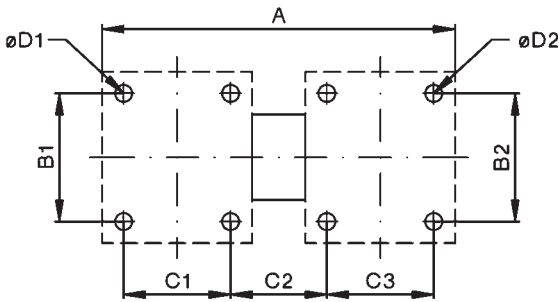

Type	Contactor 1	Contactor 2	A	B1	B2	C1	C2	C3	D1	D2
LG10398H	K3-200	K3-200	400	185	185	100	124,5	100	7	7
LG10400H	K3-315 - K3-550	K3-315 - K3-550	482	220	220	110	152	110	9	9
LG10402H	K3-700, -860	K3-700, -860	592	280	280	175	137	175	11	11
LG10403H	K3-1000, -1200	K3-1000, -1200	714	380	380	120	260	120	13,5	13,5
LG10399H	K3-450, -550	K3-700, -860	537	220	280	110	144,5	175	9	11
LG10401H	K3-700, -860	K3-1000, -1200	687	280	380	175	232,5	120	11	13,5

LG10398V, LG10400V, LG10402V

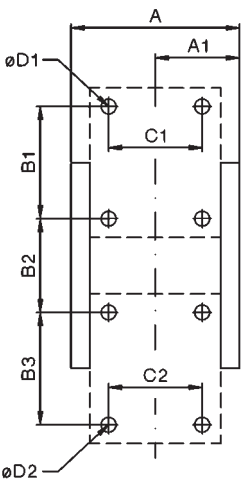

LG10399V

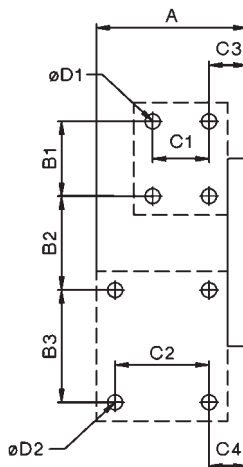

LG10403V, LG10401V

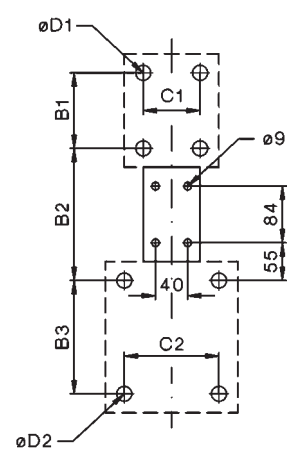

Type	Contactor 1	Contactor 2	A	A1	B1	B2	B3	C1	C2	C3	C4	D1	D2
LG10398V	K3-200	K3-200	217	118	185	85	185	100	100	-	-	7	7
LG10400V	K3-315 - K3-550	K3-315 - K3-550	250	134	220	94	220	110	110	-	-	9	9
LG10402V	K3-700, -860	K3-700, -860	302	162	280	200	280	175	175	-	-	11	11
LG10403V	K3-1000, -1200	K3-1000, -1200	-	-	380	280	380	120	120	-	-	13,5	13,5
LG10399V	K3-450, -550	K3-700, -860	302	-	220	150	280	110	175	51	74,5	9	11
LG10401V	K3-700, -860	K3-1000, -1200	-	-	280	240	380	175	120	-	-	11	13,5

Contactors

Dimensions Accessories

Latch

MC-L..

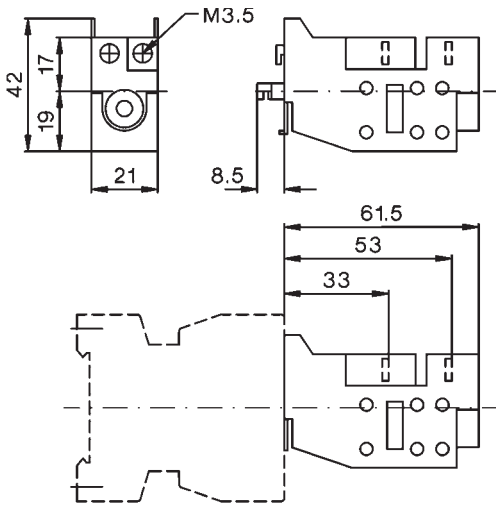

Contactors with additional terminals

LG9339 (2 x 3 pieces)

Contactors	A
MC10-S to MC22-S	40
KG2-09A to KG2-16A	86

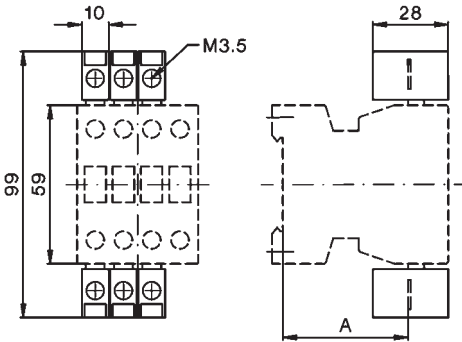

MC-DK, MC-SK

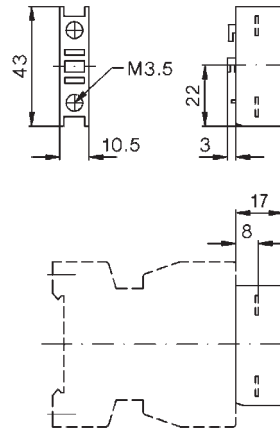

Indicator units

MC-ING, MC-INR
MC-UN, MC-UNR

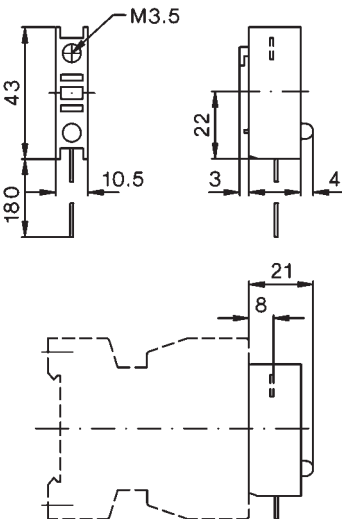

Fuse holder

MC-RF

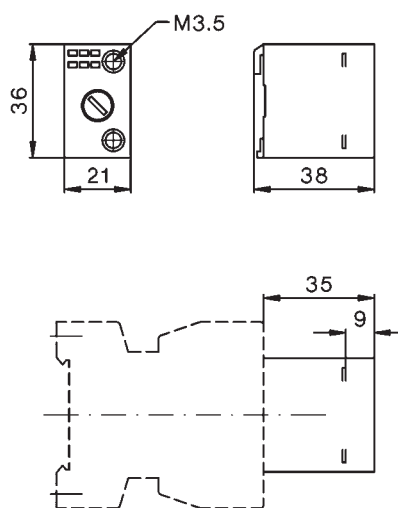

Fuse holder with rectifier

MC-RF1
MC-RF3

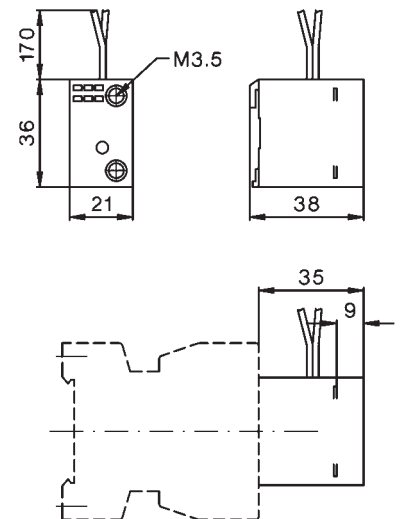

Contactors

Dimensions Accessories

Interface

MC-IM

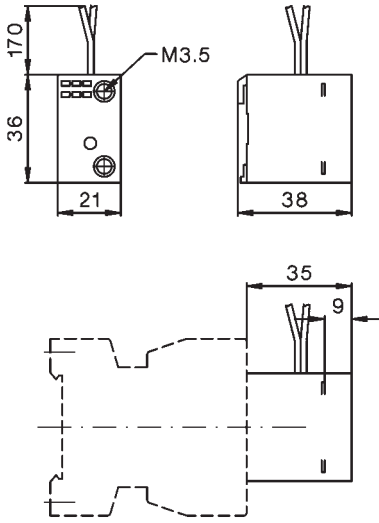

Snap-on adapter

MC-SM

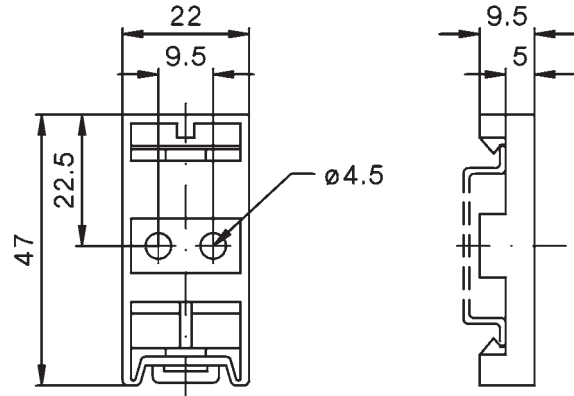

Suppressor units

MC-E..

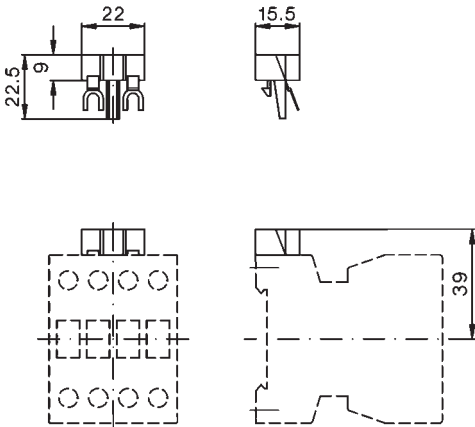

MC-VG/..

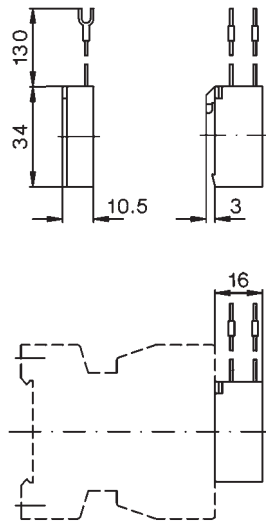

RC-AD.., LG-ADZ.., LG-A03

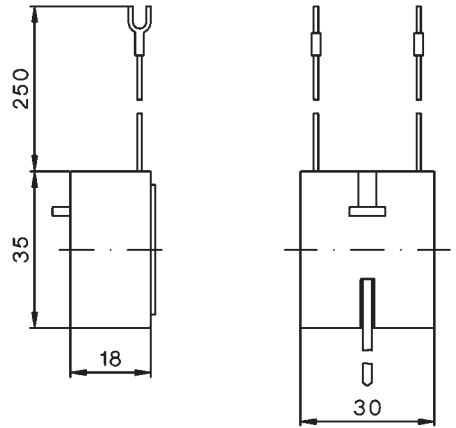

RCS..RCS..

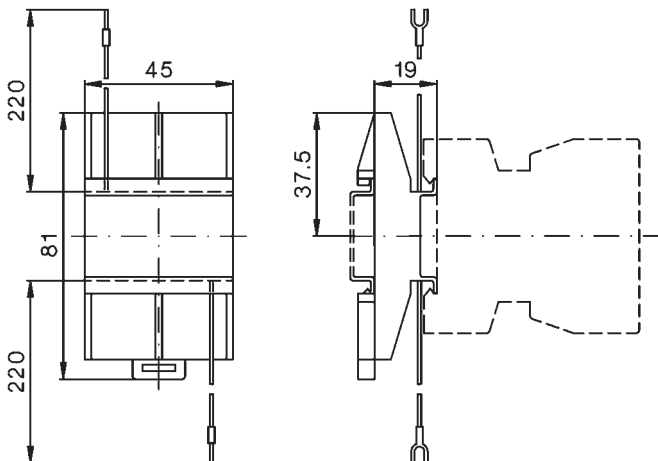

Marking systems

marking label
P487-1 or P245-.

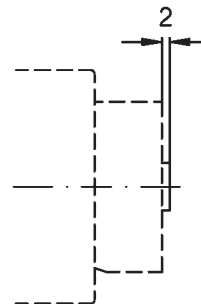

label holder P527-1 with
snap-on labels LG9337

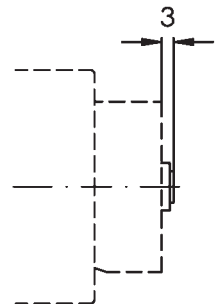

Contactors

Position of terminals

AC operated and DC solenoid operated

MC10-S-10 to
MC22-S-10
KG2-09A10 to
KG2-16A10
MC18-K-10

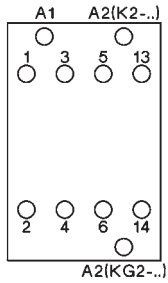

MC10-S-01 to
MC22-S-10
KG2-09A01 to
KG2-16A01
MC18-K-01

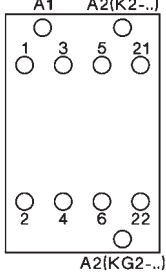

MC24-S-00, MC24-K-00
MC32-S-00, MC32-K-00
MC40-S-00

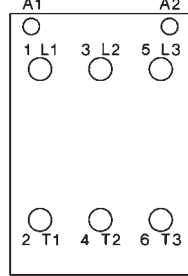

MC50-S-00, MC50-K-00
MC62-S-00, MC62-K-00
MC74-S-00, MC74-K-00

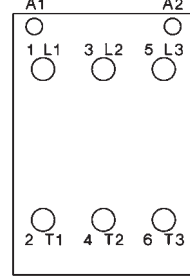

K85A22
K110A22
K2-45K00
K2-60K00

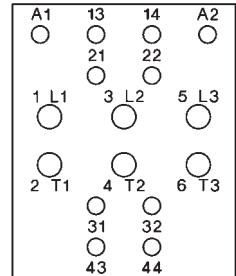

K3-150A11
K3-175A11

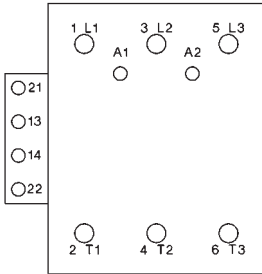

K3-200A22
K3-315A22

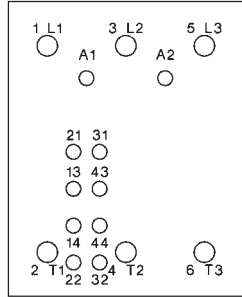

K3-1000A12
K3-1200A12

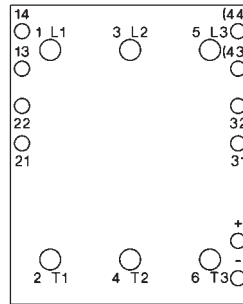

MC10-S-00-40, MC14-S-00-40
MC18-S-00-40, MC22-S-00-40
K2-30A00-40, K2-37A00-40
K2-45A00-40, K2-60A00-40

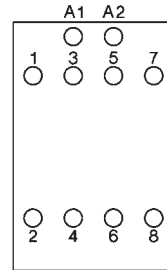

DC operated with double winding coil

MC10-S-10 to
MC10-S-10=
MC14-S-10=
MC18-S-10=
MC22-S-10=

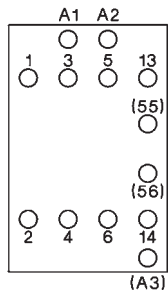

MC10-S-01 to
MC10-S-01=
MC14-S-01=
MC18-S-01=
MC22-S-01=

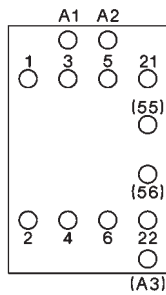

MC24-S-00, MC24-K-00
MC24-S-00=
MC32-S-00=
MC40-S-00=

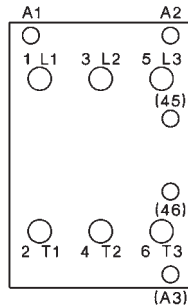

MC50-S-00, MC50-K-00
MC50-S-00=
MC62-S-00=
MC74-S-01=

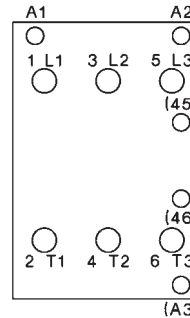

K85A22
K85A21=
K110A21=

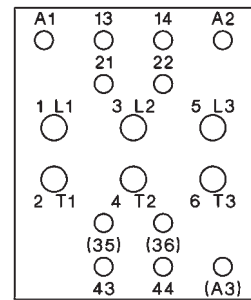

DC operated with series resistor

K3-150A11
K3-175A11

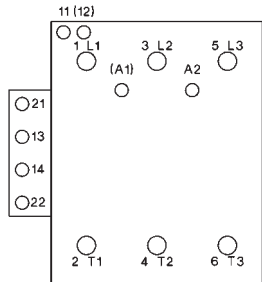

K3-200A21
K3-315A21

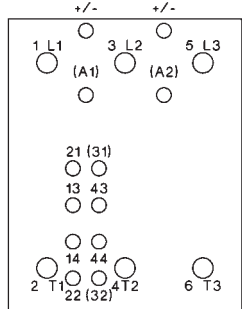

AC and DC operated

K3-450A22 bis
K3-860A22

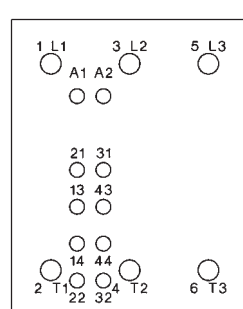

DC operated

K3-1000A12
K3-1200A12

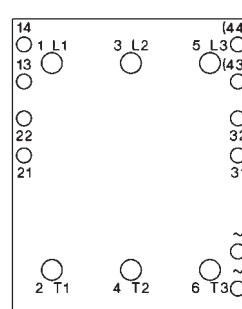

Thermal Overload Relays

for plug-in mounting



Setting Range D.O.L.	(A)	YΔ	(A)	Type	Pack pcs.	Weight kg/pc.
For contactors MC10.. to MC32..						
0,12	-	0,18	-	MCOR-1-0,18	1	0,14
0,18	-	0,27	-	MCOR-1-0,27	1	0,14
0,27	-	0,4	-	MCOR-1-0,4	1	0,14
0,4	-	0,6	-	MCOR-1-0,6	1	0,14
0,6	-	0,9	-	MCOR-1-0,9	1	0,14
0,8	-	1,2	-	MCOR-1-1,2	1	0,14
1,2	-	1,8	-	MCOR-1-1,8	1	0,14
1,8	-	2,7	-	MCOR-1-2,7	1	0,14
2,7	-	4	-	MCOR-1-4	1	0,14
4	-	6	7 - 10,5	 hand- and auto reset	1	0,14
6	-	9	10,5 - 15,5		1	0,14
8	-	11	14 - 19		1	0,14
10	-	14	18 - 24	 hand- and auto reset, built-in start button	1	0,14
13	-	18	23 - 31		1	0,14
17	-	24	30 - 41		1	0,14
23	-	32	40 - 55	MCOR-1-32	1	0,14



For contactors MC24.. to MC40 ..						
10	-	14	18 - 24	 hand- and auto reset, built-in start button	1	0,30
14	-	20	24 - 35		1	0,30
20	-	28	35 - 48	 hand- and auto reset, built-in start button	1	0,30
28	-	42	48 - 73		1	0,30



For contactors MC50.. to MC74..						
20	-	28	35 - 48	 hand- and auto reset, built-in start button	1	0,40
28	-	42	48 - 73		1	0,40
40	-	52	70 - 90	 hand- and auto reset, built-in start button	1	0,40
52	-	65	90 - 112		1	0,40
60	-	74			1	0,40

Thermal Overload Relays

for plug-in mounting



Setting Range D.O.L.	(A)	YΔ	(A)	Type	Pack pcs.	Weight kg/pc.
For contactors K85.. , K110.. , K3-150..						
60	-	90	104 - 156	 hand reset	1	0,90
80	-	120	140 - 207		1	0,90

Thermal Overload Relays

for separate mounting

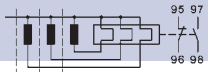
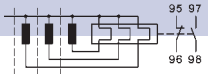
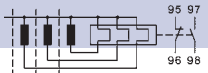
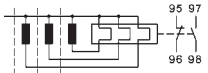

Setting Range D.O.L.	(A)	YΔ	(A)	Type	Pack pcs.	Weight kg/pc.	
For contactors K3-150.., K3-175.., K3-200.., K3-315							
100	- 150	175	- 260	 hand reset	1	1,5	
140	- 220	240	- 380		U205 150 U205 210	1	1,5
For contactors K3-315.., busbars included							
220	- 310	380	- 535	 hand- and auto reset	1	1,8	
					U310 310		
For contactors K3-315.., K3-450.., K3-550.., K3-700.., K3-860							
260	- 360	450	- 620	 hand- and auto reset	1	4,1	
340	- 480	590	- 830		U840 360 U840 480	1	4,1
440	- 620	760	- 1070		U840 620	1	4,1
560	- 800	970	- 1385		U840 800	1	4,1
busbar sets see accessories							
For contactors K3-1000.., K3-1200..							
700	- 1000	1200	- 1730	 hand- and auto reset	1	7,0	
875	- 1250	1510	- 2160		U1250 1000 U1250 1000	1	7,0
busbars must be installed by user							



Accessories

for overload relays	for contactors			Type	Pack set	Weight kg/set
Busbar Sets						
U205	K3-150.., K3-175..			SU205/175	1	0,6
U205	K3-200..			SU205/200	1	0,7
U205	K3-315..			SU205/315	1	0,8
U840	K3-315.., K3-450.., K3-550..			SU840/550	1	1,7
U840	K3-700.., K3-860..			SU840/860	1	2,1
U1250	K3-1000.., K3-1200..			busbars must be installed by user		
for overload relay	Cable Cross-section to clamp (mm ²)			Type	Pack pcs.	Weight kg/pc.
	solid or stranded	flexible	flex. with multi- core cable end			
Sets for Single Mounting for DIN-rail mounting						
U3/32	0,75 - 6	0,75 - 4	0,5 - 4	U3/32SM	1	0,035
U3/42, U3/74	4 - 35	6 - 25	4 - 25	U3/42G	1	0,035
U12/16	0,75 - 6	0,75 - 4	0,5 - 4	U12SM	1	0,035
Additional Terminals with fingertouch protection						
3-pole for U3/42	4 - 35	6 - 25	4 - 25	LG7559	1	0,052
1-pole for U3/32 U12/16	0,75 - 10	0,75 - 6	0,75 - 6	LG9339	1	0,009
Marking System						
Snap-on Labels	for U12/16 to U205, marked choice of F, 0 to 9, 1 strip (10 pcs)			LG9337--	10	0,008



Thermal Overload Relays With Special Tripping Characteristics

Setting Range D.O.L.	(A)	$\Upsilon\Delta$	(A)	Type	Pack pcs.	Weight kg/pc.	
With Quick Tripping Characteristic for EEx e motors and submersible pumps For contactors MC10.. to MC40. , K2-09.. to K2-37..							
0,4 - 0,6	-	-	-		1	0,10	
0,6 - 0,9	-	-	-		U12/16UQ 0,9	1	0,10
0,8 - 1,2	-	-	-		U12/16UQ 1,2	1	0,10
1,2 - 1,8	-	-	-	hand reset	1	0,10	
1,8 - 2,7	-	-	-		U12/16UQ 2,7	1	0,10
2,7 - 4	-	-	-		U12/16UQ 4	1	0,10
4 - 6	7	-	10,5	U12/16UQ 6	1	0,10	
6 - 9	10,5	-	15,5	U12/16UQ 9	1	0,10	
8 - 11	14	-	19	U12/16UQ 11	1	0,10	
10 - 14	18	-	24	U12/16UQ 14	1	0,10	
With Magnetic Quick Tripping and hand reset For contactors MC10.. to MC40. , K2-09.. to K2-37..							
0,12 - 0,18	-	-	-		1	0,10	
0,18 - 0,27	-	-	-		U12/16EM 0,27	1	0,10
0,27 - 0,4	-	-	-		U12/16EM 0,4	1	0,10
0,4 - 0,6	-	-	-	hand reset	1	0,10	
0,6 - 0,9	-	-	-		U12/16EM 0,9	1	0,10
0,8 - 1,2	-	-	-		U12/16EM 1,2	1	0,10
1,2 - 1,8	-	-	-	magnetic quick tripping	1	0,10	
1,8 - 2,7	-	-	-		U12/16EM 2,7	1	0,10
2,7 - 4	-	-	-		U12/16EM 4	1	0,10
With Hand Reset For contactors MB09.. , MB12.. , MC10.. to MC40. , K2-09.. to K2-37..							
0,12 - 0,18	-	-	-	U12/16E 0,18	1	0,10	
0,18 - 0,27	-	-	-	U12/16E 0,27	1	0,10	
0,27 - 0,4	-	-	-	U12/16E 0,4	1	0,10	
0,4 - 0,6	-	-	-		1	0,10	
0,6 - 0,9	-	-	-		U12/16E 0,9	1	0,10
0,8 - 1,2	-	-	-		U12/16E 1,2	1	0,10
1,2 - 1,8	-	-	-	hand reset	1	0,10	
1,8 - 2,7	-	-	-		U12/16E 2,7	1	0,10
2,7 - 4	-	-	-		U12/16E 4	1	0,10
4 - 6	7	-	10,5	U12/16E 6	1	0,10	
6 - 9	10,5	-	15,5	U12/16E 9	1	0,10	
8 - 11	14	-	19	U12/16E 11	1	0,10	
10 - 14	18	-	24	U12/16E 14	1	0,10	
13 - 18	23	-	31	U12/16E 18	1	0,10	
17 - 23	30	-	40	U12/16E 23	1	0,10	
22 - 30	38	-	52	U12/16E 30	1	0,10	
With Slow Tripping Characteristic for heavy duty starting with long run up times For separate mounting, suitable for all contactors							
0,8 - 1,2	1,2	-	2,1		1	1,0	
1,2 - 1,8	2,1	-	3,1		UAT21 1,8	1	1,0
1,6 - 2,4	2,8	-	4,2		UAT21 2,4	1	1,0
2,4 - 3,7	4,2	-	6,4	hand reset	1	1,0	
3,7 - 5,7	6,4	-	9,9		UAT21 5,7	1	1,0
5,3 - 8,2	9,2	-	14,2		UAT21 8,2	1	1,0
8 - 12	13,9	-	20,1	hand reset	1	1,0	
12 - 18	20,1	-	31,2		UAT21 18	1	1,0
16 - 24	27,7	-	41,6	UAT22 24	1	1,1	
24 - 37	41,6	-	64	UAT23 37	1	1,3	
32 - 49	55,4	-	85	UAT23 49	1	1,3	
48 - 72	83	-	125	UAT23 72	1	1,3	



Thermal Overload Relays,

tripping times for selection to motors of protection degree EEx e

Relays With Standard Tripping Characteristic

Setting Range Tripping time depending on the multiple of the current setting from cold condition (tolerance $\pm 20\%$ of the tripping time)

A	A	I_A/I_N 3	I_A/I_N 4	I_A/I_N 5	I_A/I_N 6	I_A/I_N 7,2	I_A/I_N 8	
U12/16E ..								
0,12	-	0,18	18,5	10,4	7,2	5,5	4,3	3,6
0,18	-	0,27	16,7	9,8	6,5	5	4,1	3,5
0,27	-	0,4	19,4	12,1	8,2	5,9	4,9	4,2
0,4	-	0,6	18,7	11,2	8	6	4,9	4,1
0,6	-	0,9	19,7	11,6	8,1	6,1	4,9	4,2
0,8	-	1,2	22,9	13,6	10	7,3	6	5,2
1,2	-	1,8	22,2	13,2	9,2	7,6	5,8	5,3
1,8	-	2,7	23	13,7	9,3	7,6	5,7	5,1
2,7	-	4	24	14,4	9,9	7,8	5,9	5,1
4	-	6	24,7	13,8	9,9	7,3	5,6	4,8
6	-	9	22	13,4	8	5,7	4,1	3,5
8	-	11	17,4	9,2	5,9	4,1	2,9	2,3
10	-	14	26,4	12,9	7,6	5,2	3,5	2,8
13	-	18	14,7	7,7	4,8	3,2	2,3	1,7
17	-	23	16,2	8,4	5	3,6	2,4	1,8
22	-	30	16,8	8,5	5	3,6	2,3	1,9
MCOR-2 ..								
10	-	14	21,8	11,4	7	5	3,7	2,8
14	-	20	22,4	11,2	6,7	4,5	3,2	2,4
20	-	28	21,8	10,8	6,5	4,5	3,3	2,5
28	-	42	25,2	13,3	8	5,5	4	3,1
MCOR-3 ..								
20	-	28	21,8	10,8	6,5	4,5	3,3	2,5
28	-	42	25,2	13,3	8	5,5	4	3,1
40	-	52	18,3	9,2	5,6	3,9	2,8	2,2
52	-	65	17,8	8,7	5,2	3,4	2,5	1,9
U85 ..								
60	-	90	19,5	13,5	11	10	9,5	8,5
80	-	120	18	11	10	9	8,5	8
U205 ..								
100	-	150	34	26	24	20,5	19	18
140	-	210	30	24	21	18,5	17	16
U840 ..								
260	-	360	23,3	14,1	10	7,6	6,1	5,4
340	-	480	23	13,8	9,6	7,6	6,1	5,4
440	-	620	20,5	12,4	9	7	5,5	5
560	-	800	21	12,5	9	7	5,6	5,2

When selecting a standard overload, refer to the tripping curve. Determine the values of the starting current ratio I_A/I_N and the time t_E which is marked on the label of the motor. The overload must trip within the t_E time, which means that the tripping curve from cold condition must be (20% due to tolerance) below the co-ordination point I_A/I_N and the time t_E .

I_A = Starting current of motor

I_N = Rated current of motor

t_E = t_E -time of motor

Relays With Quick Tripping Characteristic

preferably for motors with short t_E time and for submersible pumps

Setting Range Tripping time depending on the multiple of the current setting from cold condition (tolerance $\pm 20\%$ of the tripping time)

A	A	I_A/I_N 3	I_A/I_N 4	I_A/I_N 5	I_A/I_N 6	I_A/I_N 7,2	I_A/I_N 8	
U12/16UQ ..								
0,4	-	0,6	13,6	8,4	5,9	4,2	3,3	3
0,6	-	0,9	13,8	7,8	5,2	4,1	3,2	2,7
0,8	-	1,2	13,1	7,5	5,2	3,9	3,1	2,7
1,2	-	1,8	14,6	8,7	6,0	4,6	3,6	3,2
1,8	-	2,7	13,5	7,6	5,3	3,9	3,1	2,7
2,7	-	4	11	6	4,1	2,6	1,7	1,4
4	-	6	9,6	5,3	3,3	2,3	1,6	1,3
6	-	9	10,2	5,4	3,4	2,3	1,6	1,3
8	-	11	12	6,2	3,9	2,5	1,8	1,3
10	-	14	12,8	6,6	4	2,6	1,8	1,4

All tripping times of overload relays U12/16UQ are shorter than the minimum values of the t_E time for motors of protection degree EEx e acc. to EN 50019 and therefore are suitable for all motors of protection degree EEx e. For these overload relays the selection on basis of tripping curves is thereby not necessary.

Time t_E / Tripping time

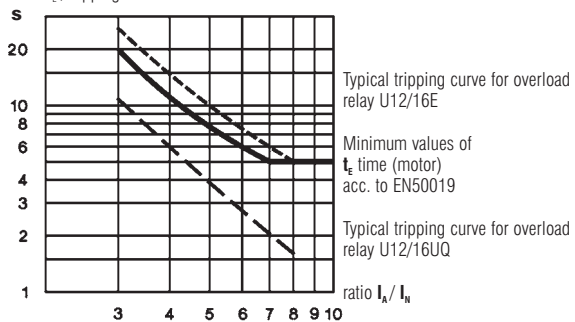

Labels of tripping curves for each setting range, sized 148x105mm (self-adhesive) are available on request.

Order No. D588, specify type and setting range.

Example of selection for thermal overload relay:

Technical data of a motor protection EEx e

$P_N = 1,5kW$ $I_N = 3,6A$ $I_A/I_N = 5$ t_E time = 8s

1) U12/16E 4 (2,7 - 4A)

Tripping time at $5 \times I_N = 9,9s$

$9,9s + 20\%$ tolerance = **11,9s** > $t_{E \text{ Motor}} = 8s$

The device U12/16E 4 is **not suitable**.

2) U12/16UQ 4 (2,7 - 4A)

Tripping time at $5 \times I_N = 4,1s$

$4,1s + 20\%$ tolerance = **4,9s** < $t_{E \text{ Motor}} = 8s$

The device U12/16UQ 4 is therefore suitable for motor protection

Thermal Overload Relays



Fuses for MCOR-1, MCOR-2, MCOR-3, U12/16E, U85, U310, U205, U840 and U1250

Type	Setting Range		Y Δ		Max. Fuse Size According to Coordination-type			Fuse UL		
	DOL	A	A	A	"2" ¹⁾ quick A	slow, gL(gG) A	"1" ¹⁾ slow, gL(gG) A	aM A	A	
MCOR-1 U12/16E	0,12	-	0,18	-	0,5 ²⁾	0,5 ²⁾	25	-	15	
	0,18	-	0,27	-	1,0 ²⁾	1,0 ²⁾	25	-	15	
	0,27	-	0,4	-	2	2	25	-	15	
	0,4	-	0,6	-	2	2	25	-	15	
	0,6	-	0,9	-	4	4	25	-	15	
	0,8	-	1,2	-	4	4	25	2	15	
	1,2	-	1,8	-	6	6	25	2	15	
	1,8	-	2,7	-	10	10	25	4	15	
	2,7	-	4	-	16	10	25	4	15	
	4	-	6	7	10,5	20	16	25	6	15
6	-	9	10,5	15,5	35	25	35	10	25	
8	-	11	14	19	35	25	35	16	30	
10	-	14	18	24	50	35	63	16	40	
13	-	18	23	31	50	35	63	20	50	
17	-	23(24)	30	40(41)	63	50	63	25	60	
	22(23)	-	30(32)	38(40)	52(55)	80	63	80	35	70
MCOR-2	10	-	14	18	24	50	35	80	16	40
	14	-	20	24	35	63	50	80	25	60
	20	-	28	35	48	80	63	80	35	80
28	-	42	48	52	100	80	150	50	110	
MCOR-3	20	-	28	35	48	100	80	150	35	80
	28	-	42	48	73	125	100	150	50	110
	40	-	52	70	90	160	100	150	63	200
52	-	65	90	112	160	125	150	80	250	
U85	60	-	90	104	156					300
	80	-	120	140	207					-
U205	all ranges				For short circuit protecting overload relays with current transformer use fuse according to the contactor of the combination.				-	
U310, U840	all ranges								-	
U1250	all ranges								-	

Values in brackets for MCOR-1

Tripping Characteristics for MCOR-1, MCOR-2, MCOR-3 and U12/16E

Detailed tripping times for each range see table page 105

with three-phase load

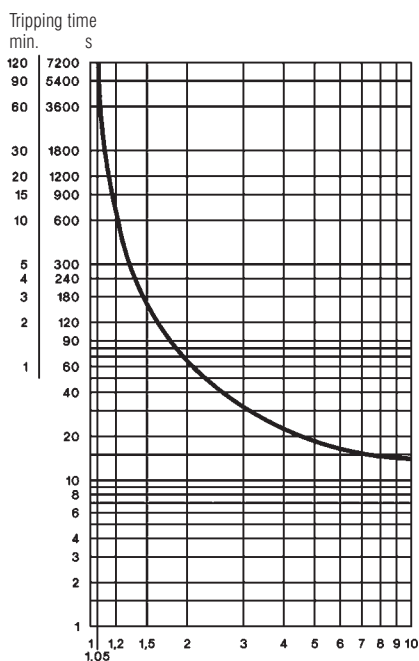

Average value of typical tolerance curves from cold condition

Proceeding from service condition the times decrease to 20-30% of the characteristic values

F. L. C. multiplication factor

with two-pole load

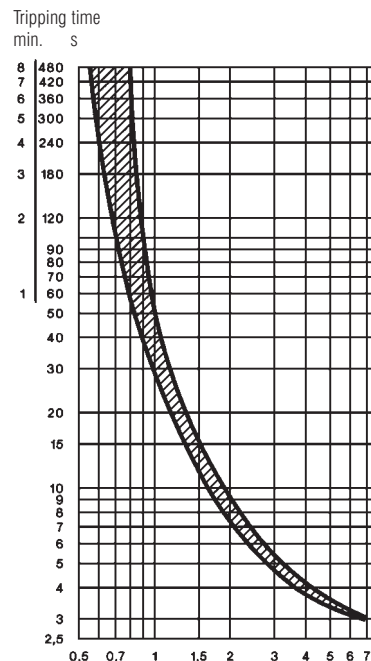

Typical tolerance curve from cold condition

Proceeding from service condition the times decrease to 70-80% of the characteristic values

$K = I_{max} / I_e$

I_{max} = max. phase current
 I_e = max. scale value

1) Coordination-type according to IEC 947-4-1:
"2": Light contact welding accepted. Thermal overload relay must not be damaged.
"1": Welding of contactor and damage of the thermal overload relay allowed.
2) Miniature fuse

Thermal Overload Relays

Tripping Characteristics for U85, U205, U310, U840 and U1250

Detailed tripping times for each range of U85 and U205 see table page 105

U85 with three-phase load

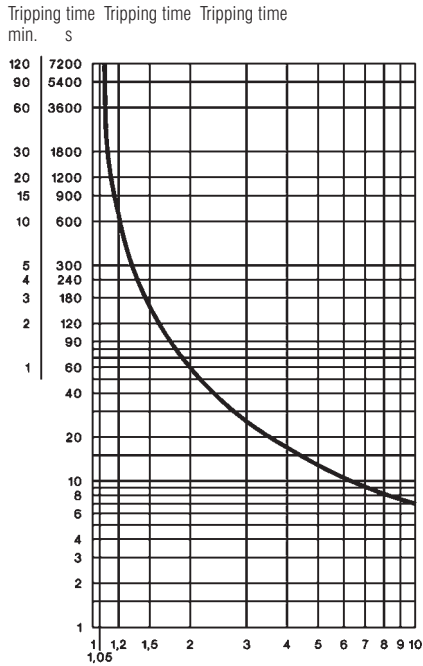

U205 with three-phase load

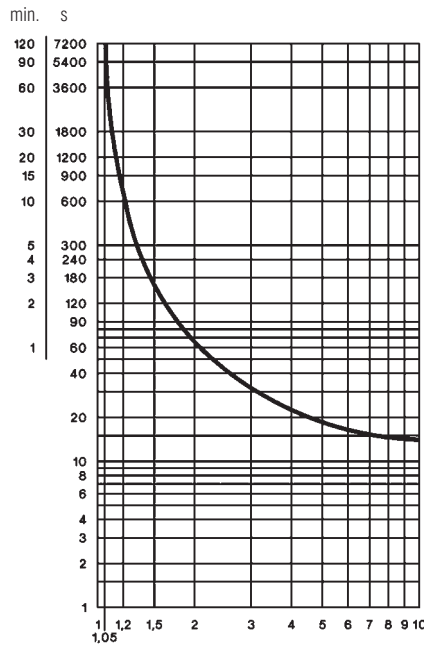

U310, U840 with three-phase load

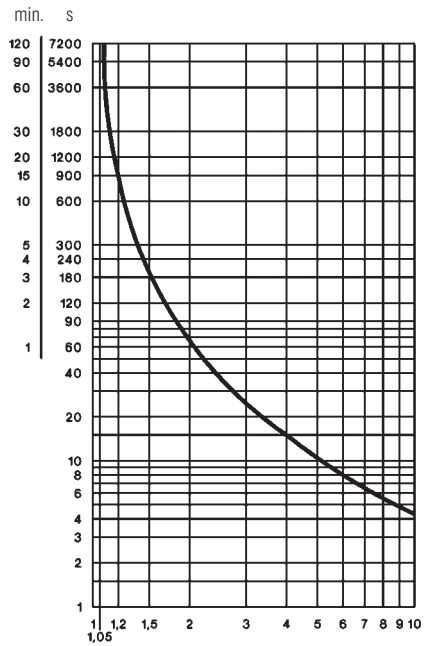

F. L. C. multiplication factor

Average value of typical tolerance curves from cold condition
Proceeding from service condition the times decrease to 20-30% of the characteristic values

U85 with two-pole load

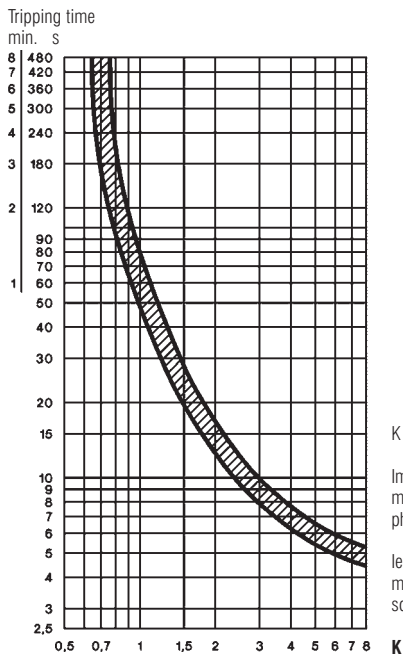

U205 with two-pole load

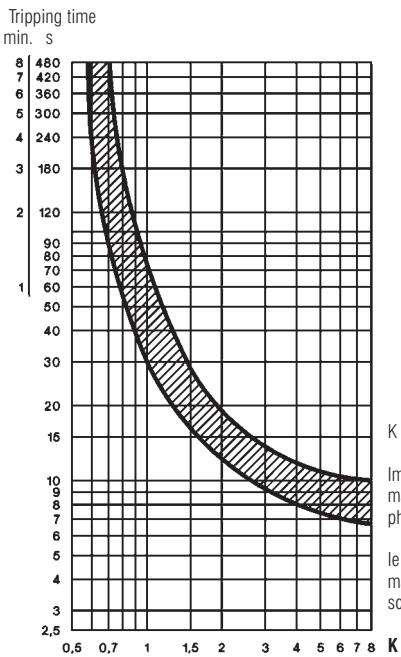

$K = I_{max} / I_e$
 I_{max} = maximum phase current
 I_e = maximum scale value

$K = I_{max} / I_e$
 I_{max} = maximum phase current
 I_e = maximum scale value

U1250 with three-phase load

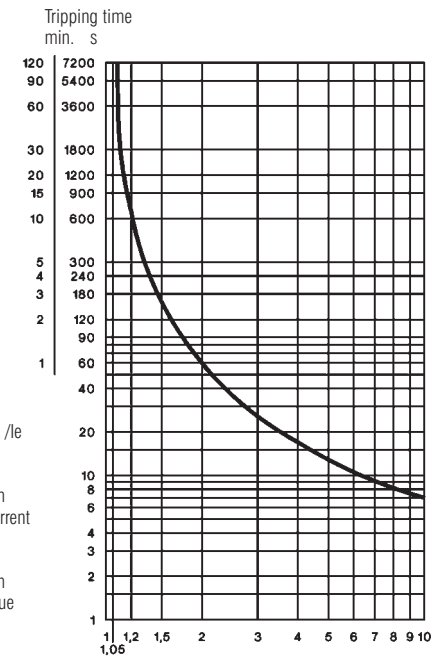

Typical tolerance curve from cold condition
Proceeding from service condition the times decrease to 70-80% of the characteristic values

F. L. C. multiplication factor

Proceeding from service condition the times decrease to 20-30% of the characteristic values

Position of Terminals

MCOR-1

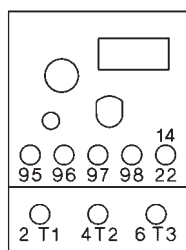

U12/16E, U12/16EM

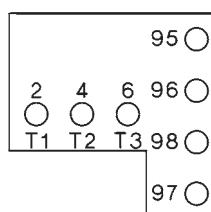

U12/16UQ

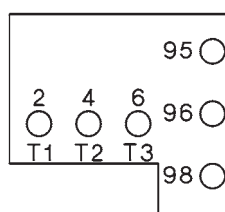

MCOR-2, MCOR-3

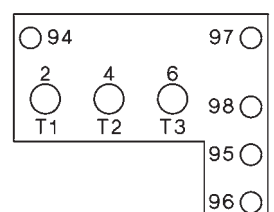

Thermal Overload Relays in Special Version



Fuse for U12/16UQ

Setting Range	Maximum Fuse Acc. to Coordination-type "2" 1)		
	quick A	slow, gL(gG) A	slow, gL(gG) A
0,4 - 0,6 - 0,8	0,6 0,9 1,2	2 4 4	25 25 25
1,2 - 1,8 - 2,7	1,8 2,7 4	6 10 16	6 10 10
4 - 6 - 8	6 9 11	20 35 35	16 25 25
10	14	50	35

Fuse for U12/16EM

Setting Range	Maximum Fuse Acc. to Coordination-type "2" 1)		
	380-400V slow, gL(gG) A	500V slow, gL(gG) A	660-690V slow, gL(gG) A
0,12 - 0,18 - 0,27	none none none	none none none	on request on request on request
0,4 - 0,6 - 0,8	none none none	none none 10	on request on request on request
1,2 - 1,8 - 2,7	none 20 35	16 20 35	on request on request on request

Tripping Characteristic for U12/16UQ

Detailed tripping times for each range see table page 105

with three-phase load

Tripping time range 0,4-0,6 to 1,8-2,7A
min. s

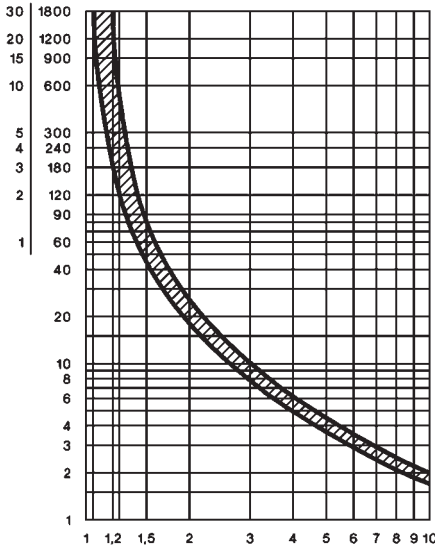

Typical tolerance curve from cold condition
Proceeding from service condition the times decrease to 20-30% of the characteristic values

F. L. C. multiplication factor

Tripping time range 2,7-4 to 10-14A
min. s

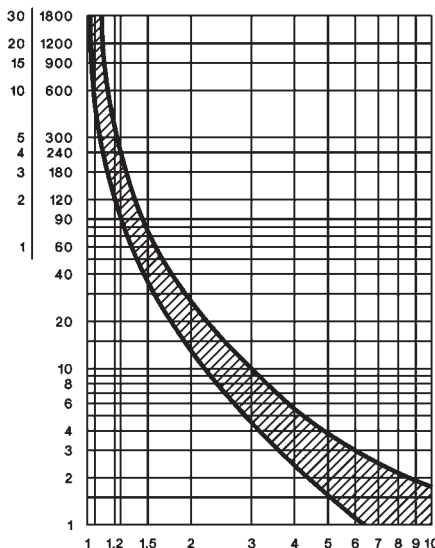

Average value of typical tolerance curves from cold condition
Proceeding from service condition the times decrease to 20-30% of the characteristic values

F. L. C. multiplication factor

Tripping Characteristic for U12/16EM

with three-phase load

Tripping time range 0,12-0,27 to 0,4-1,2A
min. s

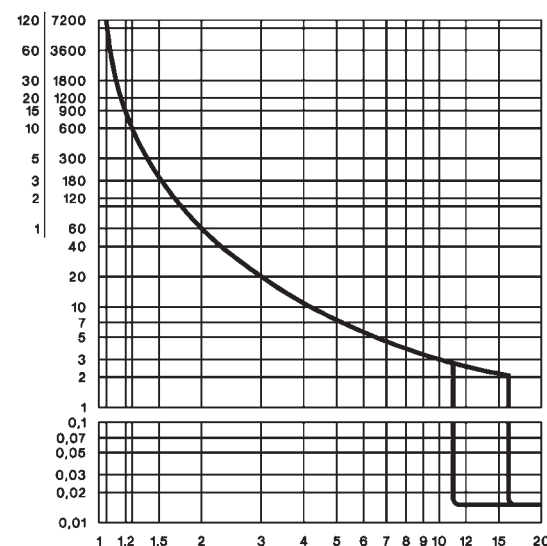

Average value of typical tolerance curves from cold condition
Proceeding from service condition the times decrease to 20-30% of the characteristic values

F. L. C. multiplication factor

Fuse for UAT21, UAT22, UAT23

For short circuit protecting thermal overload relays with current transformer use fuse according to the contactor of the combination.

Tripping characteristic for UAT21, UAT22, UAT23

with three-phase load

Tripping time in s

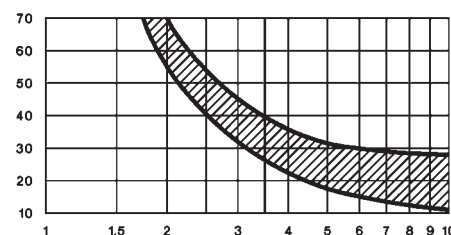

Average value of typical tolerance curves from cold condition
Proceeding from service condition the times decrease to 20-30% of the characteristic values

F. L. C. multiplication factor

1) Coordination-type according to IEC 947-4-1:
"2": Light contact welding accepted. Thermal overload relay must not be damaged.
"1": Welding of contactor and damage of the thermal overload relay allowed.

Thermal Overload Relays

Data according to IEC 947-4-1, IEC 947-5-1, VDE 0660, EN 60947-4-1, EN 60947-5-1

Type	MCOR-1	U12/16 ⁹⁾	MCOR-2	MCOR-3	U85	U205	U310	U840	U1250	UAT21	UAT22	UAT23	
Rated insulation voltage U_i ¹⁾ V~	690	690	690	690	750	690	1000	1000	690	690	690	690	
Permissible ambient temperature operation °C storage °C	-25 to +60 -50 to +70						-25 to +55 -40 to +70		-25 to +60 -50 to +70				
Trip class according to IEC 947-4-1	10A	10A	10A	10A	20	20	10	10	10	30	30	30	
Cable cross-section main connector solid or stranded mm ² flexible mm ² flexible with multicore cable end mm ² Cables per clamp number	0,75-6 1-4 0,75-4	0,75-6+0,75-2,5 ²⁾ 0,75-4+0,5-2,5 ²⁾ 0,5-2,5+0,5-1,5	0,75-10 0,75-6 0,75-6	4-35 ²⁾ 6-25 ²⁾ 4-25	3)	7)		7)	-	0,5-10 0,5-6 0,5-6	0,5-16 0,5-10 0,5-10	0,5-25 0,5-16 0,5-16	2 1 1
auxiliary connector solid mm ² flexible mm ² flexible with multicore cable end mm ² Cables per clamp number	0,75-2,5 ²⁾ 0,5-2,5 ²⁾ 0,5-1,5 2						1-2,5 ²⁾ 1-2,5 ²⁾ 1-2,5 ²⁾ 2		0,75-2,5 ²⁾ 0,5-2,5 ²⁾ 0,5-1,5 2				
Type	MCOR-1	U12/16A	U12/16E U12/16EM	U12/16UQ	MCOR-2 MCOR-3	U85 U205	U310 U840 U1250	UAT21 UAT22 UAT23					
Auxiliary contacts													
Auxiliary contacts Rated insulation voltage U_i ¹⁾ same potential V~ different potential V~	690 440	690 -	690 440	690 -	690 250	690 440	500 500	690 440					
Utilization category AC15 Rated operational current I _e 24V A 230V A 400V A 690V A	3 2 1 0,5	4 2,5 1,5 0,6	5 3 2 0,6	5 3 2 0,6	4 ⁴⁾ 2,5 1,5 0,6	5 3 2 0,6	4 5) 2,5 1,5 0,6	5 3 2 0,6					
Utilization category DC13 Rated operational current I _e 24V A 110V A 220V A	1 0,15 0,1	1,2 0,15 0,1	1,2 0,15 0,1	1,2 0,15 0,1	1,2 0,15 0,1	1,2 0,15 0,1	1,2 0,15 0,1	1,2 0,15 0,1					
Short circuit prot. (without welding 1kA) highest fuse rating gL (gG) A	4	4	6	6	6	6	6	6					
Type	MCOR-1	U12/16	U12/16E	MCOR-2	MCOR-2	MCOR-3	MCOR-3	U85					
Setting range	all	to 23A	22 - 30A	to 28A	28 - 42A	to 52A	52 - 65A	all					
Power loss per current path (max.) minimum setting value W maximum setting value W	1,1 2,3	1,1 2,3	1,7 3,7	1,3 2,6	1,3 3,3	2,0 3,7	2,9 4,5	1,1 2,5					

Data according to cULus

Type	MCOR-1	U12/16A	U12/16E	U12/16UQ	MCOR-2	MCOR-3	U85
Rated insulation voltage V~	600	600	600	600	600	600	600
Rated current A	32	23	23	23	42	74	85
Auxiliary contacts Rated voltage same potential V AC different potential V~	600 150	600 -	600 150	600 -	600 150	600 150	600 150
Switching capacity AC of aux. contacts VA A	500 2	500 3	500 4	500 4	600 8) 4	600 8) 4	600 4

Temperature Compensation

In case of higher ambient temperature use the following formula:
(Ambient temperature - 20) x 0,125 = correction factor in %
of the full load motor current

Example: Ambient temperature 70°C, full load motor current 7A
(70 - 20) x 0,125 = 6,25%
Setting value: 7A + 6,25% = 7,44A

1) Suitable for: earthed-neutral systems, overvoltage category I to III, pollution degree 3 (standard-industry): U_{imp} = 4kV (at 440V), 6kV (at 690V).

Data for other conditions on request.

2) Maximum cable cross-section with prepared conductor

3) Without terminals, suitable for bushing one connector 70mm (stranded) per phase

4) Switching capacity of the start contact: AC15 300VA, max. 1,5A, DC13 (max. 220V) 30W, max. 1,5A

5) Switching capacity of the make contact: AC15 400VA, max. 1,7A, DC13 (max. 220V) 10W, max. 1A

6) U12/16E 30: Cable cross-section for main connector like type U3/42, one connector only

7) Busbar sets see accessories page 103

8) Switching capacity of the start contact: 300VA, max. 2A

Thermal Overload Relays

Dimensions

MB09 + **U12/16E**
MB12

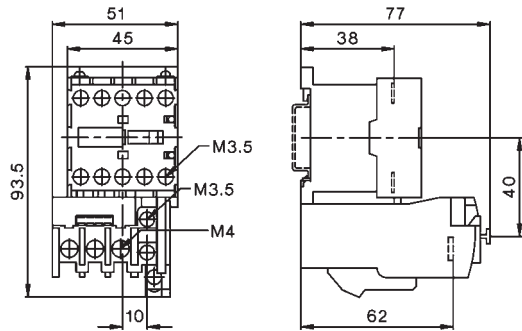

KG2-09 + **U12/16**
KG2-12
KG2-16

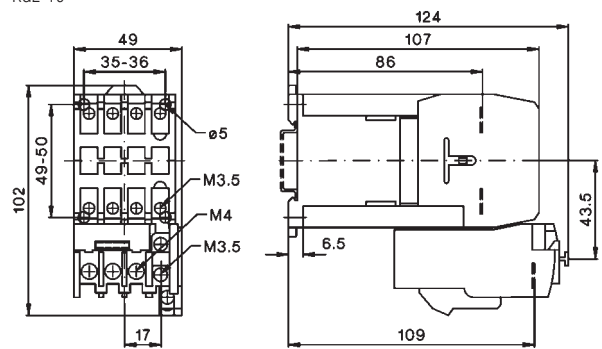

MC10 + **MCOR-1**
MC14
MC18
MC22

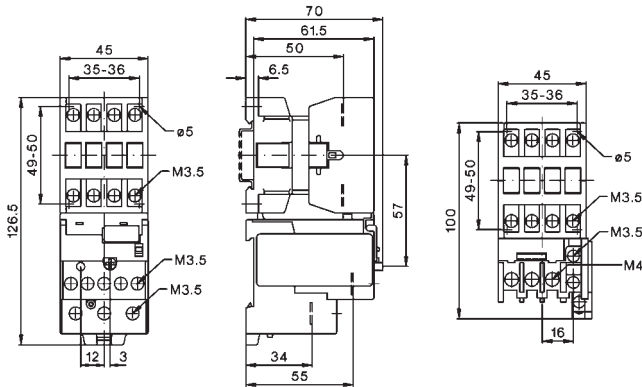

MC10 + **U12/16**
MC14
MC18
MC22

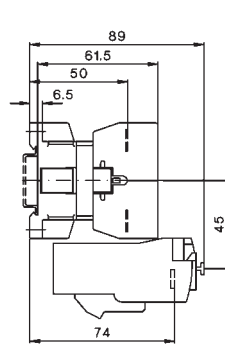

MC24 + **MCOR-2**
MC32
MC40

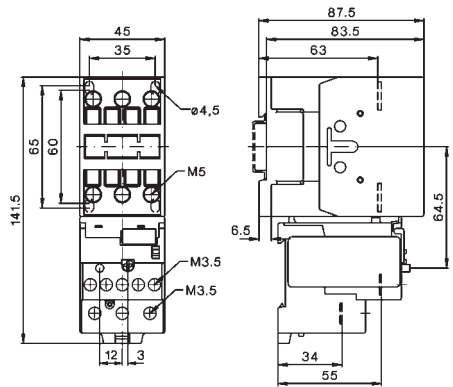

MC24 + **MCOR-2**
MC32
MC40

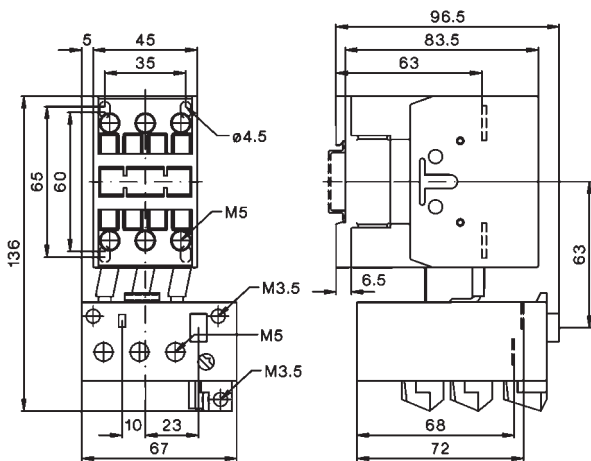

MC50 + **MCOR-3**
MC62
MC74

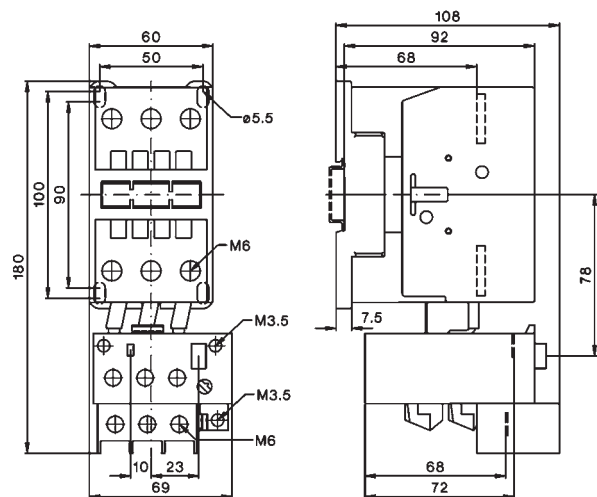

U3/32SM

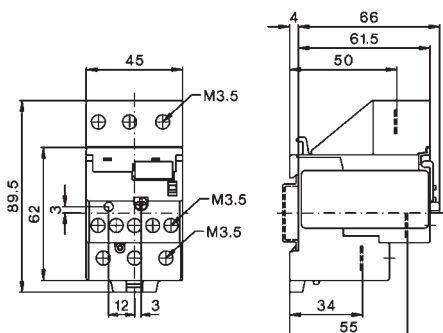

U3/42G

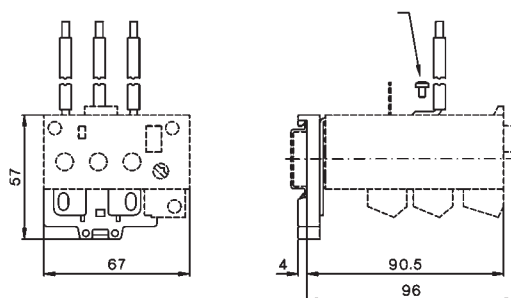

Thermal Overload Relays

Dimensions

K85 + U85
K110

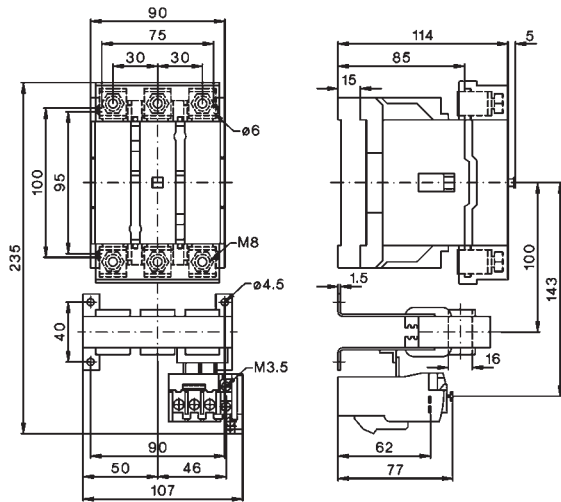

K3-150A11 + U205
K3-175A11

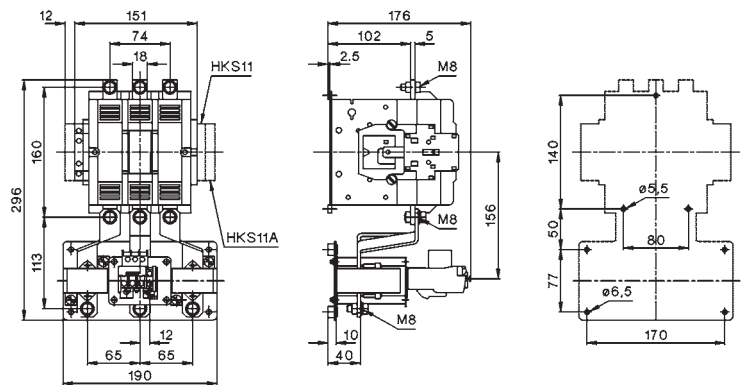

K3-200A11 + U205

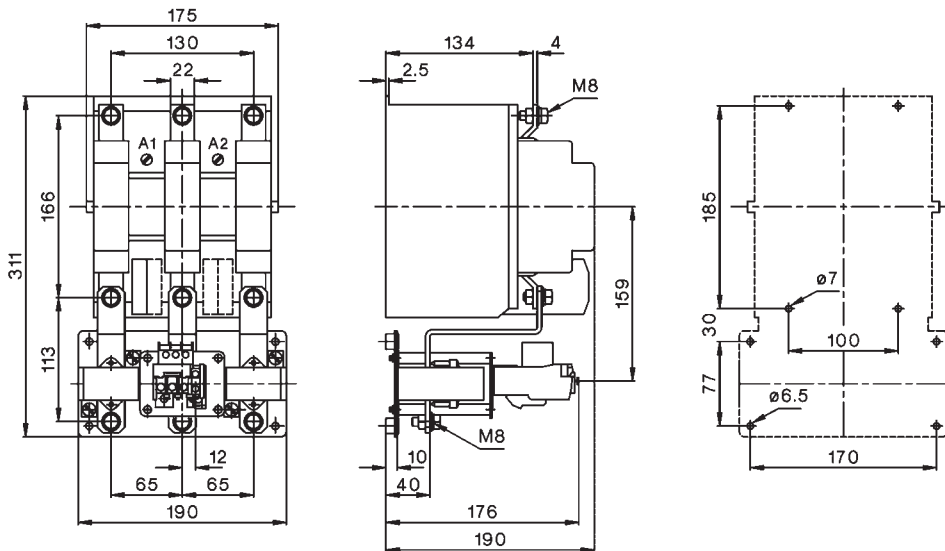

K3-315A11 + U310

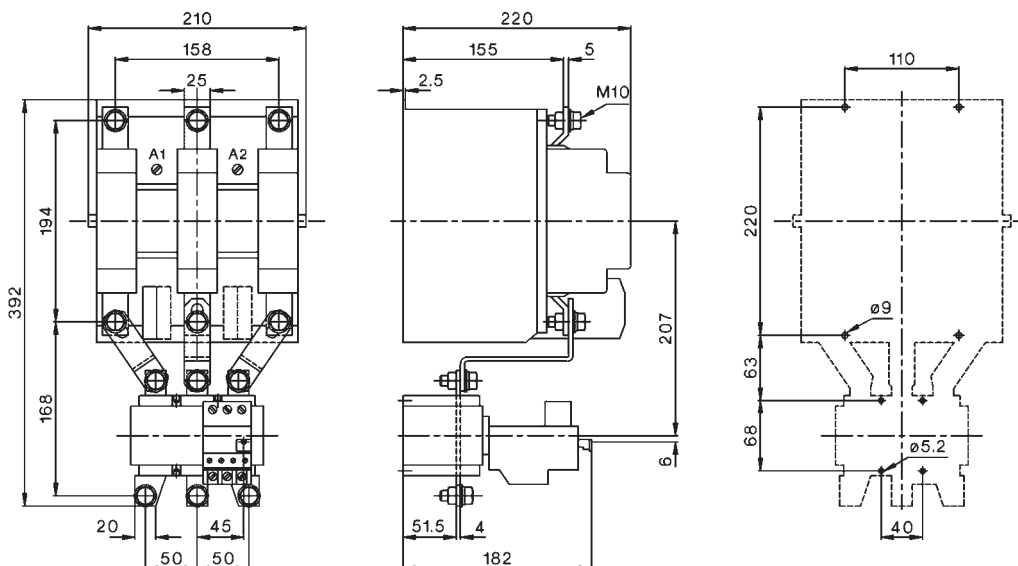

Thermal Overload Relays

Dimensions

U840

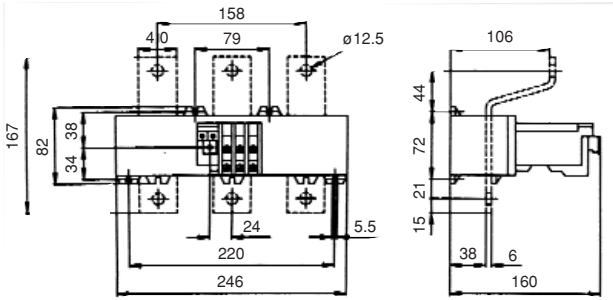

U1250

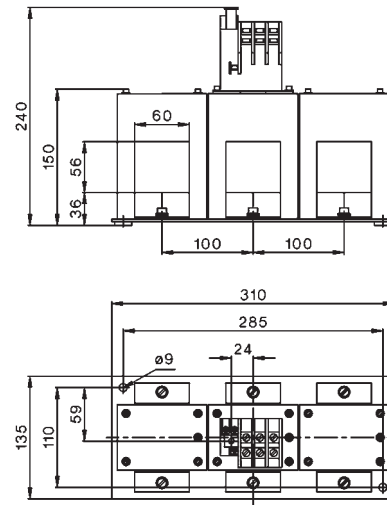

U840 with A	B	C	D	E	F	G	H	J	K	
K3-315	210	366	110	220	158	40	179	220	12,5	9
K3-450	220	372	110	220	158	40	185	225	12,5	9
K3-550	220	395	110	220	158	40	196	225	12,5	9
K3-700	280	487	175	280	202	50	257	291	14,5	11
K3-860	280	540	175	280	202	50	280	291	14,5	11

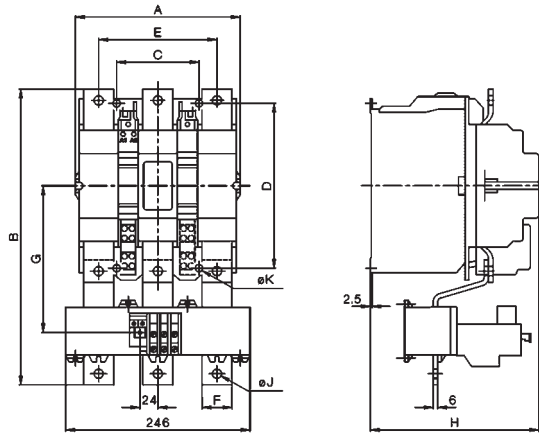

U12SM

U12/16 + U12SM for snap-on 35mm DIN-rail according to DIN EN50022 and screw mounting (single mounting)

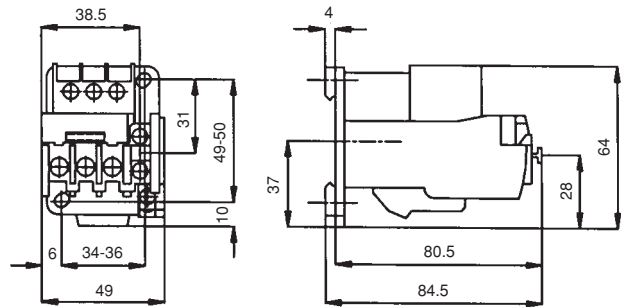

UAT21

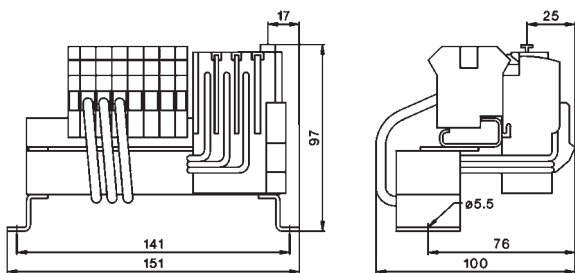

UAT22

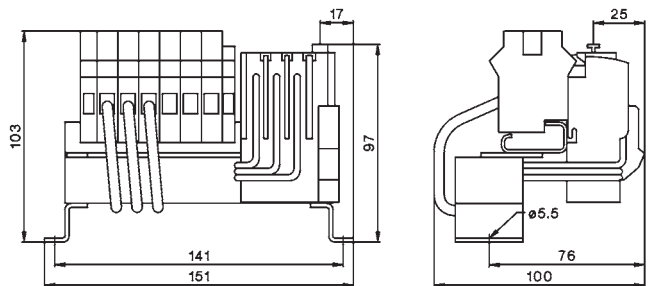

UAT23

Type	Setting Range	A	B
UAT23 37	23-37A	105,5	97,5
UAT23 49	32-49A	94	86
UAT23 72	48-72A	94	86

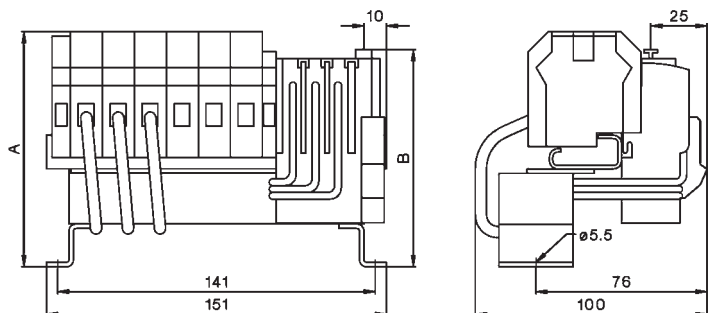



IMO Precision Controls Limited
1000 North Circular Road
Staples Corner, London NW2 7JP
United Kingdom

Tel: +44 (0)208 452 6444

Fax: +44 (0)208 450 2274

Web: www.imopc.com

Email: imo@imopc.com