



...Display, Control, Communicate



Tutorial

Modbus Slave

Table of Contents

TABLE OF CONTENTS	2
INTRODUCTION.....	3
<i>I</i>³ MODBUS MAP	4
PROTOCOL CONFIGURATION.....	5
PROGRAMMING EXAMPLE	6
LADDER LOGIC PROGRAMMING	6
SCREEN EDITOR PROGRAMMING.....	7
PMU PROGRAMMING	7
<i>PMU - i</i> ³ <i>screens</i>	9
WIRING DIAGRAM	11
MJ2 PINS.....	11
RUNNING THE PROGRAM.....	11

Introduction

The purpose of this tutorial is to demonstrate the Modbus slave communication functions of the i^3 .

In this tutorial we will demonstrate the i^3 as a Modbus slave with a HMI connected to the i^3 controlling it. The advantage of having the capability of connecting to an external HMI allows data to be represented in different aspects in another location.

To demonstrate the connection between an i^3 and a HMI we will connect an i^3 to a PMU. This gives us the advantage of being able to provide the user with another and more graphical interface.

***i*³ Modbus Map**

Modbus Master Mapping					
Internal Reference	Maximum Range	Traditional Modbus Reference	Expanded Modbus Reference	Modbus Command(s)	Modbus Offset
%Q1	2048	00001	000001	Read Coil Status (1) Force Single Coil (5) Force Multiple Coils (15)	00000
%M1	2048	03001	003001		03000
%T1	2048	06001	006001		06000
%QG1	256	09001	009001		09000
<hr/>					
%I1	2048	10001	100001	Read Input Status (2)	00000
%IG1	256	13001	103001		03000
%S1	256	14001	104001		04000
%K1	256	15001	105001		05000
<hr/>					
%AI1	512	30001	300001	Read Input Register (4)	00000
%AIG1	32	33001	303001		03000
%SR1	32	34001	304001		04000
<hr/>					
%AQ1	512	40001	400001	Read Holding Registers (3) Preset Single Register (6) Preset Multiple Registers (16)	00000
%R	9999	(Previously 43001 for 2048 registers)	410001		03000
%AQG1	32	46001	406001		06000
					10000

Protocol Configuration

Unlike with the master setting there is no protocol to set up before programming the ladder logic. The Modbus slave configuration is completely set up in Ladder logic.

Programming Example

In this tutorial we are going to demonstrate the screens on the *i*³ demonstration program on a Graphical PMU330TT.



The *i*³ program will be very straightforward, we are just going to add the Modbus slave function to the demonstration program.

The PMU program will be programmed to display a similar screen to the screen showing on the *i*³.

Ladder Logic Programming

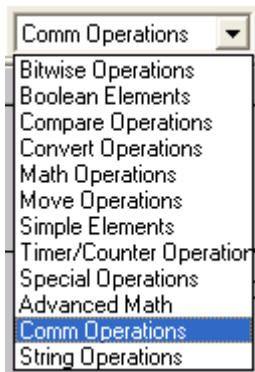
Using the program i3_demo_prog.csp add to the program the Modbus slave function and Open Port function.



Select from the Communication Operations the Open Communication Port function icon , insert it into a rung with an 'Always On' contact. Now select a Modbus slave function icon  and insert it into the same rung.

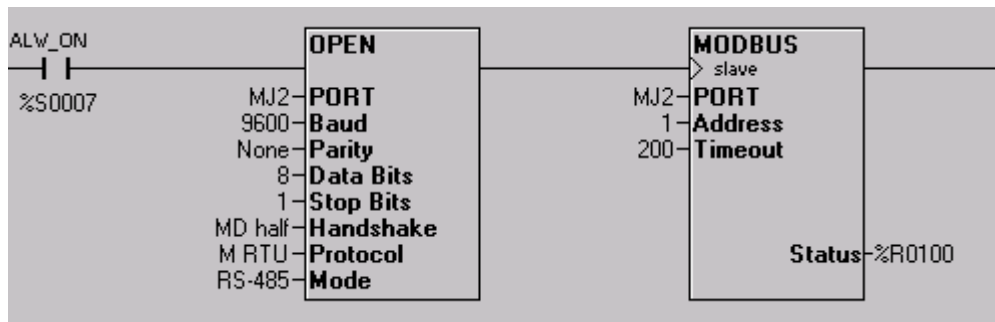

Double click on the functions and insert the parameter details as shown. This Port Open function Opens the selected port and designates a protocol to it. The Modbus slave function defines the slave's address and a status register so that the communication link status can be viewed.

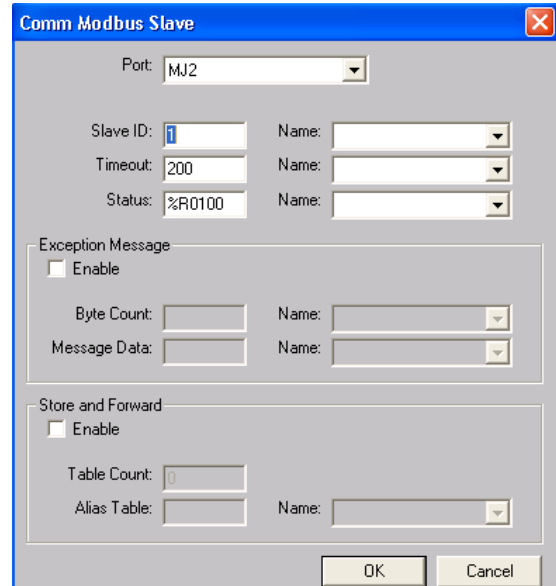
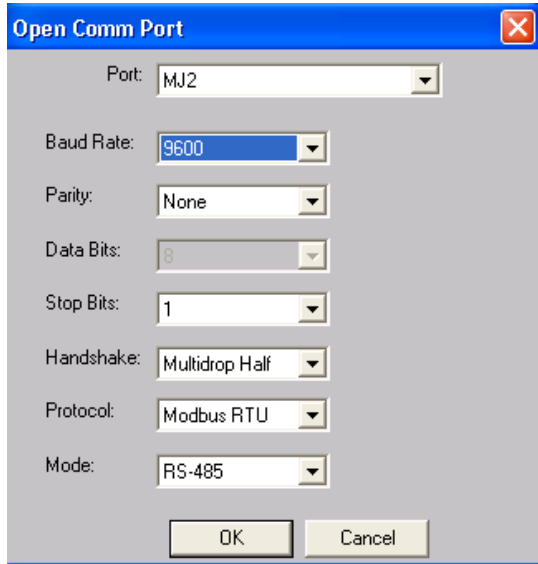

Screen Editor Programming

The screen editor program will be exactly the same as in the demo program.

PMU Programming

The PMU screens will change as the i^3 screens change and display a similar screen to that on the i^3 . Please refer to the PMU Training manual for programming instructions on the PMU.

The PMU addresses will refer to the Modbus reference of the registers in the i^3 .

Modbus Slave

Screen	Address	Modbus reference Address
2	Timer PV - %R3	43003
2	Timer CV - %R7	43007
2	Bar Graph - %R7	43007
3	Lamp - %M1	03001
3	Meter - %R9	43009
3	CV - %R9	43009
3	PV - %R11	43011
4	Message - %R4	43004
5	Graph - %R7	43007
5	Up - %K6	15006
5	Reset - %K10	15010
6	Keys - %K1 to %K4	15001 to 15004
7	Alarm - %R4	43004
8	Inputs - %I1 to %I4	10001 to 10004

PMU - *i*³ screens

I:1

*i*³ Display
Control
Communicate

YYYY/MM/DD HH:MM:SS

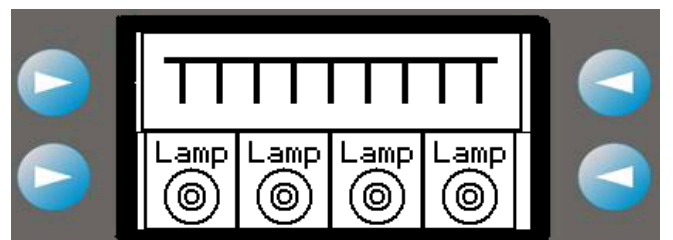
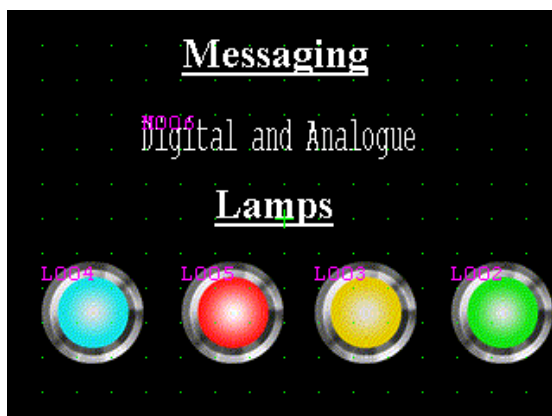
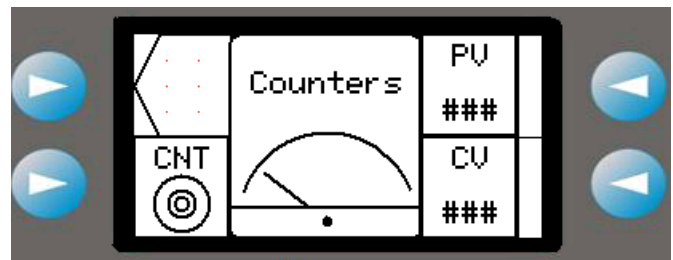
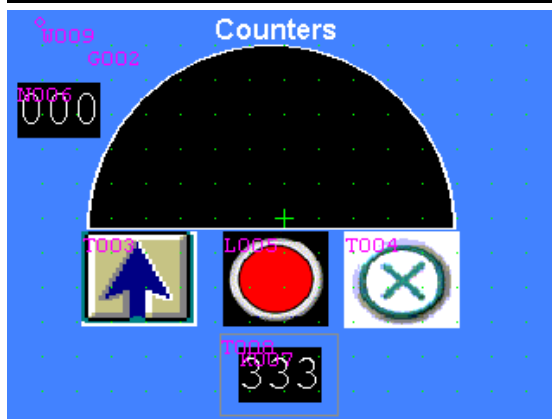
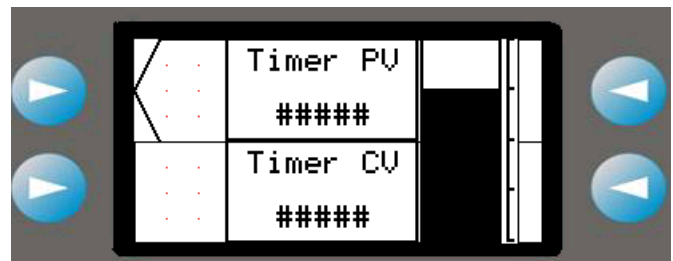
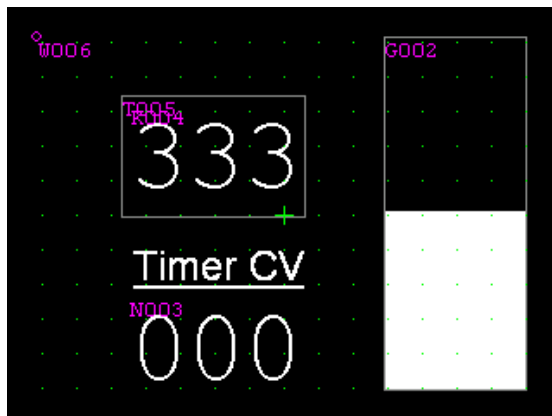
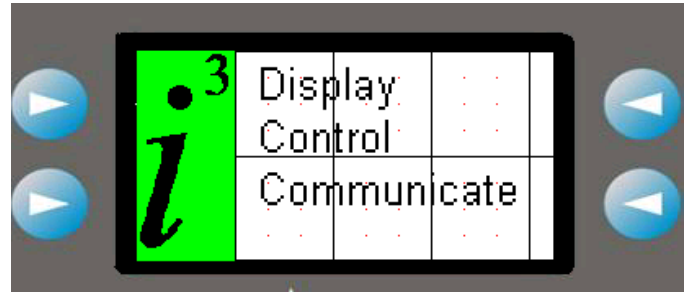

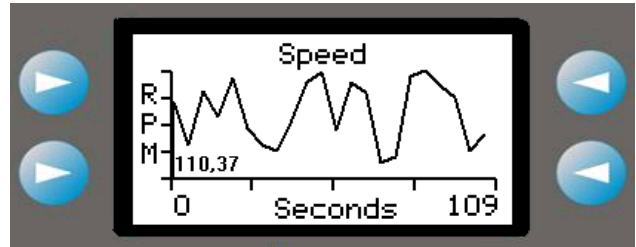
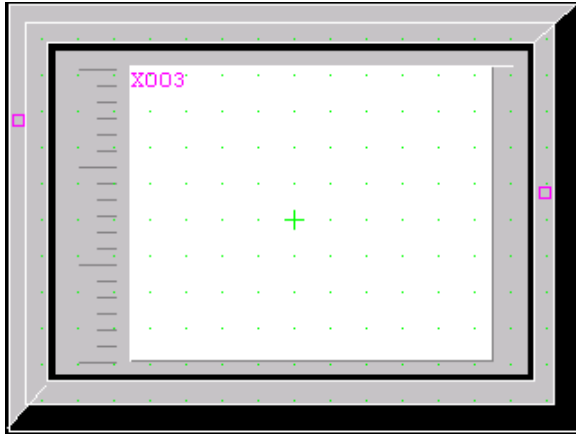

Function Keys

T002

T003

T004

T005

L005

L007

L008

L009

Function Keys

K1	k2	k3	k4

Alarms and Logging

```

LOG#
mm/dd HH:MM:SS AAAAAAAAAAAAAAAAAAAAAAAAAAAAA
mm/dd HH:MM:SS AAAAAAAAAAAAAAAAAAAAAAAAAAAAA
mm/dd HH:MM:SS AAAAAAAAAAAAAAAAAAAAAAAAAAAAA
mm/dd HH:MM:SS AAAAAAAAAAAAAAAAAAAAAAAAAAAAA
mm/dd HH:MM:SS AAAAAAAAAAAAAAAAAAAAAAAAAAAAA
mm/dd HH:MM:SS AAAAAAAAAAAAAAAAAAAAAAAAAAAAA
mm/dd HH:MM:SS AAAAAAAAAAAAAAAAAAAAAAAAAAAAA
mm/dd HH:MM:SS AAAAAAAAAAAAAAAAAAAAAAAAAAAAA
mm/dd HH:MM:SS AAAAAAAAAAAAAAAAAAAAAAAAAAAAA
    
```

Alarms & Logging

mm/dd HH:mm ACT

mm/dd HH:mm ACK

mm/dd HH:mm RTN

Inputs / Outputs

12 or 24 Digital Inputs. NPN or PNP
 Relay (6) or Transistor (12/16) outputs
 1, 2 or 4 Analogue Inputs (0(4)-20mA /0-10V)
 Thermocouple / RTD Inputs
 4 Channel 20kHz HSC
 2 PWM Outputs (10kHz)
 Remote I/O Stations

I1

I2

I3

I4

Inputs

I1	I2	I3	I4

Wiring Diagram

We are using Port 2 on the i^3 as a RS485, 2 wire, twisted-pair to connect to the PMU330TT. The wiring for this is as follows.

Port 2 connections.

Pin	MJ2 Pins	
8	TXD	OUT
7	RXD	IN
6	0 V	Gnd
5	N/C	N/C
4	TX-	OUT
3	TX+	OUT
2	RX-	IN
1	RX+	IN

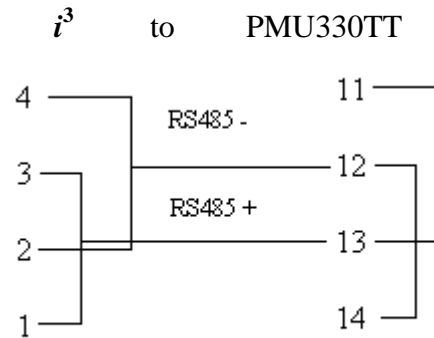

This wiring has the advantage that both the PMU and i^3 can still have their programming ports connected, thus making debugging easier.

Remember to connect the RS-485 termination jumper as shown

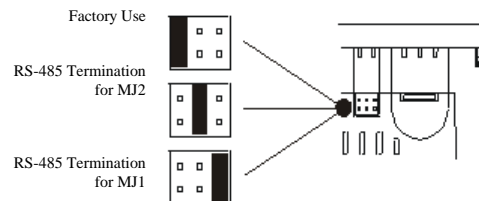

Running the Program

Please connect the i^3 and PMU as shown and use the programs:

i^3 : `i3_demo_prog_pmu.csp`

PMU : `i3_demo_prog.PMU`

As the user scrolls through the screens on the i^3 the PMU screens will change in synch. The user will also be able to enter data on the PMU and change the values in the i^3 .



IMO Precision Controls Limited
 1000 North Circular Road
 Staples Corner, London
 NW2 7JP United Kingdom
 Tel: +44 (0)20 8452 6444
 Fax: +44 (0)20 8450 2274
 Email: imo@imopc.com
 Web: www.imopc.com



IMO Jeambrun Automation SAS
 165 Rue Jean Jaures,
 94700 Maisons Alfort
 Paris, France
 Tel: +33 (0)1 45 13 47 05
 Fax: +33 (0)1 45 13 47 37
 Email: info@imopc.fr
 Web: www.imopc.fr



IMO Deutschland
 Für weitere Einzelheiten
 zu IMO Agenten und
 Distributoren in Ihrer Nähe
 schreiben. Sie bitte ein E-mail
 an folgende Adresse:
 imo@imopc.com



IMO Italia
 Viale A. Volta 127/a
 50131 Firenze, Italia
 Tel: +39 800 783281
 Fax: +39 800 783282
 Email: info@imopc.it
 Web: www.imopc.it



IMO Canada
 Unit 10, Whitmore Road
 Woodbridge, Ontario.
 L4L 8G4 Canada
 Tel: +1 905 265 9844
 Fax: +1 905 265 1749
 Email: imocanada@imopc.com



Cam Switches
 Din Terminals
 Drives
 Enclosures
 Fieldbus remote I/O
 Isolators & Switch Fuses
 MCB & RCD
 Motor Circuit Breakers
 Motor Control Gear
 Panel Meters
 Relays
 Signal Conditioning
 Sockets
 Timers
 Transformers &
 Power Supplies



Drives
 Intelligent Terminals/HMI
 Limit Switches
 Photoelectric Switches
 PLCs
 Proximity Switches
 Temperature Controls



Data Acquisition & Control
 Drives
 Intelligent Terminals/HMI
 Limit Switches
 Photoelectric Switches
 Proximity Switches
 PLCs
 Signal Conditioning
 Temperature Controls



Lightguards
 Safety Limit Switches
 Safety Relays



Jaguar VXM 0.37-500KW
 Jaguar VXSM 0.37-7.5KW
 Jaguar CUB 0.37-2.2KW



Audible devices
 Chip-on-Board
 Device programmers
 LEDs & 7 seg. displays
 PCB Terminal blocks
 Relays - automotive
 Relays - power
 Relays - signal
 Switches

All IMO products are tried, tested and approved
 to relevant international quality standards

