



**INDUSTRIAL
CONTROL DIRECT**

A BSD Industrial Company

Instruction Manual
High Performance Inverter

IMO Jaguar VXT



⚠ CAUTION

Thank you for purchasing our Jaguar VXT series of inverters.

- This product is designed to drive a three-phase induction motor. Read through this instruction manual and be familiar with the handling procedure for correct use.
- Improper handling might result in incorrect operation, a short life, or even a failure of this product as well as the motor.
- Deliver this manual to the end user of this product. Keep this manual in a safe place until this product is discarded.
- For how to use an optional device, refer to the instruction and installation manuals for that optional device.

Copyright © 2017 IMO Precision Controls Ltd

All rights reserved.

No part of this publication may be reproduced or copied without prior written permission from IMO Precision Controls Ltd.

All products and company names mentioned in this manual are trademarks or registered trademarks of their respective holders.

The information contained herein is subject to change without prior notice for improvement.

Preface

Thank you for purchasing our multifunction Jaguar VXT series of inverters. This product is designed to drive a three-phase induction motor or a three-phase permanent magnet synchronous motor under variable speed control.

This manual provides all the information on the Jaguar VXT series of inverters including its operating procedure and selection of peripheral equipment. Before use, carefully read this manual for proper use. Improper handling might result in incorrect operation, a short life, or even a failure of this product as well as the motor.

The table below lists the other materials related to the use of the Jaguar VXT. Read them in conjunction with this manual if necessary.

Name	Description
Catalog	Product scope, features, specifications, external drawings, and options of the product
Jaguar VXT User's Manual	Product details control block diagrams, specifications, and external dimensions
RS-485 Communication User's Manual	Overview of functions implemented by using Jaguar VXT RS-485 communications facility, its communications specifications, Modbus RTU/IMO general-purpose inverter protocol, function codes and related data formats

The materials are subject to change without notice. Be sure to obtain the latest editions for use.

CONTENTS



Chapter 1	BEFORE USE	
1.1	Acceptance Inspection (Nameplates and Inverter Type).....	1-1
1.2	External View and Terminal Blocks.....	1-3
1.3	Precautions for Using Inverters.....	1-5
1.3.1	Usage environment.....	1-5
1.3.2	Storage environment.....	1-7
[1]	Temporary storage.....	1-7
[2]	Long-term storage.....	1-7
Chapter 2	INSTALLATION AND WIRING	
2.1	Installation.....	2-1
2.2	Wiring.....	2-3
2.2.1	Basic connection diagram.....	2-3
2.2.2	Removal and attachment of the front cover/ terminal cover and wiring guide.....	2-6
2.2.3	Precautions for wiring.....	2-8
2.2.4	Precautions for long wiring (between inverter and motor).....	2-9
2.2.5	Main circuit terminals.....	2-11
[1]	Screw specifications.....	2-11
[2]	Terminal layout diagram (main circuit terminal).....	2-14
[3]	Recommended wire size (main circuit terminals).....	2-16
[4]	Description of terminal functions (main circuit terminal).....	2-37
2.2.6	Control circuit terminals (common to all models).....	2-41
[1]	Screw specifications and recommended wire size (control circuit terminals).....	2-41
[2]	Terminal layout diagram (control circuit terminal).....	2-41
[3]	Description of terminal functions (control circuit terminal).....	2-42
2.2.7	Switching connector (types VXT-203 or above).....	2-50
2.2.8	Operating slide switches.....	2-52
2.3	Attachment and Connection of Keypad.....	2-53
2.3.1	Parts required for connection.....	2-53
2.3.2	Attachment procedure.....	2-54
2.4	RJ-45 Cover.....	2-57
Chapter 3	OPERATION USING THE KEYPAD	
3.1	Names and Functions of Keypad Components.....	3-1
3.2	Overview of Operation Modes.....	3-3
Chapter 4	TEST RUN PROCEDURE	
4.1	Test Run Procedure Flowchart.....	4-1
4.2	Checking Prior to Powering On.....	4-2
4.3	Powering ON and Checking.....	4-3
4.4	Destination setting.....	4-4
4.5	Switching the Applicable Motor Rating (ND, HD, HND and HHD Modes).....	4-6
Chapter 5	FUNCTION CODES	
5.1	Function Codes Overview.....	5-1
5.2	Function Codes Table.....	5-1
5.2.1	Supplementary note.....	5-1
5.2.2	Function codes table.....	5-3
5.2.3	Factory default value per applicable electric motor capacitance.....	5-35
Chapter 6	TROUBLESHOOTING	
6.1	Protective Function.....	6-1

6.2	Before Proceeding with Troubleshooting	6-2
6.3	If an Alarm Code Appears on the LED Monitor	6-3
6.3.1	Alarm code list	6-3
Chapter 7 MAINTENANCE AND INSPECTION		
7.1	Inspection Interval	7-1
7.2	Daily Inspection	7-2
7.3	Periodic Inspection	7-3
7.3.1	Periodic inspection 1--Before the inverter is powered ON or after it stops running	7-3
7.3.2	Periodic inspection 2--When the inverter is ON or it is running	7-4
7.4	List of Periodic Replacement Parts	7-4
7.4.1	Judgment on service life	7-5
[1]	Measuring the capacitance of DC link bus capacitor in comparison with initial one at shipment	7-6
[2]	Measuring the capacitance of the DC link bus capacitor under ordinary operating conditions	7-7
[3]	Early warning of lifetime alarm	7-7
7.5	Measurement of Electrical Amounts in Main Circuit	7-8
7.6	Insulation Test	7-9
7.7	Inquiries about Product and Guarantee	7-9
7.7.1	When making an inquiry	7-9
7.7.2	Product warranty	7-10
[1]	Free of charge warranty period and warranty range	7-10
[2]	Exclusion of liability for loss of opportunity, etc.	7-11
[3]	Repair period after production stop, spare parts supply period (holding period)	7-11
[4]	Transfer rights	7-11
[5]	Service contents	7-11
[6]	Applicable scope of service	7-11
Chapter 8 SPECIFICATIONS		
8.1	Standard Model	8-2
8.1.1	ND-mode inverters for general load	8-2
8.1.2	HD-mode inverters for heavy duty load	8-5
8.1.3	HND-mode inverters for general load	8-8
8.1.4	HHD-mode inverters for heavy duty load	8-13
8.2	EMC Filter Built-in Type	8-19
8.2.1	ND-mode inverters for general load	8-19
8.2.2	HD-mode inverters for heavy duty load	8-19
8.2.3	HND-mode inverters for general load	8-20
8.2.4	HHD-mode inverters for heavy duty load	8-22
8.3	Common Specifications	8-23
Chapter 9 EXTERNAL DIMENSIONS		
9.1	Standard Model (VXT-69A-2, VXT-44A-4, VXT11A-1 or below)	9-1
9.2	Standard / EMC Filter Built-in Type (VXT-88A-2 / 2E, VXT-59A-4 / 4E or above)	9-6
9.3	Keypad	9-14

■ Safety precautions

Read this manual thoroughly before proceeding with installation, connections (wiring), operation, or maintenance and inspection. Ensure you have sound knowledge of the device and familiarize yourself with all safety information and precautions before proceeding to operate the inverter.

Safety precautions are classified into the following two categories in this manual.

 WARNING	Failure to heed the information indicated by this symbol may lead to dangerous conditions, possibly resulting in death or serious bodily injuries.
 CAUTION	Failure to heed the information indicated by this symbol may lead to dangerous conditions, possibly resulting in minor or light bodily injuries and/or substantial property damage.

Failure to heed the information contained under the CAUTION title can also result in serious consequences. These safety precautions are of utmost importance and must be observed at all times.

Application

 WARNING
<ul style="list-style-type: none"> The Jaguar VXT is designed to drive a three-phase induction motor. Do not use it for single-phase motors or for other purposes. Fire or an accident could occur. The Jaguar VXT may not be used for a life-support system or other purposes directly related to the human safety. Though the Jaguar VXT is manufactured under strict quality control, install safety devices for applications where serious accidents or property damages are foreseen in relation to the failure of it. An accident could occur.

Installation

 WARNING
<ul style="list-style-type: none"> Install the inverter on a base made of metal or other non-flammable material. Otherwise, a fire could occur. Do not place flammable object nearby. Doing so could cause fire. Inverters VXT-85 or above, whose protective structure is IP00, involve a possibility that a human body may touch the live conductors of the main circuit terminal block. Inverters to which an optional DC reactor is connected also involve the same. Install such inverters in an inaccessible place. Otherwise, electric shock or injuries could occur.

 CAUTION
<ul style="list-style-type: none"> Do not support the inverter by its front cover during transportation. Doing so could cause a drop of the inverter and injuries. Prevent lint, paper fibres, sawdust, dust, metallic chips, or other foreign materials from getting into the inverter or from accumulating on the heat sink. When changing the positions of the top and bottom mounting bases for external cooling, use only the specified screws. Otherwise, a fire or an accident might result. Do not install or operate an inverter that is damaged or lacking parts. Doing so could cause fire, an accident or injuries.

Wiring

WARNING

- If no zero-phase current (earth leakage current) detective device such as a ground-fault relay is installed in the upstream power supply line, in order to avoid the entire power supply system's shutdown undesirable to factory operation, install a residual-current-operated protective device (RCD)/earth leakage circuit breaker (ELCB) individually to inverters to break the individual inverter power supply lines only.

Otherwise, a fire could occur.

- When wiring the inverter to the power source, insert a recommended moulded case circuit breaker (MCCB) or residual-current-operated protective device (RCD)/earth leakage circuit breaker (ELCB) (with overcurrent protection) in the path of each pair of power lines to inverters. Use the recommended devices within the recommended current capacity.
- Use wires in the specified size.
- Tighten terminals with specified torque.

Otherwise, a fire could occur.

- When there is more than one combination of an inverter and motor, do not use a multicore cable for the purpose of handling their wirings together.
- Do not connect a surge arrester to the inverter's output (secondary) circuit.

Doing so could cause a fire.

- Be sure to connect an optional DC reactor (DCR) when the capacity of the power supply transformer exceeds 500 kVA and is 10 times or more the inverter rated capacity.

Otherwise, a fire could occur.

- Ground the inverter in compliance with the national or local electric code.
- Be sure to ground the inverter's grounding terminals .

Otherwise, an electric shock or a fire could occur.

- Qualified electricians should perform all wiring.
- Be sure to perform wiring after turning the power OFF.

Otherwise, an electric shock could occur.

- Be sure to perform wiring after installing the inverter unit.

Otherwise, an electric shock or injuries could occur.

- Ensure that the number of input phases and the rated voltage of the product match the number of phases and the voltage of the AC power supply to which the product is to be connected.

Otherwise, a fire or an accident could occur.

- Do not connect the power supply wires to output terminals (U, V, and W).
- When connecting a DC braking resistor (DBR), never connect it to terminals other than terminals P(+) and DB.

Doing so could cause fire or an accident.

- In general, sheaths of the control signal wires are not specifically designed to withstand a high voltage (i.e., reinforced insulation is not applied). Therefore, if a control signal wire comes into direct contact with a live conductor of the main circuit, the insulation of the sheath might break down, which would expose the signal wire to a high voltage of the main circuit. Make sure that the control signal wires will not come into contact with live conductors of the main circuit.

Doing so could cause an accident or an electric shock.

WARNING

- Before changing the switches or touching the control circuit terminal symbol plate, **turn OFF the power and wait at least five minutes for inverters VXT-115A-2E / VXT-72-4E / VXT-11A-7E or below, or at least ten minutes for inverters VXT-85A-4E or above.** Make sure that the LED monitor and charging lamp are turned OFF. Further, make sure, using a multi-meter or a similar instrument, that the DC link bus voltage between the terminals P(+) and N(-) has dropped to the safe level (+25 VDC or below).

Otherwise, an electric shock could occur.

CAUTION

- The inverter, motor and wiring generate electric noise. Be careful about malfunction of the nearby sensors and devices. To prevent them from malfunctioning, implement noise control measures.

Otherwise an accident could occur.

Operation

WARNING

- Be sure to mount the front cover before turning the power ON. Do not remove the cover when the inverter power is ON.

Otherwise, an electric shock could occur.

- Do not operate switches with wet hands.



Doing so could cause electric shock.

- If the auto-reset function has been selected, the inverter may automatically restart and drive the motor depending on the cause of tripping. Design the machinery or equipment so that human safety is ensured at the time of restarting.

Otherwise, an accident could occur.

- If the stall prevention function (current limiter), automatic deceleration (anti-regenerative control), or overload prevention control has been selected, the inverter may operate with acceleration/deceleration or frequency different from the commanded ones. Design the machine so that safety is ensured even in such cases.

- The  key on the keypad is effective only when the keypad operation is enabled with function code F02 (= 0, 2 or 3). When the keypad operation is disabled, prepare an emergency stop switch separately for safe operations.

Switching the run command source from keypad (local) to external equipment (remote) by turning ON the "Enable communications link" command **LE** disables the  key. To enable the  key for an emergency stop, select the STOP key priority with function code H96 (= 1 or 3).

- If any of the protective functions have been activated, first remove the cause. Then, after checking that the all run commands are set to OFF, release the alarm. If the alarm is released while any run commands are set to ON, the inverter may supply the power to the motor, running the motor.

Otherwise, an accident could occur.

- If you enable the "Restart mode after momentary power failure" (Function code F14 = 3 to 5), then the inverter automatically restarts running the motor when the power is recovered.

Design the machinery or equipment so that human safety is ensured after restarting.

- If the user configures the function codes wrongly without completely understanding the User's Manual, the motor may rotate with a torque or at a speed not permitted for the machine.

- Starting auto-tuning involves motor rotation. Sufficiently check that motor rotation brings no danger beforehand.

An accident or injuries could occur.

- Even if the inverter has interrupted power to the motor, if the voltage is applied to the main circuit input terminals L1/R, L2/S, L3/T, L1/L and L2/N, voltage may be output to inverter output terminals U, V, and W.

- Even if the motor is stopped due to DC braking or preliminary excitation, voltage is output to inverter output terminals U, V, and W.

An electric shock may occur.

- The inverter can easily accept high-speed operation. When changing the speed setting, carefully check the specifications of motors or equipment beforehand.

Otherwise, injuries could occur.

CAUTION

- Do not touch the heat sink and braking resistor because they become very hot.

Doing so could cause burns.

- The DC brake function of the inverter does not provide any holding mechanism.

Injuries could occur.

- Ensure safety before modifying the function code settings. Run commands (e.g., "Run forward" **FWD**), stop commands (e.g., "Coast to a stop" **BX**), and frequency change commands can be assigned to digital input terminals. Depending upon the assignment states of those terminals, modifying the function code setting may cause a sudden motor start or an abrupt change in speed.
- When the inverter is controlled with the digital input signals, switching run or frequency command sources with the related terminal commands (e.g., **SS1**, **SS2**, **SS4**, **SS8**, **Hz2/Hz1**, **Hz/PID**, **IVS**, and **LE**) may cause a sudden motor start or an abrupt change in speed.
- Ensure safety before modifying customizable logic related function code settings (U codes and related function codes) or turning ON the "Cancel customizable logic" terminal command **CLC**. Depending upon the settings, such modification or cancellation of the customizable logic may change the operation sequence to cause a sudden motor start or an unexpected motor operation.

An accident or injuries could occur.

Maintenance and inspection, and parts replacement

WARNING

- Before proceeding to the maintenance/inspection jobs, **turn OFF the power and wait at least five minutes for inverters VXT-115A-2E / VXT-72A-4E / VXT-11A-1E or below, or at least ten minutes for inverters VXT-85A-4E or above.** Make sure that the LED monitor and charging lamp are turned OFF. Further, make sure, using a multi-meter or a similar instrument, that the DC link bus voltage between the terminals P(+) and N(-) has dropped to the safe level (+25 VDC or below).

Otherwise, an electric shock could occur.

- Always carry out the daily and periodic inspections described in the instruction/user's manual. Use of the inverter for long periods of time without carrying out regular inspections could result in malfunction or damage, and an accident or fire could occur.
- It is recommended that periodic inspections be carryout every one to two years, however, they should be carried out more frequently depending on the usage conditions.
- It is recommended that parts for periodic replacement be replaced in accordance with the standard replacement frequency indicated in the user's manual. Use of the product for long periods of time without replacement could result in malfunction or damage, and an accident or fire could occur.
- Contact outputs [30A/B/C] use relays, and may remain ON, OFF, or undetermined when their lifetime is reached. In the interests of safety, equip the inverter with an external protective function.

Otherwise, an accident or fire could occur.

- Maintenance, inspection, and parts replacement should be made only by qualified persons.
- Take off the watch, rings and other metallic objects before starting work.
- Use insulated tools.

Otherwise, an electric shock or injuries could occur.

- Never modify the inverter.

Doing so could cause an electric shock or injuries.

Disposal

CAUTION

- Treat the inverter as an industrial waste when disposing of it.

Otherwise injuries could occur.

IMO Jaguar inverter 5 year warranty

. Terms of IMO 5 year warranty.

- IMO Jaguar Inverters are covered by a 5 year warranty from date of despatch.
- In the event of failure due to faulty components or inferior workmanship, the Inverter will be replaced or repaired free Warranty replacements and repaired units will be despatched free of charge, all costs related to faulty units being returned to IMO for inspection/repair are the responsibility of the sender.
- In circumstances where it is viable for the Inverter to be repaired in situ due to size (>30kw), an Engineer from IMO or contracted to represent IMO can be supplied. Site visits are chargeable at IMO's current service rate, any warranty parts will be replaced free of charge.
- All Inverters require a Returns Authorisation reference to be supplied with the Inverter upon returning the drive to IMO, this reference can be obtained from our website www.imopconline.com by registering and following the returns instructions.

Warranty restrictions.

- Incorrect, or unsafe installation.
- Poor condition due to abuse, neglect or improper maintenance.
- Modifications, repairs performed by anyone other than IMO or without prior written agreement.
- Inverter used in incorrect application or used for function other than for which it is designed.
- Any alterations, which may invalidate the Inverters CE declaration.
- Non IMO options or ancillary devices used.

Liability.

- Regardless whether a breakdown occurs during or after the warranty period, IMO shall not be liable for any loss of opportunity, loss of profits, penalty clauses or damages arising from any special circumstances, secondary damages, accident compensation to another company, damages to any equipment, or personal injury.

GENERAL PRECAUTIONS

Drawings in this manual may be illustrated without covers or safety shields for explanation of detail parts. Restore the covers and shields in the original state and observe the description in the manual before starting operation.

Icons

The following icons are used throughout this manual.



This icon indicates information which, if not heeded, can result in the inverter not operating to full efficiency, as well as information concerning incorrect operations and settings which can result in accidents.



This icon indicates information that can be useful when performing certain settings or operations.



This icon indicates a reference to more detailed information.

Chapter 1 BEFORE USE

1.1 Acceptance Inspection (Nameplates and Inverter Type)

Unpack the package and check the following:

- (1) An inverter and the following accessories are contained in the package.
 Accessories - DC reactor (for ND-mode inverters of VXT-139A-4 or above, HD/HND-mode inverters of VXT-168A-4 or above, and HHD-mode inverters of VXT-203A-4 or above)
 - Keypad rear cover (with three screws for securing the keypad)
 - Instruction manual
- (2) The inverter has not been damaged during transportation—there should be no dents or parts missing.
- (3) The inverter is the model you ordered. You can check the model and specifications on the main nameplate. (The main and sub nameplates are attached to the inverter as shown on Figure 1.2-1.)

IMO Precision Controls Ltd		UL LISTED			
TYPE	VXT-12A-4				
	ND	HD	HND	HHD	
SOURCE	3PH 380-480V 50/60Hz / 1PH 380-480V 50/60Hz				
	12A	8.5A	8.5A	9.0A	
OUTPUT	3PH 380-480V				
	0.1-120Hz	0.1-500Hz	0.1-500Hz	0.1-500Hz	
Source of 3PH	12A	11.1A	11.1A	9.0A	
Source of 1PH	-	-	-	5.6A	
SD1 IP Code IP20		SCCR 100kA	MASS	kg	
SER.No. T31A123A0579AA		HEIGHT	mm	www.imopc.com	

(a) Main Nameplate

TYPE	VXT12A-4
SER.No	T31A123A0579AA

(b) Sub Nameplate

Figure 1.1-1 Nameplates

The Jaguar VXT is available in four different drive modes--ND (Normal Duty), HD (Heavy Duty), HND (High, Normal Duty), and HHD (High, Heavy Duty). One of these modes should be selected to match the load property of your system. Specifications in each mode are printed on the main nameplate.

- ND mode : Designed for general load applications.
Overload capability: 120% for 1 min.
- HD mode : Designed for heavy duty load applications.
Overload capability: 150% for 1 min.
- HND mode : Designed for general load applications.
Overload capability: 120% for 1 min.
- HHD mode : Designed for heavy duty load applications.
Overload capability: 150% for 1 min. and 200% for 0.5 s.
- SOURCE : Number of input phases (three-phase: 3PH), input voltage, input frequency, input current
- OUTPUT : Number of output phases, rated output voltage, output frequency range, rated output capacity, rated output current, and overload capability
- SCCR : Short-circuit capacity
- MASS : Mass of the inverter in kilogram
- SER. No. : Product number

1.1 Acceptance Inspection (Nameplates and Inverter Type)

400V / 3 Phase Models

VXT - 2A - 4 E

Drive		Filter	
series prefix	VXT	no filter	
		E	integrated EMC filter

Max. Continuous Output Current (A)		Input Voltage (V) / Phase			
2Amp output current	2A	4	400V / 3 Phase		
4Amp output current	4A				
6Amp output current	6A				
7Amp output current	7A				
12Amp output current	12A			139A	139Amp output current
22Amp output current	22A			168A	168Amp output current
29Amp output current	29A			203A	203Amp output current
37Amp output current	37A			240A	240Amp output current
44Amp output current	44A			290A	290Amp output current
59Amp output current	59A			361A	361Amp output current
72Amp output current	72A			415A	415Amp output current
85Amp output current	85A			520A	520Amp output current
105Amp output current	105A			590A	590Amp output current

200V / 3 Phase Models

VXT - 4A - 2 E

Drive		Filter	
series prefix	VXT	no filter	
		E	integrated EMC filter

Max. Continuous Output Current (A)		Input Voltage (V) / Phase			
4Amp output current	4A	2	200V / 3 Phase		
6Amp output current	6A				
10Amp output current	10A				
12Amp output current	12A				
20Amp output current	20A			69A	69Amp output current
30Amp output current	30A			88A	88Amp output current
40Amp output current	40A			115A	115Amp output current

200V / 1 Phase Models

VXT - 8A - 1 E

Drive		Filter	
series prefix	VXT	no filter	
		E	integrated EMC filter

Max. Continuous Output Current (A)		Input Voltage (V) / Phase	
3Amp output current	3A	1	200V / 1 Phase
5Amp output current	5A		
8Amp output current	8A		
11Amp output current	11A		



: Compliance with European Standards (See Appendix G Section G-1)



: Compliance with UL Standards and Canadian Standards (cUL certification)
(See Appendix G Section G-2)



: Compliance with the Radio Waves Act (South Korea) (See Appendix G Section G-3)



: Compliance with Russian Standards

If you suspect the product is not working properly or if you have any questions about your product, contact IMO.

1.2 External View and Terminal Blocks

(1) Outside and inside views

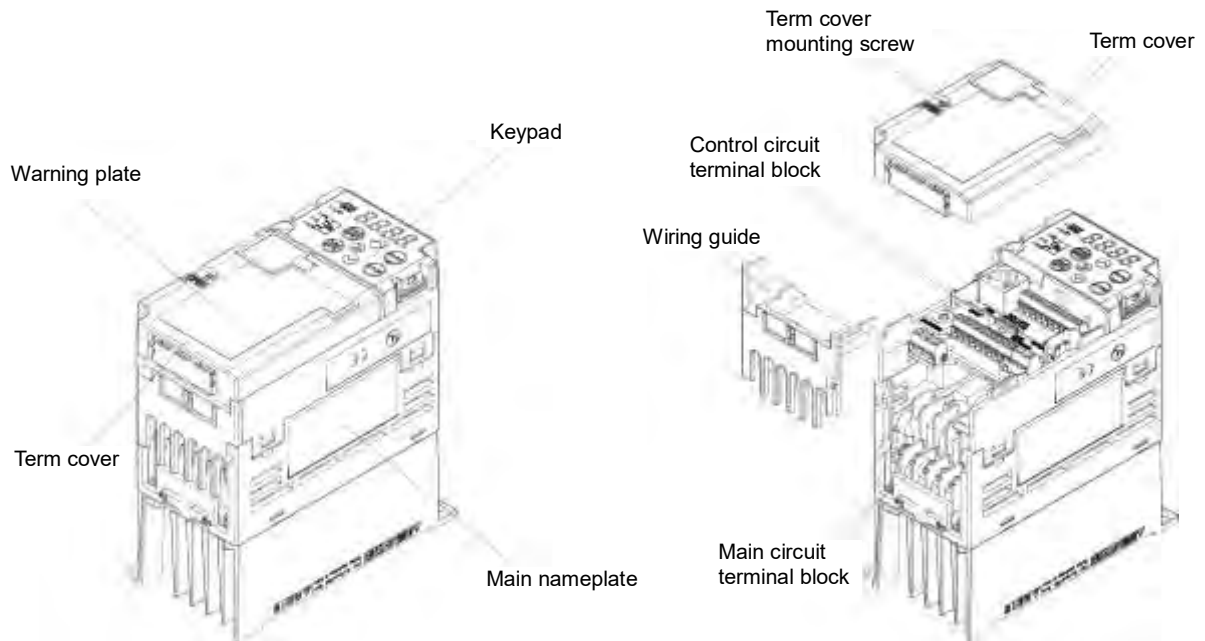

(a) VXT-6A-2#

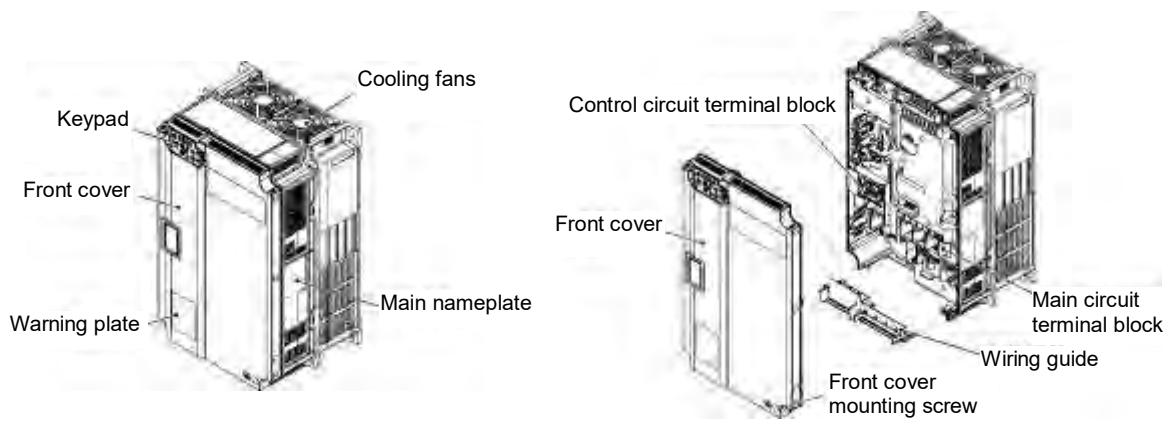

(b) VXT-72A-4

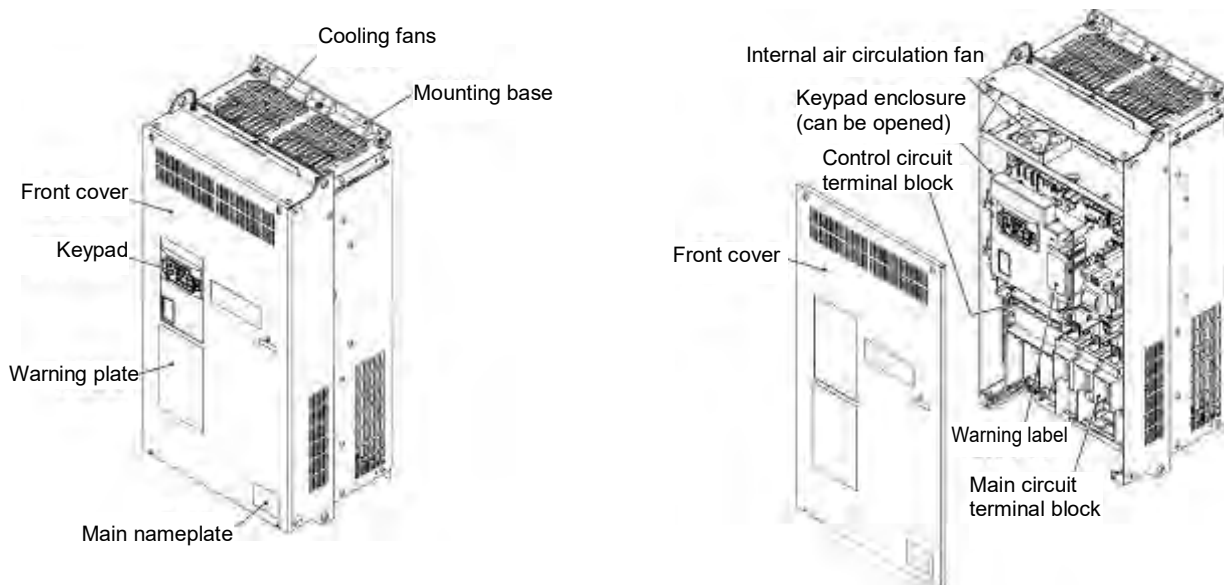

(c) VXT-590A-4

Figure 1.2-1 Outside and Inside Views of Inverters

(2) Warning plates and label

⚠ WARNING ⚠

- RISK OF INJURY OR ELECTRIC SHOCK
- Refer to the instruction manual before installation and operation.
- Do not remove any cover while applying power and at least 5min. after disconnecting power.
- Securely ground (earth) the equipment.
- High touch current.

⚠ AVERTISSEMENT

■ RISQUE DE BLESSURE OU DE CHOC ÉLECTRIQUE
Ne retirez pas le couvercle lorsque vous mettez sous tension.

- Ce couvercle peut être retiré au moins 5 minutes après la mise hors tension et quand le témoin « ACTIF » s'éteint.
- Plus d'un circuit électrique actif. Reportez-vous au manuel d'instruction.

⚠ 警告 ■ けが、感電のおそれあり

- 取付け、運転の前に必ず取扱説明書を読んでその指示に従ってください。
- 運転中および電源切り断後5分以上は装置カバーを開けないこと。
- 確実に接地をおこなってください。

Only type B of RCD is allowed.
See manual for details.

(a) VXT-6A-4

⚠ WARNING ⚠

■ RISK OF INJURY OR ELECTRIC SHOCK

- Refer to the instruction manual before installation and operation.
- Do not remove the cover while applying power.
- This cover can be removed after at least 10 min of power off and after the "CHARGE" lamp turns off.
- More than one line circuit. See instruction manual.
- Do not insert fingers or anything else into the inlets.
- Securely ground (earth) the equipment.
- High touch current.

⚠ 警告

■ けがや感電引起る恐れあり

- 取付け、運転の前に必ず取扱説明書を読んでその指示に従ってください。
- 運転中および電源切り断後10分以上は装置カバーを開けないこと。
- 確実に接地をおこなってください。
- 複数の電線が接続される場合があります。取扱説明書をご覧ください。
- 指や物を入れないでください。
- 必ず確実に接地をおこなってください。
- 高感電電流に注意してください。

Only type B of RCD is allowed.
See manual for details.

(b) VXT-203A-4

⚠ AVERTISSEMENT

■ RISQUE DE BLESSURE OU DE CHOC ÉLECTRIQUE

- Ne retirez pas le couvercle lorsque vous mettez sous tension.
- Ne pas ouvrir cette couvercle pendant 10 minutes après avoir coupé l'alimentation ou lors de la mise sous tension.
- Plus d'un circuit électrique actif. Reportez-vous au manuel d'instruction.

Figure 1.2-2 Warning Plates and Label

1.3 Precautions for Using Inverters

This section provides precautions in introducing inverters, e.g. precautions for installation environment, power supply lines, wiring, and connection to peripheral equipment. Be sure to observe those precautions.

1.3.1 Usage environment

Install the inverter in an environment that satisfies the requirements listed in Table 1.3-1.

Table 1.3-1 Usage Environment

Item	Specifications	
Site location	Indoors	
Ambient temperature	Standard (Open Type) -10 to +50°C (14 to 122°F) (HHD/HND spec.) (Note 1) -10 to +40°C (14 to 104°F) (HD/ND spec.) NEMA/UL Type1 -10 to +40°C (14 to 104°F) (HHD/HND spec.) -10 to +30°C (14 to 86°F) (HD/ND spec.)	
Relative humidity	5 to 95% RH (No condensation)	
Atmosphere	The inverter must not be exposed to dust, direct sunlight, corrosive gases, flammable gases, oil mist, vapor or water drops. Pollution degree 2 (IEC60664-1) (Note 2) The atmosphere can contain a small amount of salt (0.01 mg/cm ² or less per year). The inverter must not be subjected to sudden changes in temperature that will cause condensation to form.	
Altitude	1,000 m (3,300 ft) max. (Note 3)	
Atmospheric pressure	86 to 106 kPa	
Vibration	VXT-115A-2 or below VXT-203A-4 or below VXT-11A-1 or below	VXT-240A-4# or above
	3 mm (Max. amplitude) 2 to less than 9 Hz	3 mm (Max. amplitude) 2 to less than 9 Hz
	9.8 m/s ² 9 to less than 20 Hz	2 m/s ² 9 to less than 55 Hz
	2 m/s ² 20 to less than 55 Hz	1 m/s ² 55 to less than 200 Hz
	1 m/s ² 55 to less than 200 Hz	

(Note 1) When inverters are mounted side-by-side without any clearance between them (VXT-11-1 / VXT-115A-2 / VXT-72-4 or below), the ambient temperature should be within the range from -10 to +40°C.

(Note 2) Do not install the inverter in an environment where it may be exposed to lint, cotton waste or moist dust or dirt which will clog the heat sink of the inverter. If the inverter is to be used in such an environment, install it in a dustproof panel of your system.

(Note 3) If you use the inverter in an altitude above 1,000 m (3,300 ft), you should apply an output current de-rating factor as listed in Table 1.3-2.

Table 1.3-2 Output Current De-rating Factor in Relation to Altitude

Altitude	Output current de-rating factor
1,000 m or lower (3,300 ft or lower)	1.00
1,000 to 1500 m (3,300 to 4,900 ft)	0.97
1,500 to 2,000 m (4,900 to 6,600 ft)	0.95
2,000 to 2,500 m (6,600 to 8,200 ft)	0.91
2,500 to 3,000 m (8,200 to 9,800 ft)	0.88

1.3 Precautions for Using Inverters

IMO strongly recommends installing inverters in a panel for safety reasons, in particular, when installing the ones whose enclosure rating is IP00.

When installing the inverter in a place out of the specified environmental requirements, it is necessary to de-rate the inverter or consider the panel engineering design suitable for the special environment or the panel installation location. The special environments listed below require using the specially designed panel or considering the panel installation location.

Environments	Possible problems	Sample measures	Applications
Highly concentrated sulfurizing gas or other corrosive gases	Corrosive gases cause parts inside the inverter to corrode, resulting in an inverter malfunction.	Any of the following measures may be necessary. <ul style="list-style-type: none"> - Mount the inverter in a sealed panel with IP6X or air-purge mechanism. - Place the panel in a room free from influence of the gases. 	Paper manufacturing, sewage disposal, sludge treatment, tire manufacturing, gypsum manufacturing, metal processing, and a particular process in textile factories.
A lot of conductive dust or foreign material (e.g., metal powders or shavings, carbon fibers, or carbon dust)	Entry of conductive dust into the inverter causes a short circuit.	Any of the following measures may be necessary. <ul style="list-style-type: none"> - Mount the inverter in a sealed panel. - Place the panel in a room free from influence of the conductive dust. 	Wiredrawing machines, metal processing, extruding machines, printing presses, combustors, and industrial waste treatment.
A lot of fibrous or paper dust	Fibrous or paper dust accumulated on the heat sink lowers the cooling effect. Entry of dust into the inverter causes the electronic circuitry to malfunction.	Any of the following measures may be necessary. <ul style="list-style-type: none"> - Mount the inverter in a sealed panel that shuts out dust. - Ensure a maintenance space for periodical cleaning of the heat sink in panel engineering design. - Employ external cooling when mounting the inverter in a panel for easy maintenance and perform periodical maintenance. 	Textile manufacturing and paper manufacturing.
High humidity or dew condensation	In an environment where a humidifier is used or where the air conditioner is not equipped with a dehumidifier, high humidity or dew condensation results, which causes a short-circuiting or malfunction of electronic circuitry inside the inverter.	<ul style="list-style-type: none"> - Put a heating module such as a space heater in the panel. 	Outdoor installation. Film manufacturing line, pumps and food processing.
Vibration or shock exceeding the specified level	If a large vibration or shock exceeding the specified level is applied to the inverter, for example, due to a carrier running on seam joints of rails or blasting at a construction site, the inverter structure gets damaged.	<ul style="list-style-type: none"> - Insert shock-absorbing materials between the mounting base of the inverter and the panel for safe mounting. 	Installation of an inverter panel on a carrier or self-propelled machine. Ventilating fan at a construction site or a press machine.
Fumigation for export packaging	Halogen compounds such as methyl bromide used in fumigation corrodes some parts inside the inverter.	<ul style="list-style-type: none"> - When exporting an inverter built in a panel or equipment, pack them in a previously fumigated wooden crate. - When packing an inverter alone for export, use a laminated veneer lumber (LVL). 	Exporting.

1.3.2 Storage environment

The storage environment in which the inverter should be stored after purchase differs from the usage environment. Store the inverter in an environment that satisfies the requirements listed below.

[1] Temporary storage

Table 1.3-3 Storage and Transport Environments

Item	Specifications	
Storage temperature *1	During transport: -25 to +70°C (-13 to +158°F)	Places not subjected to abrupt temperature changes or condensation or freezing
	During storage: -25 to +65°C (-13 to +153°F)	
Relative humidity	5 to 95% RH *2	
Atmosphere	The inverter must not be exposed to dust, direct sunlight, corrosive or flammable gases, oil mist, vapor, water drops or vibration. The atmosphere must contain only a low level of salt. (0.01 mg/cm ² or less per year)	
Atmospheric pressure	86 to 106 kPa (during storage)	
	70 to 106 kPa (during transportation)	

*1 Assuming comparatively short time storage, e.g., during transportation or the like.

*2 Even if the humidity is within the specified requirements, avoid such places where the inverter will be subjected to sudden changes in temperature that will cause condensation or freezing.

Precautions for temporary storage

- (1) Do not leave the inverter directly on the floor.
- (2) If the environment does not satisfy the specified requirements listed in Table 1.3-3, wrap the inverter in an airtight vinyl sheet or the like for storage.
- (3) If the inverter is to be stored in a high-humidity environment, put a drying agent (such as silica gel) in the airtight package described in (2) above.

[2] Long-term storage

The long-term storage method of the inverter varies largely according to the environment of the storage site. General storage methods are described below.

- (1) The storage site must satisfy the requirements specified for temporary storage.
However, for storage exceeding three months, the surrounding temperature range should be within the range from -10 to +30°C (14 to 86°F). This is to prevent electrolytic capacitors in the inverter from deterioration.
- (2) The package must be airtight to protect the inverter from moisture. Add a drying agent inside the package to maintain the relative humidity inside the package within 70%.
- (3) If the inverter has been installed to the equipment or panel at construction sites where it may be subjected to humidity, dust or dirt, then temporarily remove the inverter and store it in the environment specified in Table 1.3-3.

Precautions for storage over 1 year

If the inverter has not been powered on for a long time, the property of the electrolytic capacitors may deteriorate. Power the inverters on once a year and keep the inverters powering on for 30 to 60 minutes. Do not connect the inverters to the load circuit (secondary side) or run the inverter.

Chapter 2 INSTALLATION AND WIRING

2.1 Installation

(1) Installation Environment

Please install Jaguar VXT in locations which meet the conditions specified in Chapter 1 “1.3.1 Usage environment”.

(2) Installation Surface

Please install the inverter on non-combustible matter such as metals. Also, do not mount it upside down or horizontally.

⚠ WARNING
Install on non-combustible matter such as metals.
Risk of fire exists

(3) Surrounding Space

Secure the space shown in Figure 2.1-1 and Table 2.1-1. When enclosing Jaguar VXT in cabinets, be sure to provide adequate ventilation to the cabinet, as the surrounding temperature may rise. Do not contain it in small enclosures with low heat dissipation capacity.

■ Installation of Multiple Inverters

When installing 2 or more units in the same equipment or cabinet, generally mount them to the side of each other, not above each other. When the inverters are mounted above each other, attach partitioning boards to prevent that the heat dissipated from the lower inverter affects the upper inverter.

For types VXT-72A-4, VXT-115A-2, VXT-11A-1 or below and for ambient temperature below 40°C only, the units can be installed side by side without any spacing between them. (30°C or lower for ND and HD)

Table 2.1-1 Surrounding Space mm (inch)

Applicable Capacity	A	B	C
200 V class: VXT-4A to 115A-2	10	100 (3.9)	0 *1
200 V class: VXT-3A to 11A-1 400 V class: VXT-2A to 72A-4	(0.39)		
400 V class: VXT-85 to 590A-4	50 (1.97)	100 (3.9)	

*1 A clearance of 50 mm is required to use RJ45 connector.

C: Space in front of the inverter unit

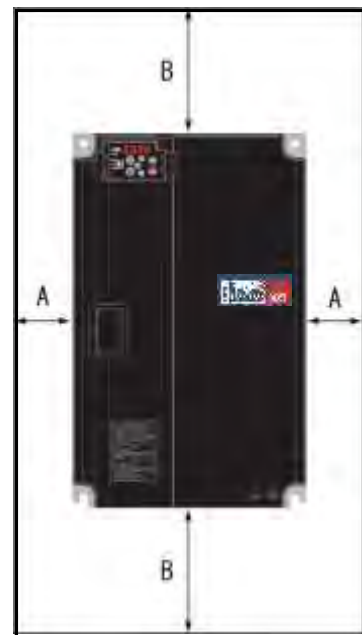

Figure 2.1-1 Installation Direction

■ Installation with External Cooling

The external cooling installation reduces the generated heat inside the panel by dissipating approximately 70% of the total heat generated (total heat loss) by mounting the cooling fins protruding outside the equipment or cabinet.

Installation with external cooling is possible for types VXT-30 to 115A-2 and VXT-22 to 72A-4 by adding attachments (optional) for external cooling, and for types VXT-85A-4 or above by moving the mounting bases.

(Please refer to the Jaguar VXT- User's Manual, Chapter 11 Item 11.15 for the external dimensions drawing of the external cooling attachment (optional)).

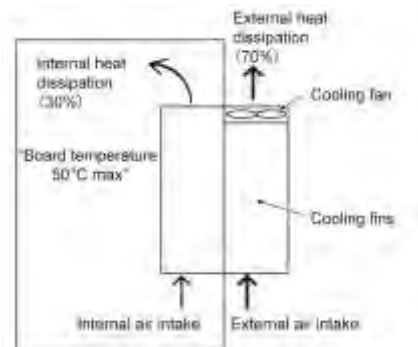

Figure 2.1-2 Installation with External Cooling

⚠ CAUTION
Prevent lint, wastepaper, wood shavings, dust, metal scrap, and other foreign material from entering the inverter or from attaching to the cooling fins.
Risk of fire and risk of accidents exist

To install the VXT-85A-4 inverter with external cooling, change the mounting position of the mounting bases

following the procedure in Figure 2.1-3.

As the type and number of screws differ by inverter type, please review Table 2.1-2.

Table 2.1-2 Type and Number of Screws, and Tightening Torque

Inverter type	Mounting base fixation screw	Case attachment screw	Tightening torque N·m (lb-in)
VXT-85A-4 to VXT-168A-4	M6×20 (5 screws on top, 3 screws on bottom)	M6×20 (2 screws on top only)	5.8 (51.3)
VXT-203A-4	M6×20 (3 screws on top and bottom each)	M6×12 (3 screws on top only)	5.8 (51.3)
VXT-240A-4 to VXT-290A-4	M5×12 (7 screws on top and bottom each)	M5×12 (7 screws on top only)	3.5 (31.0)
VXT-361A-4 to VXT-415A-4	M5×16 (7 screws on top and bottom each)	M5×16 (7 screws on top only)	3.5 (31.0)
VXT-520A-4 to VXT-590A-4	M5×16 (8 screws on top and bottom each)	M5×16 (8 screws on top only)	3.5 (31.0)

- 1) Remove all of the mounting base fixation screws and the case attachment screws on the top of the inverter.
- 2) Fix the mounting bases to the case attachment screw holes using the mounting base fixation screws. A few screws should remain after changing the position of the mounting bases.
- 3) Change the position of the mounting bases on the bottom side following the procedure in 1) and 2).

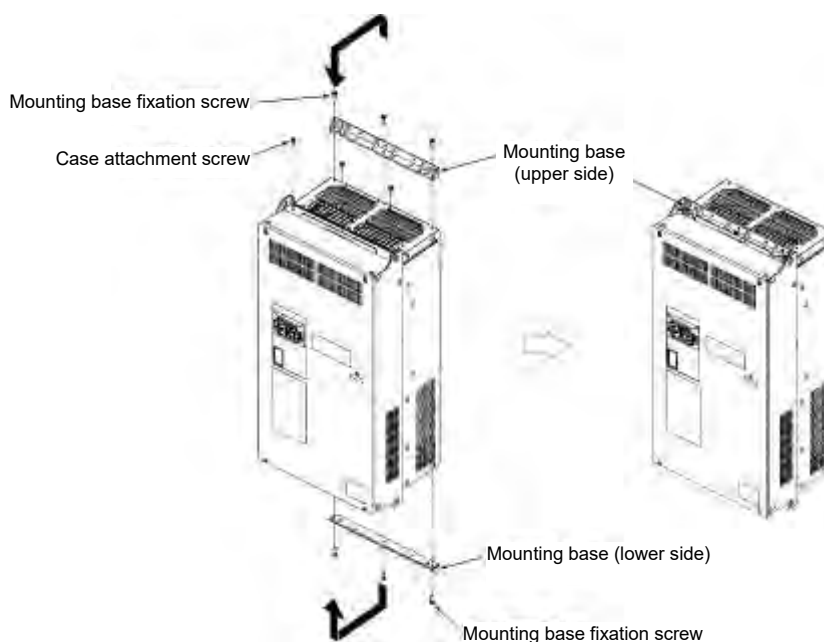

Figure 2.1-3 Method to Change the Mounting Base Positions

⚠ CAUTION
Use the specified screws in changing the mounting bases.
Risk of fire and risk of accidents exist

■ Inverter unit installation screw size

Select the bolt size, considering the thickness of the mounting feet and installation surface so that the bolt protrudes from the nut by 2 threads or more.

Inverter type	Inverter fixation screw	Tightening torque N·m (lb-in)
200V class : VXT-30/40A-2 400V class : VXT-22/29A-4	M5 (4 screws)	3.5 (31.0)
200V class : VXT-56/69A-2 400V class : VXT-37A-4 to VXT-203A-4	M8 (4 screws)	13.5 (119)
400V class : VXT-240A-4 to VXT-415A-4	M12 (4 screws)	48 (425)
400V class : VXT-520A-4 to VXT-590A-4	M12 (6 screws)	48 (425)

2.2 Wiring

2.2.1 Basic connection diagram

■ Standard model with CANopen (single analogue output) FM1

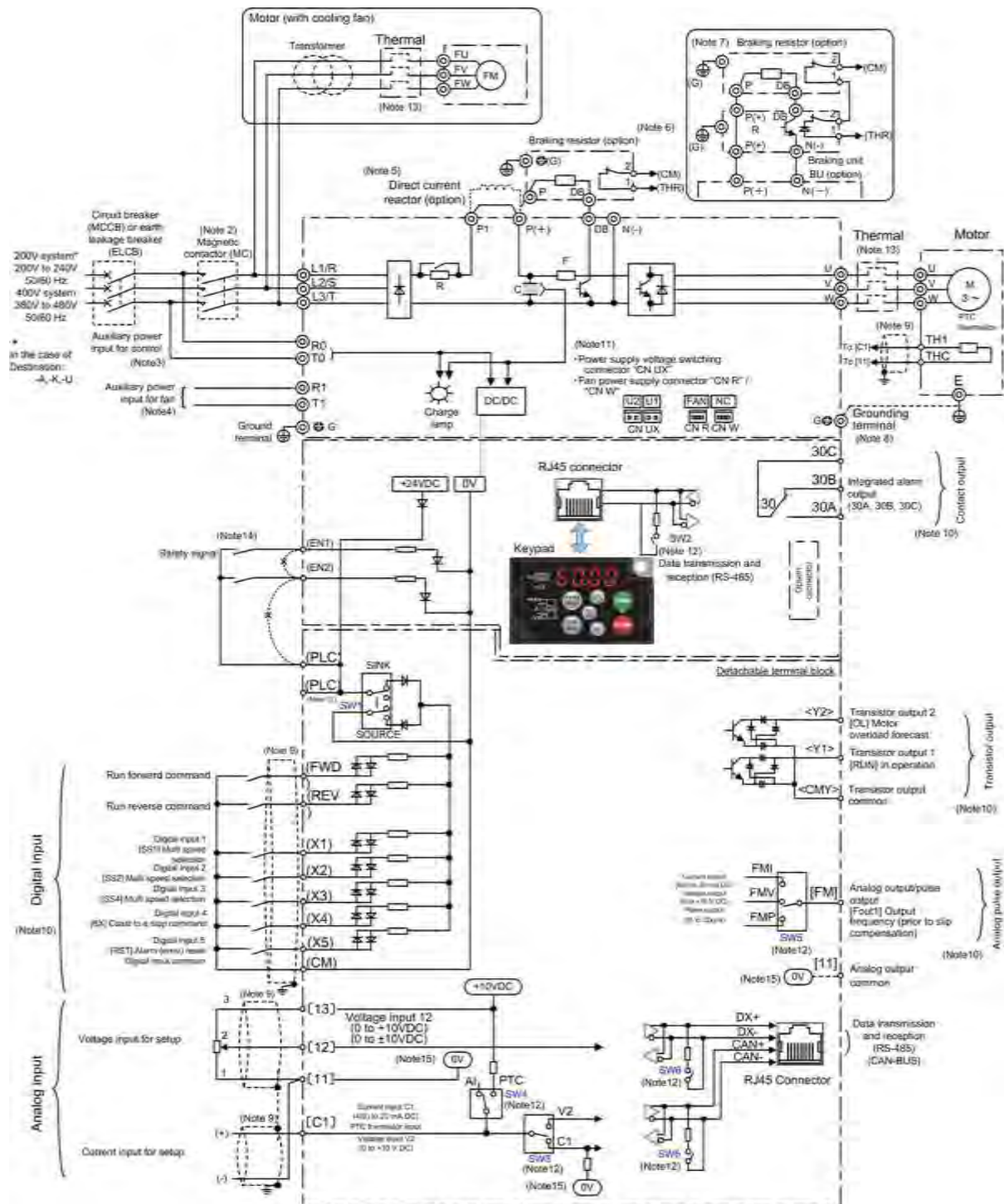

Figure 2.2-1 Standard model (with CAN)

■ Option model with 2 analogue outputs FM1 & FM2 (without CAN)

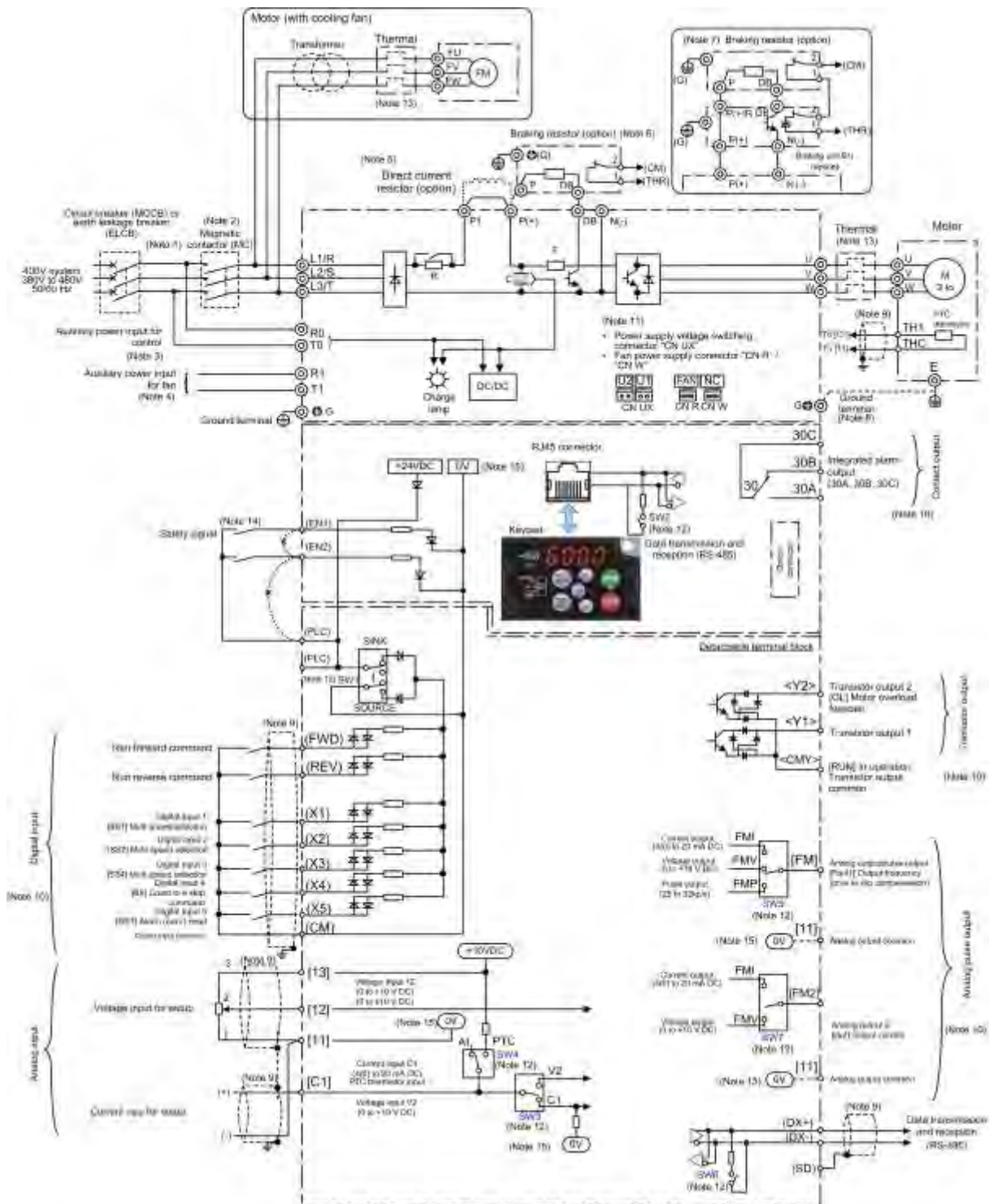

Figure 2.2-2 Option model (Without CAN)

- (Note 1) Install recommended circuit breakers (MCCB) or residual-current-operated protective device (RCD)/ earth leakage breakers (ELCB) (with overcurrent protective function) on the inputs of each inverter (primary side) for wiring protection. Do not use breakers which exceed the recommended rated current.
- (Note 2) Install recommended magnetic contactors (MC) as necessary on each inverter as these will be used to disconnect the inverter from the power supply separately from the MCCB or RCD / the ELCB. Additionally, when installing coils such as MC or solenoid close to the inverter, connect surge absorbers in parallel.
- (Note 3) When it is desired to retain the alarm signal for the activation of the protective function even inverter main power supply is shut off, or when it is desired continuous display of the keypad, connect this terminal to the power supply. The inverter can be operated without connecting power to this terminal (applicable for types VXT-59A-4 / VXT-88A-2 or above)
- (Note 4) The terminal does not need to be connected. Use this terminal when operating in combination with a high power factor regenerative PWM converter (RHC series). Applicable for types VXT-203A-4 or above)
- (Note 5) Remove the shorting bar between the inverter main circuit terminals P1-P(+) before connecting the direct current reactor (DCR) (option).
It must be connected in the following cases:
ND mode: Types VXT-139A-4 or above, HD/ HND mode: Types VXT-168A-4 or above, HHD mode: Types VXT-203A-4 or above.
Use the direct current reactor (option) when the power supply transformer capacity is above 500 kVA and the transformer capacity is over 10 times the rated capacity of the inverter, or when "thyristor load exists" in the same power system.
- (Note 6) Types VXT-11A-1 / VXT-115A-2 / VXT-72A-4 or below have built-in braking transistors, allowing direct connection of braking resistors between P(+)-DB.
- (Note 7) When connecting braking resistors to types VXT-85A-4 or above, always add the braking unit (option). Connect the braking unit (option) between P(+)-N(-). Auxiliary terminals [1] and [2] have polarity. Please connect as shown in the diagram.
- (Note 8) This terminal is used for grounding the motor. Grounding the motor using this terminal is recommended in order to suppress inverter noise.
- (Note 9) Use twisted lines or shielded lines for the control signals.
Generally, the shielded line requires grounding, but when the effect of externally induced noise is large, connecting to [CM] may suppress the effect of noise. Separate the line from the main circuit wiring and do not enclose in the same duct. (Separation distance of over 10 cm is recommended.) When crossing the main circuit wiring, make the intersection perpendicular.
- (Note 10) The various functions listed for terminals[X1] to [X5] (digital inputs), terminals [Y1] to [Y2] (transistor output), and terminal [FM] (monitor output) show the functions assigned as factory default.
- (Note 11) These are connectors for switching the main circuit. For details, refer to "2.2.7 Switching connector (types VXT-203A-4 or above)".
- (Note 12) The slide switches on the control printed circuit board define the settings for the inverter operation. For details, refer to "2.2.8 Operating slide switches".
- (Note 13) Make the circuit breakers (MCCB) or the magnetic contactors (MC) trip by the thermal relay auxiliary contacts (manual recovery).
- (Note 14) Shorting bars are connected between the safety function terminals [EN1], [EN2], and [PLC] as factory default. Remove the shorting bars when using this function.
- (Note 15) $\boxed{0V}$ and $\textcircled{0V}$ are separated and insulated.
- (Note 16) Charge lamp does not exist in the inverters VXT-69A-2 / VXT-44A-4 / VXT-11A-1 or below.

Route the wiring following the steps below. The descriptions assume that the inverter is already fixed to the cabinet.

2.2.2 Removal and attachment of the front cover/ terminal cover and wiring guide

⚠ CAUTION

Always remove the RS-485 communication cable from the RJ-45 connector before removing the front cover.

Risk of fire and risk of accidents exist.

(1) Types VXT-20A-2/ VXT-12A-4/ VXT-11A-1 or below

- 1) Loosen the screws of the terminal cover. To remove the terminal cover, put your finger in the dimple of the terminal cover and then pull it up toward you.
- 2) Pull out the wiring guide toward you.
- 3) After routing the wires, attach the wiring guide and the terminal cover reversing the steps above.

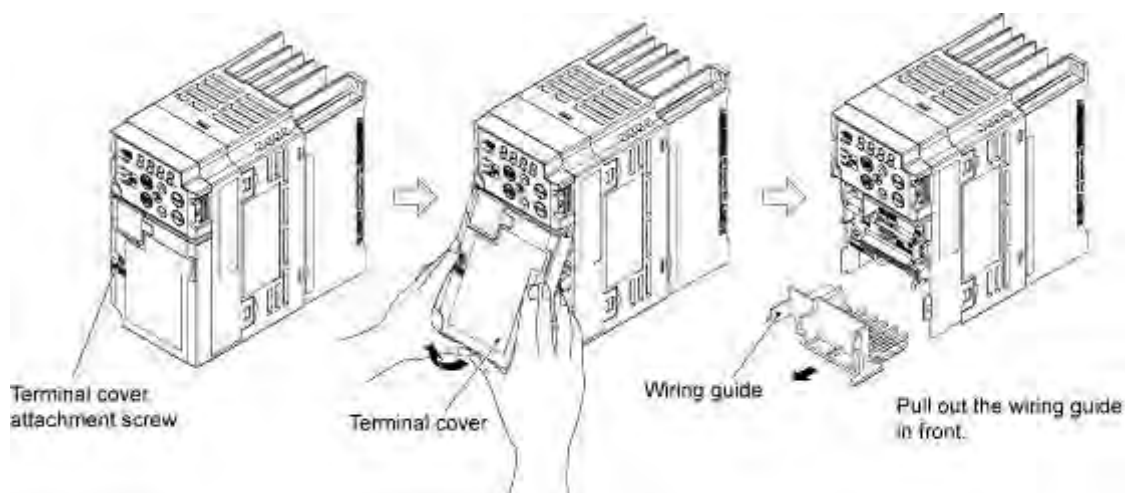

Figure 2.2-3 Removal of the Terminal Cover and the Wiring Guide (for VXT-6A-2)

(2) Types VXT-30A-2 to VXT-69A-2 and VXT-22A-4 to VXT-44A-4

- 1) Loosen the screws of the terminal cover. To remove the terminal cover, put your finger in the dimple of the terminal cover and then pull it up toward you.
- 2) Pull out the wiring guide toward you.
- 3) After routing the wires, attach the wiring guide and the terminal cover reversing the steps above.



Figure 2.2-4 Removal of the Terminal Cover and the Wiring Guide (for VXT-69A-2)

(3) Types VXT-88A-2 / VXT-115A-2 / VXT-72A-4 / VXT-85A-4

- 1) Loosen the screws of the front cover. Hold both sides of the front cover with the hands, slide the cover downward, and pull. Then remove it to the upward direction.
- 2) Push the wiring guide upward and pull. Let the wiring guide slide and remove it.
- 3) After routing the wires, attach the wiring guide and the front cover reversing the steps above.



Figure 2.2-5 Removal of the Front Cover and the Wiring Guide (for VXT-72A-4)

(4) Types VXT-85A-4 or above

- 1) Loosen the screws of the front cover. Hold both sides of the front cover with the hands and slide it upward to remove.
- 2) After routing the wires, align the front cover top edge to the screw holes and attach the cover reversing the steps in Figure 2.2-6.



Open the keypad case to view the control printed circuit board.

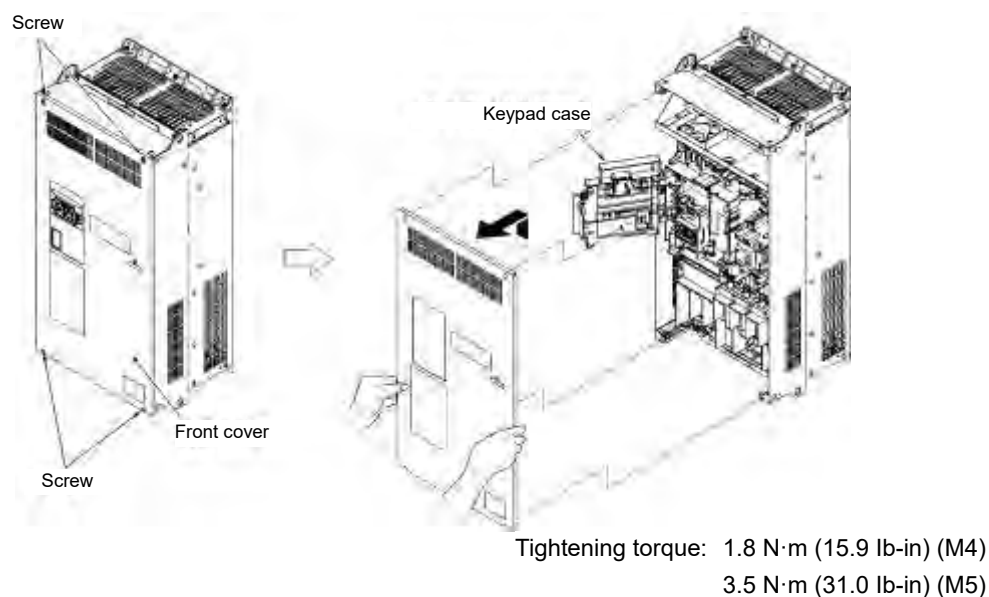
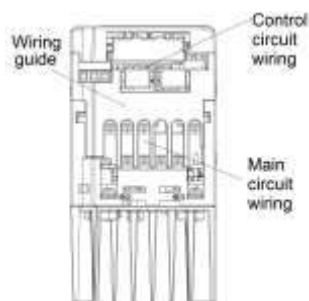

Figure 2.2-6 Removal of the front cover (for VXT-203A-4)

2.2.3 Precautions for wiring

Exercise caution for the following when wiring.

- (1) Confirm that the supply voltage is within the input voltage range described on the rating plate.
- (2) Always connect the power lines to the inverter main power input terminals L1/R, L2/S, L3/T (Three-phase). (The inverter will be damaged when power is applied if the power lines are connected to the wrong terminals.)
- (3) Always route the ground line to prevent accidents such as electric shock and fire and to reduce noise.
- (4) For the lines connecting to the main circuit terminals, use crimped terminals with insulating sleeves or use crimped terminals in conjunction with insulating sleeves for high connection reliability.
- (5) Separate the routing of the lines connected to the main circuit input side terminals (primary side) and the output side terminals (secondary side) and the lines connected to the control circuit terminals.
The control circuit terminal lines should be routed as far as possible from the main circuit routing. Malfunction may occur due to noise.
- (6) To prevent direct contact with the main circuit live sections (such as the main circuit terminal block), route the control circuit wiring inside the inverter as bundles using cable ties.
- (7) After removing a main circuit terminal screw, always restore the terminal screw in position and tighten even if lines are not connected.
- (8) The wiring guide is used to separately route the main circuit wiring and the control circuit wiring. The main circuit wiring and the control circuit wiring can be separated. Exercise caution for the order of wiring.



Case of VXT-6A-2

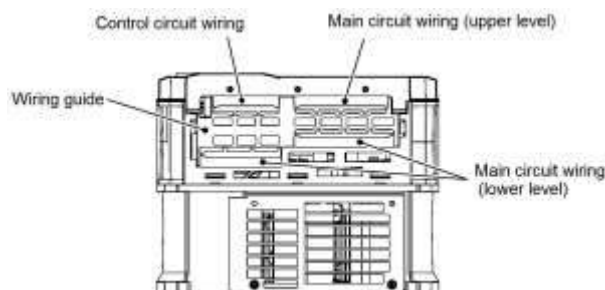

Case of VXT-72A-4

■ Handling the Wiring Guide

For inverter types VXT-4 to 115A-2 and VXT-2 to 72A-4, the wiring space may become insufficient when routing the main circuit wires, depending on the wire material used. In these cases, the relevant cut-off sections (see Figure 2.2-7, Figure 2.2-8) can be removed using a pair of nippers to secure routing space. Be warned that removing the wiring guide to accommodate the enlarged main circuit wiring will result in non-conformance to IP20 requirements.

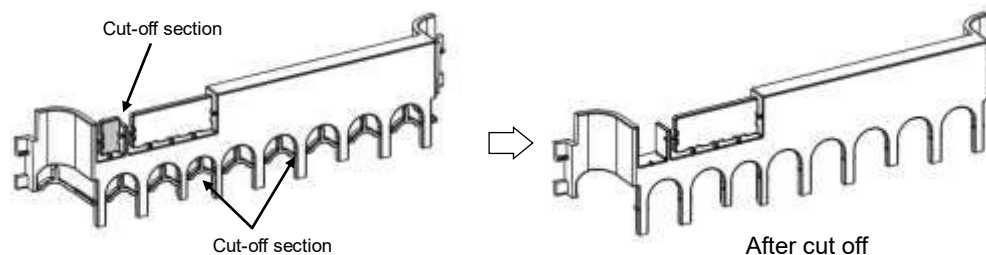

Figure 2.2-7 Wiring Guide (VXT-69A-2)

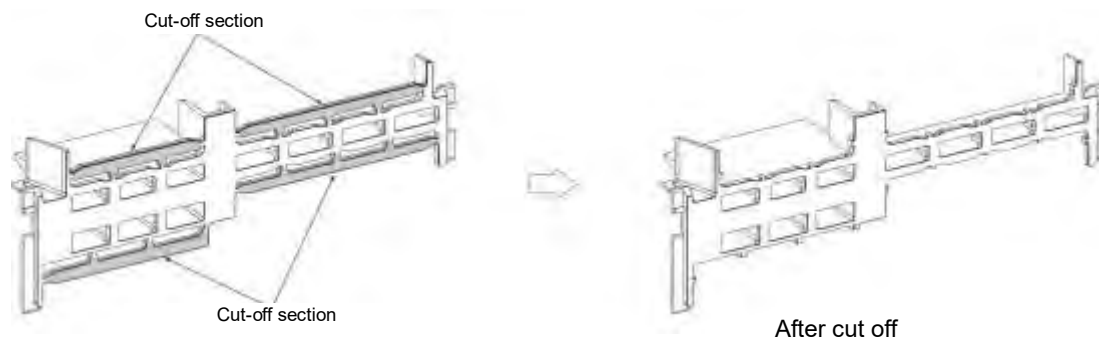
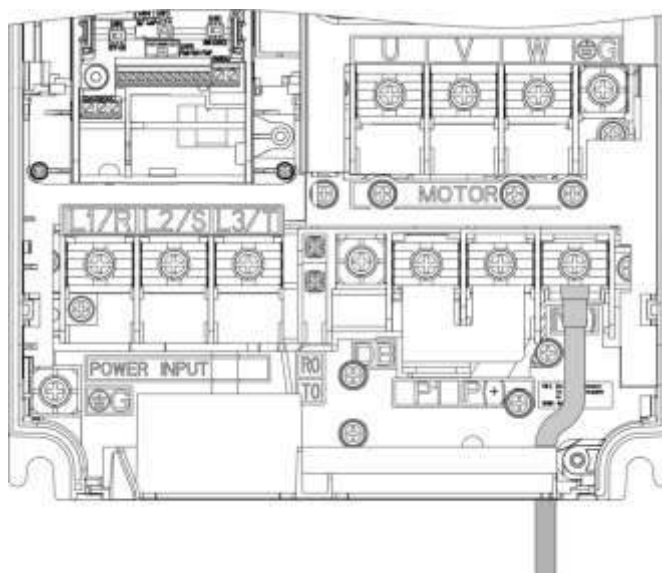

Figure 2.2-8 Wiring Guide (VXT-72A-4)

- (9) Depending on the inverter capacity, straight routing of the main circuit wires from the main circuit terminal block may not be possible. In these cases, route the wires as shown in the figure below and securely attach the front cover.



2.2.4 Precautions for long wiring (between inverter and motor)

- (1) When multiple motors are connected to one inverter, the wiring length is the total of all wire lengths.
- (2) Precautions shall be taken for high frequency leak current when the wiring length from the inverter to the motor is long, in this case the high frequency current may flow through the stray capacitance between the wires with various phases. The effect may cause the inverter to become overheated, or trip due to overcurrent. Leak current may increase and the accuracy of the displayed current may not be ensured. Depending on the conditions, excessive leak current may damage the inverter. To avoid the above problems when directly connecting an inverter to a motor, keep the wiring distance 50 m (164 ft) for inverters VXT-20A-2 / VXT-12A-4 / VXT-11A-1 or below, and below 100 m (328 ft) for inverters VXT-30A-2 / VXT-22A-4 or above.

To operate with longer wiring lengths than the ones above mentioned, reduce the carrier frequency or use an output circuit filter.

When multiple motors are operated in parallel connection configuration (group operation), and especially when shielded cables are used in the connections, the stray capacitance to ground is large. Reduce the carrier frequency or use output circuit filters.

Without output circuit filter	With output circuit filter

When the output circuit filter is used, the total wiring length should be below 400 m (1312ft) in case of using V/f control.

For motors with encoders, the wiring length between the inverter and motor should be below 100 m (328ft). The restriction comes from the encoder specifications. For distances beyond 100 m (328ft), insulation converters should be used. Please contact IMO when operating with wiring lengths beyond the upper limit.

- (3) Precautions on the surge voltage when driving the inverter (especially for 400 V series motor)
When motors are driven by inverters using the PWM method, the surge voltage generated by the switching of the inverter elements is added to the output voltage and is applied onto the motor terminals. Especially when the motor wiring length is long, the surge voltage can cause insulation degradation in the motor. Please perform one of the countermeasures shown below.
- Use motor with insulation enhancement.
 - Connect a surge suppression unit on the motor side.
 - Connect an output circuit filter to the inverter output side (secondary side).
 - Reduce the wiring length from the inverter to the motor to less than 10 to 20 meters (33 to 66ft).
- (4) When output circuit filters are attached to the inverter or when the wiring length is long, the voltage applied to the motor will decrease due to the voltage drop caused by the filter or wiring. In these cases, current oscillation and lack of torque may occur due to insufficient voltage.

⚠ WARNING ⚠

- For each inverter, connect to the power supply via circuit breaker and earth leakage breaker (with overcurrent protective function). Use recommended circuit breakers and earth leakage breakers and do not use breakers which exceed the recommended rated current.
- Always use the specified sizes for the wires.
- Tighten terminals with the defined tightening torque.
- When multiple combinations of inverters and motors exist, do not use multi-core cables for the purpose of bundling the various wires.
- Do not install surge killers on the inverter output side (secondary side)

Risk of fire exists.

- Ground the inverter in compliance with the national or local electric code.
- Always connect the ground line to the inverter grounding terminal [ZG]

Risk of electric shock and risk of fire exist.

- Qualified personnel should perform the wiring.
- Perform wiring after confirming that the power is shut off.

Risk of electric shock exists.

- Perform wiring only after the equipment is installed at the location.

Risk of electric shock and risk of injury exist.

- Confirm that the specifications (number of phases and the rated voltage) of the power supply input of the product match with the specifications of the power supply to be connected.
- Do not connect power supply lines to the inverter output terminals (U, V, W).

Risk of fire and risk of accidents exist.

2.2.5 Main circuit terminals

[1] Screw specifications

The specifications for the screws used in the main circuit wiring and the wire sizes are shown below. Exercise caution as the terminal position varies depending on inverter capacity. In the diagram in “[2] Terminal layout diagram (main circuit terminal)”, the two ground terminals [zG] are not differentiated for the input side (primary side) and the output side (secondary side).

Also, use crimped terminals with insulating sleeves compatible for main circuit or terminals with insulating tubes. The recommended wire sizes are shown depending on cabinet temperature and wire type.

Table 2.2-1 Screw Specifications (Three-phase 200V series, Basic type)

Power System	Inverter type	See item [2]	Screw specifications									
			Main circuit		Grounding		Auxiliary power input for control [R0, T0]		Auxiliary power input for fan [R1, T1]			
			Screw size (driver size)	Tightening torque N·m (lb-in)	Screw size (driver size)	Tightening torque N·m (lb-in)	Screw size	Tightening torque N·m (lb-in)	Screw size	Tightening torque N·m (lb-in)		
Three-phase 200 V	VXT-4A-2	Fig. a	M3.5	0.8 (7.1)	M3.5	1.2 (10.6)	—	—	—	—		
	VXT-6A-2											
	VXT-10A-2	Fig. b	M4	1.2 (10.6)	M4	1.8 (15.9)						
	VXT-12A-2											
	VXT-20A-2	Fig. c										
	VXT-30A-2	Fig. A	M5	3.0 (26.6)	M5	3.0 (26.6)						
	VXT-40A-2											
	VXT-56A-2	Fig. B	M6 (No.3)	5.8 (51.3)	M6 (No.3)	5.8 (51.3)						
	VXT-69A-2											
	VXT-88A-2	Fig. C	M6 (No.3)	5.8 (51.3)	M6 (No.3)	5.8 (51.3)					M3.5	1.2
	VXT-115A-2											

Table 2.2-2 Screw Specifications (Three-phase 200V series, EMC filter built-in type)

Power System	Inverter type	See item [2]	Screw specifications									
			Main circuit		Grounding		Auxiliary power input for control [R0, T0]		Auxiliary power input for fan [R1, T1]			
			Screw size (driver size)	Tightening torque N·m (lb-in)	Screw size (driver size)	Tightening torque N·m (lb-in)	Screw size	Tightening torque N·m (lb-in)	Screw size	Tightening torque N·m (lb-in)		
Three-phase 200 V	VXT-4A-2E	Fig. a	M3.5	0.8 (7.1)	M3.5	1.2 (10.6)	—	—	—	—		
	VXT-6A-2E											
	VXT-10A-2E	Fig. h	M4	1.2 (10.6)	M4	1.8 (15.9)						
	VXT-12A-2E											
	VXT-20A-2E	Fig. i	Input: M4 Other: M5	Input: 1.8(15.9) Other: 3.0(26.6)	M5	3.0 (26.6)						
	VXT-40A-2E											
	VXT-56A-2E	Fig. j	M6 (No.3)	Input: 8.1(71.7) Other: 5.8(51.3)	M6 (No.3)	5.8 (51.3)						
	VXT-69A-2E											
	VXT-88A-2E	Fig. C	M6 (No.3)	5.8 (51.3)	M6 (No.3)	5.8 (51.3)					M3.5	1.2
	VXT-115A-2E											

Table 2.2-3 Screw Specifications (Three-phase 400V series, Basic type)

Power System	Inverter type	See item [2]	Screw specifications											
			Main circuit		Grounding		Auxiliary power input for control [R0, T0]		Auxiliary power input for fan [R1, T1]					
			Screw size (driver size)	Tightening torque N·m (lb-in)	Screw size (driver size)	Tightening torque N·m (lb-in)	Screw size	Tightening torque N·m (lb-in)	Screw size	Tightening torque N·m (lb-in)				
Three-phase 400 V	VXT-2A-4	Fig. b	M4	1.2 (10.6)	M4	1.8 (15.9)	-	-	-	-				
	VXT-4A-4													
	VXT-6A-4													
	VXT-7A-4													
	VXT-12A-4	Fig. c	M5	3.0 (26.6)	M5	3.0 (26.6)								
	VXT-22A-4													
	VXT-29A-4													
	VXT-37A-4	Fig. B									M6 (No. 3)	5.8 (51.3)	M6 (No.3)	5.8 (51.3)
	VXT-44A-4													
	VXT-59A-4	Fig. C									M6 (No. 3)	5.8 (51.3)	M6 (No.3)	5.8 (51.3)
	VXT-72A-4													
	VXT-85A-4	Fig. D	M8	13.5 (119)	M8	13.5 (119)								
	VXT-105A-4													
	VXT-139A-4													
	VXT-168A-4													
	VXT-203A-4	Fig. E	M10	27 (239)	M3.5	1.2 (10.6)								
	VXT-240A-4	Fig. F												
	VXT-290A-4													
VXT-361A-4	Fig. G	M12	48 (425)	M10	27 (239)									
VXT-415A-4														
VXT-520A-4	Fig. H	M12	48 (425)	M10	27 (239)									
VXT-590A-4														

Table 2.2-4 Screw Specifications (Three-phase 400V series, EMC filter built-in type)

Power System	Inverter type	See item [2]	Screw specifications							
			Main circuit		Grounding		Auxiliary power input for control [R0, T0]		Auxiliary power input for fan [R1, T1]	
			Screw size (driver size)	Tightening torque N·m (lb-in)	Screw size (driver size)	Tightening torque N·m (lb-in)	Screw size	Tightening torque N·m (lb-in)	Screw size	Tightening torque N·m (lb-in)
Three-phase 400 V	VXT-2A-4E	Fig. g	M4	1.2 (10.6)	M4	1.8 (15.9)	-	-	-	-
	VXT-4A-4E									
	VXT-6A-4E	Fig. h	M4	1.2 (10.6)	M4	1.8 (15.9)				
	VXT-7A-4E									
	VXT-12A-4E									
	VXT-22A-4E	Fig. i	Input M4 Output M5	Input: 1.8(15.9) Other: 3.0(26.6)	M5	3.0 (26.6)				
	VXT-29A-4E									
	VXT-37A-4E	Fig. j	Input M4 Output M6	Input: 1.8(15.9) Other: 5.8(51.3)	M6 (No.3)	5.8 (51.3)				
	VXT-44A-4E									
	VXT-59A-4E	Fig. C	M6 (No. 3)	5.8 (51.3)	M6 (No.3)	5.8 (51.3)				
	VXT-72A-4E									
	VXT-85A-4E	Fig. D	M8	13.5 (119)	M8	13.5 (119)				
	VXT-105A-4E									
	VXT-139A-4E									
	VXT-168A-4E									
	VXT-203A-4E	Fig. E	M10	27 (239)	M3.5	1.2 (10.6)				
	VXT-240A-4E	Fig. F								
	VXT-290A-4E									
VXT-361A-4E	Fig. G	M12	48 (425)	M10	27 (239)					
VXT-415A-4E										
VXT-520A-4E	Fig. H	M12	48 (425)	M10	27 (239)					
VXT-590A-4E										

Table 2.2-5 Screw Specifications (Single-phase 200V series, Basic type)

Power System	Inverter type	See item [2]	Screw specifications							
			Main circuit		Grounding		Auxiliary power input for control [R0, T0]		Auxiliary power input for fan [R1, T1]	
			Screw size (driver size)	Tightening torque N·m (lb-in)	Screw size (driver size)	Tightening torque N·m (lb-in)	Screw size	Tightening torque N·m (lb-in)	Screw size	Tightening torque N·m (lb-in)
Single-phase 200 V	VXT-3A-1	Fig. k	M3.5	0.8 (7.1)	M3.5	1.2 (10.6)	-	-	-	-
	VXT-5A-1									
	VXT-8A-1	Fig. l	M4	1.2 (10.6)	M4	1.8 (15.9)				
	VXT-11A-1	Fig. m								

Table 2.2-6 Screw Specifications (Single-phase 200V series, EMC filter built-in type)

Power System	Inverter type	See item [2]	Screw specifications							
			Main circuit		Grounding		Auxiliary power input for control [R0, T0]		Auxiliary power input for fan [R1, T1]	
			Screw size (driver size)	Tightening torque N·m (lb-in)	Screw size (driver size)	Tightening torque N·m (lb-in)	Screw size	Tightening torque N·m (lb-in)	Screw size	Tightening torque N·m (lb-in)
Single-phase 200 V	VXT-3A-1E	Fig. k	M3.5	0.8 (7.1)	M3.5	1.2 (10.6)	-	-	-	-
	VXT-5A-1E	Fig. n								
	VXT-8A-1E	Fig. h	M4	1.2 (10.6)	M4	1.8 (15.9)				
	VXT-11A-1E									

[2] Terminal layout diagram (main circuit terminal)

Figure A

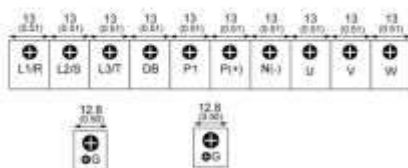

Figure B

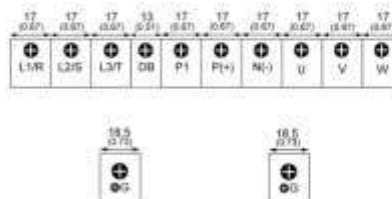

Figure C

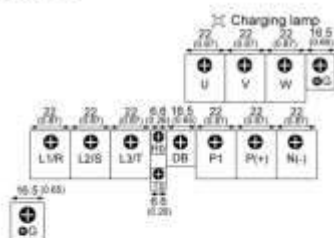

Figure D

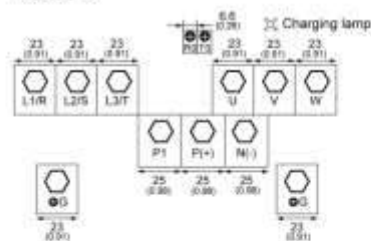

Figure E / Figure F

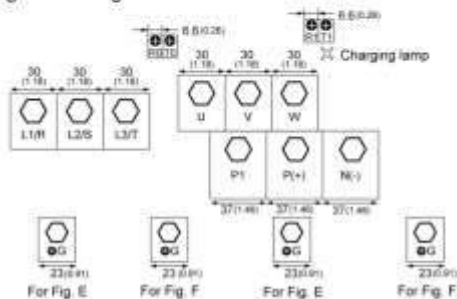
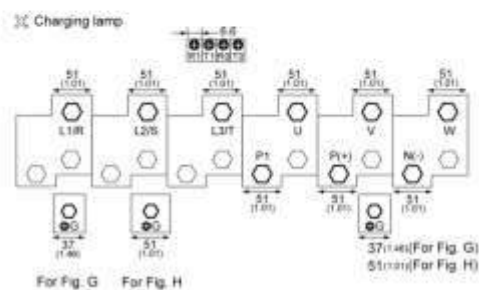

Figure G / Figure H



⚠ WARNING ⚠

The following terminals will have high voltage when power is ON.

Main circuit: L1/R, L2/S, L3/T, L1/L, L2/N, P1, P(+), N(-), DB, U, V, W, R0, T0, R1, T1

Insulation level

Main circuit - Casing : Basic insulation (overvoltage category III, degree of contamination 2)

Main circuit - Control circuit : Enhanced insulation (overvoltage category III, degree of contamination 2)

Risk of electric shock exists

Figure a

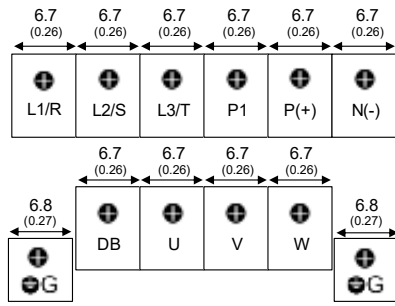

Figure b

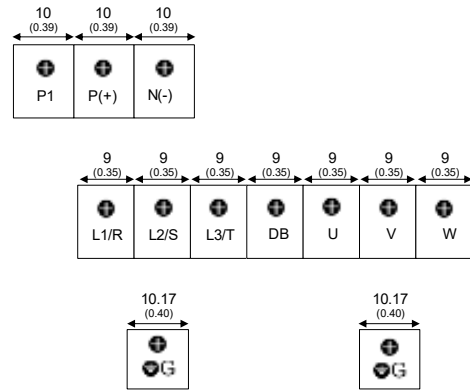

Figure c

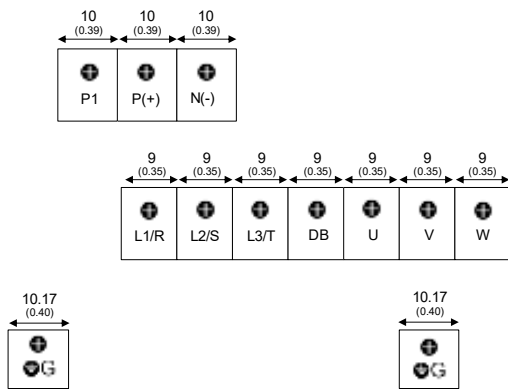

Figure i

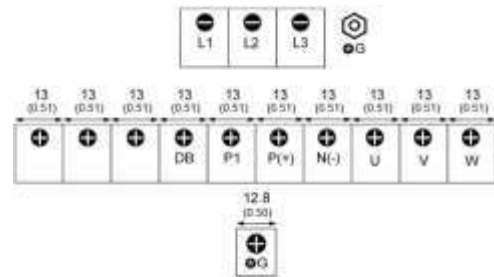

Figure j

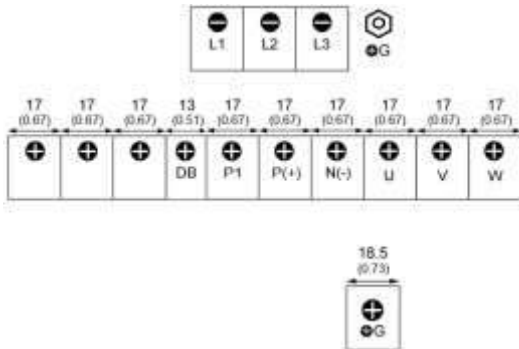

Figure k

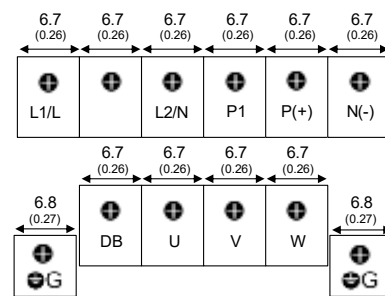

Figure l

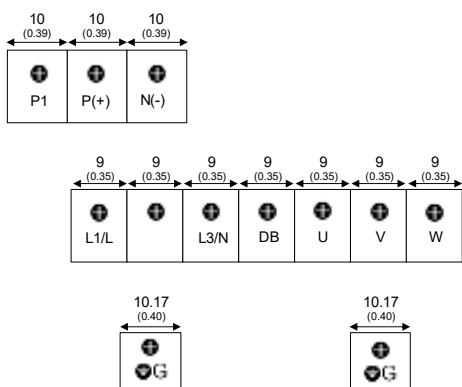
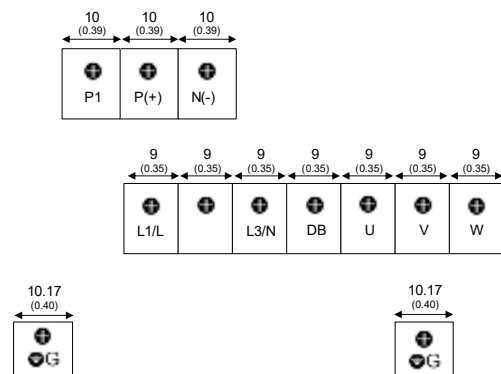

Figure m



For the figure g / h / n, please contact IMO.

[3] Recommended wire size (main circuit terminals)

The following wires are recommended unless special requirements exist.

■ **600 V vinyl insulation wire (IV wire)**

This wire is used in circuits except the inverter control circuit. The wire is difficult to twist and is not recommended for inverter control circuit. The maximum allowable temperature for the insulated wire is 60°C.

■ **600 V type 2 vinyl insulation wire or 600 V polyethylene insulation wire (HIV wire)**

In comparison to the IV wire, this wire is smaller, more flexible, and the maximum allowable temperature for the insulated wire is 75°C (higher), making it suitable for both the inverter main circuit and control circuit. However, the wiring distance should be short and the wire must be twisted for use in the inverter control circuit.

■ **600 V cross-linked polyethylene insulation wire (FSLC wire)**

This wire is used mainly in the main circuit and the grounding circuits. The size is even smaller than the IV wire or the HIV wire and also more flexible. Due to these features, the wire is used to reduce the area occupied by wiring and to improve work efficiency in high temperature areas. The maximum allowable temperature for the insulated wire is 90°C. As a reference, Furukawa Electric Co., Ltd. produces Boardlex which satisfies these requirements.

■ **Shielded-Twisted cables for internal wiring of electronic/electric instruments**

This product is used in inverter control circuits. Use this wire with high shielding effect when risk of exposure to or effect of radiated noise and induced noise exists. Always use this wire when the wiring distance is long, even within the cabinet. Furukawa Electric's BEAMEX S shielded cables XEBV or XEWV satisfy these requirements.

Table 2.2-7 Recommended Wire Sizes (Common Terminals)

Common terminals	Recommended wire size (mm ²) [AWG]	Remarks
Auxiliary power input terminals for control circuit R0, T0	2.0 [14]	VXT-88A-2 or above VXT-59A-4 or above
Auxiliary power input terminals for fan R1, T1	2.0 [14]	VXT-203A-4 or above

Refer to Appendix G-3 to conform the wire sizes to the UL Standards and Canadian Standards (cUL Certification).

(1) Wire sizes conforming to low voltage directive in Europe

Table 2.2-8 Recommended Wire Sizes, conforming to low voltage directive in Europe

ND Mode, Conforming to low voltage directive in Europe

Power System	Std Applicable Motor (kW)	Inverter type	Recommended wire size (mm ²)						
			Main power supply input [L1/R, L2/S, L3/T]		Ground terminal [zG]		Inverter output [U, V, W]	For DC reactor connection [P1, P(+)]	For braking resistor connection [P(+), DB]
			With DC reactor	Without DC reactor	With DC reactor	Without DC reactor			
Three-phase 400 V	0.75	VXT-2A-4#	2.5	2.5	2.5	2.5	2.5	2.5	2.5
	1.5	VXT-4A-4#	2.5	2.5	2.5	2.5	2.5	2.5	2.5
	2.2	VXT-6A-4#	2.5	2.5	2.5	2.5	2.5	2.5	2.5
	3.0	VXT-7A-4#	2.5	2.5	2.5	2.5	2.5	2.5	2.5
	5.5	VXT-12A-4#	2.5	2.5	2.5	2.5	2.5	2.5	2.5
	11	VXT-22A-4#	4	6	4	6	4	4	2.5
	15	VXT-29A-4#	6	10	6	10	6	6	2.5
	18.5	VXT-37A-4#	6	16	6	16	10	10	2.5
	22	VXT-44A-4#	10	16	10	16	10	16	2.5
	30	VXT-59A-4#	16	25	16	16	16	25	2.5
	37	VXT-72A-4#	25	35	16	16	25	25	2.5
	45	VXT-85A-4#	25	50	16	25	35	35	-
	55	VXT-105A-4#	35	70	16	35	50	50	-
	75	VXT-139A-4#	70	-	35	-	70	95	-
	90	VXT-168A-4#	95	-	50	-	95	120	-
	110	VXT-203A-4#	120	-	70	-	120	150	-
	132	VXT-240A-4#	150	-	95	-	150	95×2	-
	160	VXT-290A-4#	95×2	-	95	-	95×2	120×2	-
200	VXT-361A-4#	300	-	150	-	300	150×2	-	
220	VXT-415A-4#	300	-	150	-	150×2	185×2	-	
280	VXT-520A-4#	185×2	-	185	-	240×2	300×2	-	
315	VXT-590A-4#	240×2	-	240	-	240×2	300×2	-	

HD Mode, Conforming to low voltage directive in Europe

Power System	Std Applicable Motor (kW)	Inverter type	Recommended wire size (mm ²)						
			Main power supply input [L1/R, L2/S, L3/T]		Ground terminal [zG]		Inverter output [U, V, W]	For DC reactor connection [P1, P(+)]	For braking resistor connection [P(+), DB]
			With DC reactor	Without DC reactor	With DC reactor	Without DC reactor			
Three-phase 400 V	0.75	VXT-2A-4#	2.5	2.5	2.5	2.5	2.5	2.5	2.5
	1.1	VXT-4A-4#	2.5	2.5	2.5	2.5	2.5	2.5	2.5
	2.2	VXT-6A-4#	2.5	2.5	2.5	2.5	2.5	2.5	2.5
	3.0	VXT-7A-4#	2.5	2.5	2.5	2.5	2.5	2.5	2.5
	5.5	VXT-12A-4#	2.5	2.5	2.5	2.5	2.5	2.5	2.5
	7.5	VXT-22A-4#	2.5	4	2.5	4	2.5	2.5	2.5
	11	VXT-29A-4#	4	6	4	6	4	4	2.5
	15	VXT-37A-4#	6	10	6	10	6	6	2.5
	18.5	VXT-44A-4#	6	16	6	16	10	10	2.5
	22	VXT-59A-4#	10	16	10	16	10	16	2.5
	30	VXT-72A-4#	16	25	16	16	16	25	2.5
	37	VXT-85A-4#	25	35	16	16	25	25	-
	45	VXT-105A-4#	25	50	16	25	35	35	-
	55	VXT-139A-4#	35	70	16	35	50	50	-
	75	VXT-168A-4#	70	-	35	-	70	95	-
	90	VXT-203A-4#	95	-	50	-	95	120	-
	110	VXT-240A-4#	120	-	70	-	120	150	-
	132	VXT-290A-4#	150	-	95	-	150	95×2	-
160	VXT-361A-4#	185	-	95	-	240	300	-	
200	VXT-415A-4#	300	-	150	-	300	150×2	-	
220	VXT-520A-4#	300	-	150	-	150×2	185×2	-	
250	VXT-590A-4#	185×2	-	185	-	185×2	240×2	-	

The recommended wire sizes for the main circuit terminals assume using 70°C 600 V PVC wire at 40°C ambient temperature.

Table 2.2-9 Recommended Wire Sizes, conforming to low voltage directive in Europe (continued)

HND Mode, Conforming to low voltage directive in Europe

Power System	Std Applicable Motor (kW)	Inverter type	Recommended wire size (mm ²)						
			Main power supply input [L1/R, L2/S, L3/T]		Ground terminal [zG]		Inverter output [U, V, W]	For DC reactor connection [P1, P(+)]	For braking resistor connection [P(+), DB]
			With DC reactor	Without DC reactor	With DC reactor	Without DC reactor			
Three-phase 400 V	0.75	VXT-2A-4#	2.5	2.5	2.5	2.5	2.5	2.5	2.5
	1.1	VXT-4A-4#	2.5	2.5	2.5	2.5	2.5	2.5	2.5
	2.2	VXT-6A-4#	2.5	2.5	2.5	2.5	2.5	2.5	2.5
	3.0	VXT-7A-4# ^{*10}	2.5	2.5	2.5	2.5	2.5	2.5	2.5
	5.5	VXT-12A-4# ^{*10}	2.5	2.5	2.5	2.5	2.5	2.5	2.5
	7.5	VXT-22A-4#	2.5	4	2.5	4	2.5	2.5	2.5
	11	VXT-29A-4#	4	6	4	6	4	4	2.5
	15	VXT-37A-4#	6	10	6	16	6	6	2.5
	18.5	VXT-44A-4#	6	16	10	16	10	10	2.5
	22	VXT-59A-4#	10	16	10	16	10	16	2.5
	30	VXT-72A-4#	16	25	16	16	16	25	2.5
	37	VXT-85A-4#	25	35	16	16	25	25	-
	45	VXT-105A-4#	25	50	16	25	35	35	-
	55	VXT-139A-4#	35	70	16	35	50	50	-
	75	VXT-168A-4#	70	-	35	-	70	95	-
	90	VXT-203A-4#	95	-	50	-	95	120	-
	110	VXT-240A-4#	120	-	70	-	120	150	-
	132	VXT-290A-4#	150	-	95	-	150	95×2	-
160	VXT-361A-4#	185	-	95	-	240	300	-	
200	VXT-415A-4#	300	-	150	-	300	150×2	-	
220	VXT-520A-4#	300	-	150	-	150×2	185×2	-	
280	VXT-590A-4#	185×2	-	185	-	240×2	300×2	-	

HND Mode, Conforming to low voltage directive in Europe

Power System	Std Applicable Motor (kW)	Inverter type	Recommended wire size (mm ²)						
			Main power supply input [L1/R, L2/S, L3/T]		Ground terminal [zG]		Inverter output [U, V, W]	For DC reactor connection [P1, P(+)]	For braking resistor connection [P(+), DB]
			With DC reactor	Without DC reactor	With DC reactor	Without DC reactor			
Three-phase 400 V	0.4	VXT-2A-4#	2.5	2.5	2.5	2.5	2.5	2.5	2.5
	0.75	VXT-4A-4#	2.5	2.5	2.5	2.5	2.5	2.5	2.5
	1.5	VXT-6A-4#	2.5	2.5	2.5	2.5	2.5	2.5	2.5
	2.2	VXT-7A-4#	2.5	2.5	2.5	2.5	2.5	2.5	2.5
	3.7	VXT-12A-4#	2.5	2.5	2.5	2.5	2.5	2.5	2.5
	5.5	VXT-22A-4#	2.5	2.5	2.5	2.5	2.5	2.5	2.5
	7.5	VXT-29A-4#	2.5	4	2.5	4	2.5	2.5	2.5
	11	VXT-37A-4#	4	6	4	6	4	4	2.5
	15	VXT-44A-4#	6	10	6	10	6	6	2.5
	18.5	VXT-59A-4#	6	16	10	16	10	10	2.5
	22	VXT-72A-4#	10	16	10	16	10	16	2.5
	30	VXT-85A-4#	16	25	16	16	16	25	-
	37	VXT-105A-4#	25	35	16	16	25	25	-
	45	VXT-139A-4#	25	50	16	25	35	35	-
	55	VXT-168A-4#	35	70	16	35	50	50	-
	75	VXT-203A-4#	70	-	35	-	70	95	-
	90	VXT-240A-4#	95	-	50	-	95	120	-
	110	VXT-290A-4#	120	-	70	-	120	150	-
132	VXT-361A-4#	150	-	95	-	150	185	-	
160	VXT-415A-4#	185	-	95	-	240	300	-	
200	VXT-520A-4#	300	-	150	-	300	150×2	-	
220	VXT-590A-4#	300	-	150	-	150×2	185×2	-	
Single-phase 200 V	0.4	VXT-3A-1#	2.5	2.5	2.5	2.5	2.5	2.5	2.5
	0.75	VXT-5A-1#	2.5	2.5	2.5	2.5	2.5	2.5	2.5
	1.5	VXT-8A-1#	2.5	2.5	2.5	2.5	2.5	2.5	2.5
	2.2	VXT-11A-1#	2.5	4	2.5	4	2.5	2.5	2.5

The recommended wire sizes for the main circuit terminals assume using 70°C 600 V PVC wire at 40°C ambient temperature.

*10 ND-spec.

(2) Recommended Wire Sizes

1) Ambient temperature: Below 40°C, Wire type: 60°C wire

Table 2.2-10 Recommended wire size, Ambient temperature: Below 40°C, Wire type: 60°C wire

ND Mode, Ambient temperature: Below 40°C, Wire type: 60°C wire

Power System	Std Applicable Motor (kW)	Inverter type	Recommended wire size (mm ²)					
			Main power supply input [L1/R, L2/S, L3/T]		Ground terminal [zG]	Inverter output [U, V, W]	For DC reactor connection [P1, P(+)]	For braking resistor connection [P(+), DB]
			With DC reactor	Without DC reactor				
Three-phase 400 V	0.75	VXT-2A-4#	2	2	2	2	2	2
	1.5	VXT-4A-4#	2	2	2	2	2	2
	2.2	VXT-6A-4#	2	2	2	2	2	2
	3.0	VXT-7A-4#	2	2	2	2	2	2
	5.5	VXT-12A-4#	2	2	2	2	2	2
	11	VXT-22A-4#	2	5.5	3.5	2	3.5	2
	15	VXT-29A-4#	3.5	8	5.5	3.5	5.5	2
	18.5	VXT-37A-4#	5.5	14	5.5	5.5	8	2
	22	VXT-44A-4#	8	14	5.5	8	14	2
	30	VXT-59A-4#	14	22	8 ^{*1}	14	14	2
	37	VXT-72A-4#	14	38	8 ^{*1}	14	22	2
	45	VXT-85A-4#	22	38	8	22	38	-
	55	VXT-105A-4#	38	60	14	38	38	-
	75	VXT-139A-4#	60	-	14	60	60	-
	90	VXT-168A-4#	60	-	14	60	100 ^{*2}	-
	110	VXT-203A-4#	100	-	22	100	-	-
	132	VXT-240A-4#	100	-	22	100	-	-
	160	VXT-290A-4#	-	-	22	-	-	-
	200	VXT-361A-4#	-	-	38	-	-	-
220	VXT-415A-4#	-	-	38	-	-	-	
280	VXT-520A-4#	-	-	38	-	-	-	
315	VXT-590A-4#	-	-	60	-	-	-	

HD Mode, Ambient temperature: Below 40°C, Wire type: 60°C wire

Power System	Std Applicable Motor (kW)	Inverter type	Recommended wire size (mm ²)					
			Main power supply input [L1/R, L2/S, L3/T]		Ground terminal [zG]	Inverter output [U, V, W]	For DC reactor connection [P1, P(+)]	For braking resistor connection [P(+), DB]
			With DC reactor	Without DC reactor				
Three-phase 400 V	0.75	VXT-2A-4#	2	2	2	2	2	2
	1.1	VXT-4A-4#	2	2	2	2	2	2
	2.2	VXT-6A-4#	2	2	2	2	2	2
	3.0	VXT-7A-4#	2	2	2	2	2	2
	5.5	VXT-12A-4#	2	2	2	2	2	2
	7.5	VXT-22A-4#	2	3.5	2	2	2	2
	11	VXT-29A-4#	2	5.5	3.5	3.5	3.5	2
	15	VXT-37A-4#	3.5	8	5.5	5.5	5.5	2
	18.5	VXT-44A-4#	5.5	14	5.5	5.5	8	2
	22	VXT-59A-4#	8 ^{*1}	14	5.5	8 ^{*1}	14	2
	30	VXT-72A-4#	14	22	8 ^{*1}	14	14	2
	37	VXT-85A-4#	14	38	8	22	22	-
	45	VXT-105A-4#	22	38	8	22	38	-
	55	VXT-139A-4#	38	60	14	38	38	-
	75	VXT-168A-4#	60	-	14	60	60	-
	90	VXT-203A-4#	60	-	14	60	100	-
	110	VXT-240A-4#	100	-	22	100	-	-
	132	VXT-290A-4#	100	-	22	-	-	-
	160	VXT-361A-4#	-	-	22	-	-	-
200	VXT-415A-4#	-	-	38	-	-	-	
220	VXT-520A-4#	-	-	38	-	-	-	
250	VXT-590A-4#	-	-	38	-	-	-	

The recommended wire sizes for the main circuit terminals assume using 60°C IV wire.

*1 For compatible crimped terminals, please use model 8-L6 by JST Mfg. Co., Ltd. or equivalent.

*2 For compatible crimped terminals, please use model CB100-S8 by JST Mfg. Co., Ltd. or equivalent.

Table 2.2-11 Recommended wire sizes, Ambient temperature : Below 40°C, Wire type: 60°C wire

HND Mode, Ambient temperature: Below 40°C, Wire type: 60°C wire

Power System	Std Applicable Motor (kW)	Inverter type	Recommended wire size (mm ²)					
			Main power supply input [L1/R, L2/S, L3/T]		Ground terminal [zG]	Inverter output [U, V, W]	For DC reactor connection [P1, P(+)]	For braking resistor connection [P(+), DB]
			With DC reactor	Without DC reactor				
Three-phase 200 V	0.75	VXT-4A-2#	2	2	2	2	2	2
	1.1	VXT-6A-2#	2	2	2	2	2	2
	2.2	VXT-10A-2#	2	2	2	2	2	2
	3.0	VXT-12A-2# ^{*10}	2	2	2	2	2	2
	5.5	VXT-20A-2# ^{*10}	2	5.5	3.5	2	3.5	2
	7.5	VXT-30A-2#	3.5	8	5.5	3.5	5.5	2
	11	VXT-40A-2#	8	14	5.5	5.5	14	2
	15	VXT-56A-2#	14	22	5.5	14	14	2
	18.5	VXT-69A-2#	14	38	8	14	22	2
	22	VXT-88A-2#	22	38 ^{*7}	8	22	38 ^{*7}	2
30	VXT-115A-2#	38 ^{*7}	60 ^{*8}	14	38 ^{*7}	60 ^{*8}	2	
Three-phase 400 V	0.75	VXT-2A-4#	2	2	2	2	2	2
	1.1	VXT-4A-4#	2	2	2	2	2	2
	2.2	VXT-6A-4#	2	2	2	2	2	2
	3.0	VXT-7A-4# ^{*10}	2	2	2	2	2	2
	5.5	VXT-12A-4# ^{*10}	2	2	2	2	2	2
	7.5	VXT-22A-4#	2	3.5	2	2	2	2
	11	VXT-29A-4#	2	5.5	3.5	3.5	3.5	2
	15	VXT-37A-4#	3.5	8	3.5	5.5	5.5	2
	18.5	VXT-44A-4#	8	14	5.5	8	8	2
	22	VXT-59A-4#	8 ^{*1}	14	5.5	8 ^{*1}	14	2
	30	VXT-72A-4#	14	22	8 ^{*1}	14	14	2
	37	VXT-85A-4#	14	38	8	22	22	-
	45	VXT-105A-4#	22	38	8	22	38	-
	55	VXT-139A-4#	38	60	14	38	38	-
	75	VXT-168A-4#	60	-	14	60	60	-
	90	VXT-203A-4#	60	-	14	60	100	-
	110	VXT-240A-4#	100	-	22	100	-	-
	132	VXT-290A-4#	100	-	22	-	-	-
160	VXT-361A-4#	-	-	22	-	-	-	
200	VXT-415A-4#	-	-	38	-	-	-	
220	VXT-520A-4#	-	-	38	-	-	-	
280	VXT-590A-4#	-	-	38	-	-	-	

The recommended wire sizes for the main circuit terminals assume using 60°C IV wire.

- *1 For compatible crimped terminals, please use model 8-L6 by JST Mfg. Co., Ltd. or equivalent.
- *2 For compatible crimped terminals, please use model CB100-S8 by JST Mfg. Co., Ltd. or equivalent.
- *7 For compatible crimped terminals, please use model 38-6 by JST Mfg. Co., Ltd. or equivalent.
- *8 For compatible crimped terminals, please use model 60-6 by JST Mfg. Co., Ltd. or equivalent.
- *10 ND-spec.

Table 2.2-12 Recommended wire sizes, Ambient temperature : Below 40°C, Wire type: 60°C wire (continued)

HHD Mode, Ambient temperature: Below 40°C, Wire type: 60°C wire

Power System	Std Applicable Motor (kW)	Inverter type	Recommended wire size (mm ²)					
			Main power supply input [L1/R, L2/S, L3/T]		Ground terminal [zG]	Inverter output [U, V, W]	For DC reactor connection [P1, P(+)]	For braking resistor connection [P(+), DB]
			With DC reactor	Without DC reactor				
Three-phase 200 V	0.4	VXT-4A-2#	2	2	2	2	2	2
	0.75	VXT-6A-2#	2	2	2	2	2	2
	1.5	VXT-10A-2#	2	2	2	2	2	2
	2.2	VXT-12A-2#	2	2	2	2	2	2
	3.7	VXT-20A-2#	2	3.5	2	2	2	2
	5.5	VXT-30A-2#	2	5.5	3.5	3.5	3.5	2
	7.5	VXT-40A-2#	3.5	8	5.5	5.5	5.5	2
	11	VXT-56A-2#	8	14	5.5	8	14	2
	15	VXT-69A-2#	14	22	5.5	14	14	2
	18.5	VXT-88A-2#	14	38 ^{*7}	8	22	22	2
22	VXT-115A-2#	22	38 ^{*7}	8	22	38 ^{*7}	2	
Three-phase 400 V	0.4	VXT-2A-4#	2	2	2	2	2	2
	0.75	VXT-4A-4#	2	2	2	2	2	2
	1.5	VXT-6A-4#	2	2	2	2	2	2
	2.2	VXT-7A-4# ^{*10}	2	2	2	2	2	2
	3.7	VXT-12A-4# ^{*10}	2	2	2	2	2	2
	5.5	VXT-22A-4#	2	2	2	2	2	2
	7.5	VXT-29A-4#	2	3.5	2	2	2	2
	11	VXT-37A-4#	2	5.5	3.5	3.5	3.5	2
	15	VXT-44A-4#	3.5	8	5.5	3.5	5.5	2
	18.5	VXT-59A-4#	5.5	14	5.5	5.5	8 ^{*1}	2
	22	VXT-72A-4#	8 ^{*1}	14	5.5	8 ^{*1}	14	2
	30	VXT-85A-4#	14	22	8	14	14	-
	37	VXT-105A-4#	14	38	8	22	22	-
	45	VXT-139A-4#	22	38	8	22	38	-
	55	VXT-168A-4#	38	60	14	38	38	-
	75	VXT-203A-4#	60	-	14	60	60	-
	90	VXT-240A-4#	60	-	14	60	100	-
	110	VXT-290A-4#	100	-	22	100	-	-
132	VXT-361A-4#	100	-	22	-	-	-	
160	VXT-415A-4#	-	-	22	-	-	-	
200	VXT-520A-4#	-	-	38	-	-	-	
220	VXT-590A-4#	-	-	38	-	-	-	
Single-phase	0.4	VXT-3A-1#	2	2	2	2	2	2
	0.75	VXT-5A-1#	2	2	2	2	2	2
	1.5	VXT-8A-1#	2	2	2	2	2	2
	2.2	VXT-11A-1#	2	3.5	2	2	2	2

The recommended wire sizes for the main circuit terminals assume using 60°C IV wire.

*1 For compatible crimped terminals, please use model 8-L6 by JST Mfg. Co., Ltd. or equivalent.

*10 ND-spec.

2) Ambient temperature: Below 40°C, Wire type: 75°C wire

Table 2.2-13 Recommended Wire Sizes, Ambient temperature: Below 40°C, Wire type: 75°C wire (continued)

ND Mode, Ambient temperature: Below 40°C, Wire type: 75°C wire

Power System	Std Applicable Motor (kW)	Inverter type	Recommended wire size (mm ²)					
			Main power supply input [L1/R, L2/S, L3/T]		Ground terminal [zG]	Inverter output [U, V, W]	For DC reactor connection [P1, P(+)]	For braking resistor connection [P(+), DB]
			With DC reactor	Without DC reactor				
Three-phase 400 V	0.75	VXT-2A-4#	2	2	2	2	2	2
	1.5	VXT-4A-4#	2	2	2	2	2	2
	2.2	VXT-6A-4#	2	2	2	2	2	2
	3.0	VXT-7A-4# *10	2	2	2	2	2	2
	5.5	VXT-12A-4# *10	2	2	2	2	2	2
	11	VXT-22A-4#	2	3.5	3.5	2	2	2
	15	VXT-29A-4#	2	5.5	5.5	2	3.5	2
	18.5	VXT-37A-4#	3.5	8	5.5	3.5	5.5	2
	22	VXT-44A-4#	5.5	8	5.5	5.5	5.5	2
	30	VXT-59A-4#	8*1	14	8*1	8*1	14	2
	37	VXT-72A-4#	14	14	8*1	14	14	2
	45	VXT-85A-4#	14	22	8	14	22	-
	55	VXT-105A-4#	22	38	14	22	38	-
	75	VXT-139A-4#	38	-	14	38	38	-
	90	VXT-168A-4#	38	-	14	38	60	-
	110	VXT-203A-4#	60	-	22	60	100	-
	132	VXT-240A-4#	100	-	22	100	100	-
	160	VXT-290A-4#	100	-	22	100	150*3	-
200	VXT-361A-4#	150	-	38	150	200	-	
220	VXT-415A-4#	150	-	38	150	200	-	
280	VXT-520A-4#	200	-	38	250	325	-	
315	VXT-590A-4#	250	-	60	250	325	-	

HD Mode, Ambient temperature: Below 40°C, Wire type: 75°C wire

Power System	Std Applicable Motor (kW)	Inverter type	Recommended wire size (mm ²)					
			Main power supply input [L1/R, L2/S, L3/T]		Ground terminal [zG]	Inverter output [U, V, W]	For DC reactor connection [P1, P(+)]	For braking resistor connection [P(+), DB]
			With DC reactor	Without DC reactor				
Three-phase 400 V	0.75	VXT-2A-4#	2	2	2	2	2	2
	1.1	VXT-4A-4#	2	2	2	2	2	2
	2.2	VXT-6A-4#	2	2	2	2	2	2
	3.0	VXT-7A-4#	2	2	2	2	2	2
	5.5	VXT-12A-4#	2	2	2	2	2	2
	7.5	VXT-22A-4#	2	2	2	2	2	2
	11	VXT-29A-4#	2	3.5	3.5	2	2	2
	15	VXT-37A-4#	2	5.5	5.5	3.5	3.5	2
	18.5	VXT-44A-4#	3.5	8	5.5	3.5	5.5	2
	22	VXT-59A-4#	5.5	8*1	5.5	5.5	5.5	2
	30	VXT-72A-4#	8*1	14	8*1	8*1	14	2
	37	VXT-85A-4#	14	14	8	14	14	-
	45	VXT-105A-4#	14	22	8	14	22	-
	55	VXT-139A-4#	22	38	14	22	38	-
	75	VXT-168A-4#	38	-	14	38	38	-
	90	VXT-203A-4#	38	-	14	60	60	-
	110	VXT-240A-4#	60	-	22	60	100	-
	132	VXT-290A-4#	100	-	22	100	100	-
160	VXT-361A-4#	100	-	22	100	150	-	
200	VXT-415A-4#	150	-	38	150	200	-	
220	VXT-520A-4#	150	-	38	150	200	-	
250	VXT-590A-4#	200	-	38	200	250	-	

The recommended wire sizes for the main circuit terminals assume using 75°C 600 V HIV wire.

*1 For compatible crimped terminals, please use model 8-L6 by JST Mfg. Co., Ltd. or equivalent.

*3 For compatible crimped terminals, please use model CB150-10 by JST Mfg. Co., Ltd. or equivalent.

Table 2.2-14 Recommended Wire Sizes, Ambient temperature: Below 40°C, Wire type: 75°C wire (continued)

HND Mode, Ambient temperature: Below 40°C, Wire type: 75°C wire

Power System	Std Applicable Motor (kW)	Inverter type	Recommended wire size (mm ²)					
			Main power supply input [L1/R, L2/S, L3/T]		Ground terminal [zG]	Inverter output [U, V, W]	For DC reactor connection [P1, P(+)]	For braking resistor connection [P(+), DB]
			With DC reactor	Without DC reactor				
Three-phase 200 V	0.75	VXT-4A-2#	2	2	2	2	2	2
	1.5	VXT-6A-2#	2	2	2	2	2	2
	2.2	VXT-10A-2#	2	2	2	2	2	2
	3.0	VXT-12A-2# *10	2	2	2	2	2	2
	5.5	VXT-20A-2# *10	2	3.5	3.5	2	2	2
	7.5	VXT-30A-2#	2	5.5	5.5	3.5	3.5	2
	11	VXT-40A-2#	5.5	8	5.5	5.5	5.5	2
	15	VXT-56A-2#	8	14	5.5	8	14	2
	18.5	VXT-69A-2#	14	22	8	14	14	2
	22	VXT-88A-2#	14	22	8	14	22	2
30	VXT-115A-2#	22	38 ^{*7}	14	22	38 ^{*7}	2	
Three-phase 400 V	0.75	VXT-2A-4#	2	2	2	2	2	2
	1.1	VXT-4A-4#	2	2	2	2	2	2
	2.2	VXT-6A-4#	2	2	2	2	2	2
	3.0	VXT-7A-4# *10	2	2	2	2	2	2
	5.5	VXT-12A-4# *10	2	2	2	2	2	2
	7.5	VXT-22A-4#	2	2	2	2	2	2
	11	VXT-29A-4#	2	3.5	3.5	2	2	2
	15	VXT-37A-4#	2	5.5	3.5	3.5	3.5	2
	18.5	VXT-44A-4#	5.5	8	5.5	5.5	5.5	2
	22	VXT-59A-4#	5.5	8 ^{*1}	5.5	5.5	5.5	2
	30	VXT-72A-4#	8 ^{*1}	14	8 ^{*1}	8 ^{*1}	14	2
	37	VXT-85A-4#	14	14	8	14	14	-
	45	VXT-105A-4#	14	22	8	14	22	-
	55	VXT-139A-4#	22	38	14	22	38	-
	75	VXT-168A-4#	38	-	14	38	38	-
	90	VXT-203A-4#	38	-	14	60	60	-
	110	VXT-240A-4#	60	-	22	60	100	-
	132	VXT-290A-4#	100	-	22	100	100	-
160	VXT-361A-4#	100	-	22	100	150	-	
200	VXT-415A-4#	150	-	38	150	200	-	
220	VXT-520A-4#	150	-	38	150	200	-	
280	VXT-590A-4#	200	-	38	250	325	-	

The recommended wire sizes for the main circuit terminals assume using 75°C 600V HIV wire.

*1 For compatible crimped terminals, please use model 8-L6 by JST Mfg. Co., Ltd. or equivalent.

*4 For compatible crimped terminals, please use model R5.5-6 by JST Mfg. Co., Ltd. or equivalent.

*7 For compatible crimped terminals, please use model 38-6 by JST Mfg. Co., Ltd. or equivalent.

*10 ND-spec.

Table 2.2-15 Recommended Wire Sizes, Ambient temperature: Below 40°C, Wire type: 75°C wire (continued)

HHD Mode, Ambient temperature: Below 40°C, Wire type: 75°C wire

Power System	Std Applicable Motor (kW)	Inverter type	Recommended wire size (mm ²)					
			Main power supply input [L1/R, L2/S, L3/T]		Ground terminal [zG]	Inverter output [U, V, W]	For DC reactor connection [P1, P(+)]	For braking resistor connection [P(+), DB]
			With DC reactor	Without DC reactor				
Three-phase 200 V	0.4	VXT-4A-2#	2	2	2	2	2	2
	0.75	VXT-6A-2#	2	2	2	2	2	2
	1.5	VXT-10A-2#	2	2	2	2	2	2
	2.2	VXT-12A-2#	2	2	2	2	2	2
	3.7	VXT-20A-2#	2	2	2	2	2	2
	5.5	VXT-30A-2#	2	3.5	3.5	2	2	2
	7.5	VXT-40A-2#	2	5.5	5.5	3.5	3.5	2
	11	VXT-56A-2#	5.5	8	5.5	5.5	5.5	2
	15	VXT-69A-2#	8	14	5.5	8	14	2
	18.5	VXT-88A-2#	14	22	8	14	14	2
22	VXT-115A-2#	14	22	8	14	22	2	
Three-phase 400 V	0.4	VXT-2A-4#	2	2	2	2	2	2
	0.75	VXT-4A-4#	2	2	2	2	2	2
	1.5	VXT-6A-4#	2	2	2	2	2	2
	2.2	VXT-7A-4#	2	2	2	2	2	2
	3.7	VXT-12A-4#	2	2	2	2	2	2
	5.5	VXT-22A-4#	2	2	2	2	2	2
	7.5	VXT-29A-4#	2	2	2	2	2	2
	11	VXT-37A-4#	2	3.5	3.5	2	2	2
	15	VXT-44A-4#	2	5.5	5.5	3.5	3.5	2
	18.5	VXT-59A-4#	3.5 ^{*4}	8 ^{*1}	5.5	3.5 ^{*4}	5.5	2
	22	VXT-72A-4#	5.5	8 ^{*1}	5.5	5.5	5.5	2
	30	VXT-85A-4#	8	14	8	8	14	-
	37	VXT-105A-4#	14	14	8	14	14	-
	45	VXT-139A-4#	14	22	8	14	22	-
	55	VXT-168A-4#	22	38	14	22	38	-
	75	VXT-203A-4#	38	-	14	38	38	-
	90	VXT-240A-4#	38	-	14	60	60	-
	110	VXT-290A-4#	60	-	22	60	100	-
132	VXT-361A-4#	100	-	22	100	100	-	
160	VXT-415A-4#	100	-	22	100	150	-	
200	VXT-520A-4#	150	-	38	150	200	-	
220	VXT-590A-4#	150	-	38	150	200	-	
Single-phase 200 V	0.4	VXT-3A-1#	2	2	2	2	2	2
	0.75	VXT-5A-1#	2	2	2	2	2	2
	1.5	VXT-8A-1#	2	2	2	2	2	2
	2.2	VXT-11A-1#	2	2	2	2	2	2

The recommended wire sizes for the main circuit terminals assume using 75°C 600V HIV wire.

*1 For compatible crimped terminals, please use model 8-L6 by JST Mfg. Co., Ltd. or equivalent.

*4 For compatible crimped terminals, please use model R5.5-6 by JST Mfg. Co., Ltd. or equivalent.

3) Ambient temperature: Below 40°C, Wire type: 90°C wire

Table 2.2-16 Recommended Wire Sizes, Ambient temperature: Below 40°C, Wire type: 90°C wire

ND Mode, Ambient temperature: Below 40°C, Wire type: 90°C wire

Power System	Std Applicable Motor (kW)	Inverter type	Recommended wire size (mm ²)					
			Main power supply input [L1/R, L2/S, L3/T]		Ground terminal [zG]	Inverter output [U, V, W]	For DC reactor connection [P1, P(+)]	For braking resistor connection [P(+), DB]
			With DC reactor	Without DC reactor				
Three-phase 400 V	0.75	VXT-2A-4#	2	2	2	2	2	2
	1.5	VXT-4A-4#	2	2	2	2	2	2
	2.2	VXT-6A-4#	2	2	2	2	2	2
	3.0	VXT-7A-4#	2	2	2	2	2	2
	5.5	VXT-12A-4#	2	2	2	2	2	2
	11	VXT-22A-4#	2	2	3.5	2	2	2
	15	VXT-29A-4#	2	3.5	5.5	2	3.5	2
	18.5	VXT-37A-4#	3.5	5.5	5.5	3.5	3.5	2
	22	VXT-44A-4#	3.5	5.5	5.5	3.5	5.5	2
	30	VXT-59A-4#	5.5	8 ^{*1}	8 ^{*1}	5.5	8 ^{*1}	2
	37	VXT-72A-4#	8 ^{*1}	14	8 ^{*1}	8 ^{*1}	14	2
	45	VXT-85A-4#	14	22	8	14	14	-
	55	VXT-105A-4#	14	22	14	14	22	-
	75	VXT-139A-4#	22	-	14	22	38	-
	90	VXT-168A-4#	38	-	14	38	38	-
	110	VXT-203A-4#	38	-	22	38	60	-
	132	VXT-240A-4#	60	-	22	60	100	-
	160	VXT-290A-4#	100	-	22	100	100	-
	200	VXT-361A-4#	100	-	38	100	150	-
220	VXT-415A-4#	150	-	38	150	150	-	
280	VXT-520A-4#	150	-	38	200	250	-	
315	VXT-590A-4#	200	-	60	200	250	-	

HD Mode, Ambient temperature: Below 40°C, Wire type: 90°C wire

Power System	Std Applicable Motor (kW)	Inverter type	Recommended wire size (mm ²)					
			Main power supply input [L1/R, L2/S, L3/T]		Ground terminal [zG]	Inverter output [U, V, W]	For DC reactor connection [P1, P(+)]	For braking resistor connection [P(+), DB]
			With DC reactor	Without DC reactor				
Three-phase 400 V	0.75	VXT-2A-4#	2	2	2	2	2	2
	1.1	VXT-4A-4#	2	2	2	2	2	2
	2.2	VXT-6A-4#	2	2	2	2	2	2
	3.0	VXT-7A-4#	2	2	2	2	2	2
	5.5	VXT-12A-4#	2	2	2	2	2	2
	7.5	VXT-22A-4#	2	2	2	2	2	2
	11	VXT-29A-4#	2	2	3.5	2	2	2
	15	VXT-37A-4#	2	3.5	5.5	2	3.5	2
	18.5	VXT-44A-4#	3.5	5.5	5.5	3.5	3.5	2
	22	VXT-59A-4#	3.5 ^{*4}	5.5	5.5	3.5 ^{*4}	5.5	2
	30	VXT-72A-4#	5.5	8 ^{*1}	8 ^{*1}	5.5	8 ^{*1}	2
	37	VXT-85A-4#	8	14	8	8	14	-
	45	VXT-105A-4#	14	22	8	14	14	-
	55	VXT-139A-4#	14	22	14	14	22	-
	75	VXT-168A-4#	22	-	14	38	38	-
	90	VXT-203A-4#	38	-	14	38	38	-
	110	VXT-240A-4#	38	-	22	60	60	-
	132	VXT-290A-4#	60	-	22	60	100	-
	160	VXT-361A-4#	100	-	22	100	100	-
200	VXT-415A-4#	100	-	38	100	150	-	
220	VXT-520A-4#	150	-	38	150	150	-	
250	VXT-590A-4#	150	-	38	150	200	-	

The recommended wire sizes for the main circuit terminals assume using 90°C 600 V FSLC wire.

*1 For compatible crimped terminals, please use model 8-L6 by JST Mfg. Co., Ltd. or equivalent.

*4 For compatible crimped terminals, please use model R5.5-6 by JST Mfg. Co., Ltd. or equivalent.

Table 2.2-17 Recommended Wire Sizes, Ambient temperature: Below 40°C, Wire type: 90°C wire (continued)

HND Mode, Ambient temperature: Below 40°C, Wire type: 90°C wire

Power System	Std Applicable Motor (kW)	Inverter type	Recommended wire size (mm ²)					
			Main power supply input [L1/R, L2/S, L3/T]		Ground terminal [zG]	Inverter output [U, V, W]	For DC reactor connection [P1, P(+)]	For braking resistor connection [P(+), DB]
			With DC reactor	Without DC reactor				
Three-phase 200 V	0.75	VXT-4A-2#	2	2	2	2	2	2
	1.1	VXT-6A-2#	2	2	2	2	2	2
	2.2	VXT-10A-2#	2	2	2	2	2	2
	3.0	VXT-12A-2# *10	2	2	2	2	2	2
	5.5	VXT-20A-2# *10	2	2	3.5	2	2	2
	7.5	VXT-30A-2#	2	3.5	5.5	2	3.5	2
	11	VXT-40A-2#	3.5	5.5	5.5	3.5	5.5	2
	15	VXT-56A-2#	5.5	14	5.5	5.5	8	2
	18.5	VXT-69A-2#	8	14	8	8	14	2
	22	VXT-88A-2#	14	14	8	14	14	2
30	VXT-115A-2#	22	38 ^{*7}	14	22	22	2	
Three-phase 400 V	0.75	VXT-2A-4#	2	2	2	2	2	2
	1.1	VXT-4A-4#	2	2	2	2	2	2
	2.2	VXT-6A-4#	2	2	2	2	2	2
	3.0	VXT-7A-4# *10	2	2	2	2	2	2
	5.5	VXT-12A-4# *10	2	2	2	2	2	2
	7.5	VXT-22A-4#	2	2	2	2	2	2
	11	VXT-29A-4#	2	2	3.5	2	2	2
	15	VXT-37A-4#	2	3.5	3.5	3.5	3.5	2
	18.5	VXT-44A-4#	3.5	5.5	5.5	3.5	3.5	2
	22	VXT-59A-4#	3.5 ^{*4}	5.5	5.5	3.5 ^{*4}	5.5	2
	30	VXT-72A-4#	5.5	8 ^{*1}	8 ^{*1}	5.5	8 ^{*1}	2
	37	VXT-85A-4#	8	14	8	8	14	-
	45	VXT-105A-4#	14	22	8	14	14	-
	55	VXT-139A-4#	14	22	14	14	22	-
	75	VXT-168A-4#	22	-	14	38	38	-
	90	VXT-203A-4#	38	-	14	38	38	-
	110	VXT-240A-4#	38	-	22	60	60	-
	132	VXT-290A-4#	60	-	22	60	100	-
160	VXT-361A-4#	100	-	22	100	100	-	
200	VXT-415A-4#	100	-	38	100	150	-	
220	VXT-520A-4#	150	-	38	150	150	-	
280	VXT-590A-4#	150	-	38	200	250	-	

The recommended wire sizes for the main circuit terminals assume using 90°C 600 V FSLC wire.

*1 For compatible crimped terminals, please use model 8-L6 by JST Mfg. Co., Ltd. or equivalent.

*4 For compatible crimped terminals, please use model R5.5-6 by JST Mfg. Co., Ltd. or equivalent.

*7 For compatible crimped terminals, please use model 38-6 by JST Mfg. Co., Ltd. or equivalent.

*10 ND-spec.

Table 2.2-18 Recommended Wire Sizes, Ambient temperature: Below 40°C, Wire type: 90°C wire (continued)

HHD Mode, Ambient temperature: Below 40°C, Wire type: 90°C wire

Power System	Std Applicable Motor (kW)	Inverter type	Recommended wire size (mm ²)					
			Main power supply input [L1/R, L2/S, L3/T]		Ground terminal [zG]	Inverter output [U, V, W]	For DC reactor connection [P1, P(+)]	For braking resistor connection [P(+), DB]
			With DC reactor	Without DC reactor				
Three-phase 200 V	0.4	VXT-4A-2#	2	2	2	2	2	2
	0.75	VXT-6A-2#	2	2	2	2	2	2
	1.5	VXT-10A-2#	2	2	2	2	2	2
	2.2	VXT-12A-2#	2	2	2	2	2	2
	3.7	VXT-20A-2#	2	2	2	2	2	2
	5.5	VXT-30A-2#	2	2	3.5	2	2	2
	7.5	VXT-40A-2#	2	3.5	5.5	2	3.5	2
	11	VXT-56A-2#	3.5	5.5	5.5	3.5	5.5	2
	15	VXT-69A-2#	5.5	14	5.5	5.5	8	2
	18.5	VXT-88A-2#	8	14	8	8	14	2
22	VXT-115A-2#	14	14	8	14	14	2	
Three-phase 400 V	0.4	VXT-2A-4#	2	2	2	2	2	2
	0.75	VXT-4A-4#	2	2	2	2	2	2
	1.5	VXT-6A-4#	2	2	2	2	2	2
	2.2	VXT-7A-4#	2	2	2	2	2	2
	3.7	VXT-12A-4#	2	2	2	2	2	2
	5.5	VXT-22A-4#	2	2	2	2	2	2
	7.5	VXT-29A-4#	2	2	2	2	2	2
	11	VXT-37A-4#	2	2	3.5	2	2	2
	15	VXT-44A-4#	2	3.5	5.5	2	3.5	2
	18.5	VXT-59A-4#	3.5 ^{*4}	5.5	5.5	3.5 ^{*4}	3.5 ^{*4}	2
	22	VXT-72A-4#	3.5 ^{*4}	5.5	5.5	3.5 ^{*4}	5.5	2
	30	VXT-85A-4#	5.5	8	8	5.5	8	-
	37	VXT-105A-4#	8	14	8	8	14	-
	45	VXT-139A-4#	14	22	8	14	14	-
	55	VXT-168A-4#	14	22	14	14	22	-
	75	VXT-203A-4#	22	-	14	38	38	-
	90	VXT-240A-4#	38	-	14	38	38	-
110	VXT-290A-4#	38	-	22	60	60	-	
132	VXT-361A-4#	60	-	22	60	100	-	
160	VXT-415A-4#	100	-	22	100	100	-	
200	VXT-520A-4#	100	-	38	100	150	-	
220	VXT-590A-4#	150	-	38	150	150	-	
Single-phase 200 V	0.4	VXT-3A-1#	2	2	2	2	2	2
	0.75	VXT-5A-1#	2	2	2	2	2	2
	1.5	VXT-8A-1#	2	2	2	2	2	2
	2.2	VXT-11A-1#	2	2	2	2	2	2

The recommended wire sizes for the main circuit terminals assume using 90°C 600 V FSLC wire.

*1 For compatible crimped terminals, please use model 8-L6 by JST Mfg. Co., Ltd. or equivalent.

*4 For compatible crimped terminals, please use model R5.5-6 by JST Mfg. Co., Ltd. or equivalent.

4) Ambient temperature: Below 50°C, Wire type: 60°C wire

Table 2.2-19 Recommended Wire Sizes, Ambient temperature: Below 50°C, Wire type: 60°C wire

ND Mode, Ambient temperature: Below 50°C, Wire type: 60°C wire

Power System	Std Applicable Motor (kW)	Inverter type	Recommended wire size (mm ²)					
			Main power supply input (Note 1) [L1/R, L2/S, L3/T]		Ground terminal (Note 1) [zG]	Inverter output (Note 1) [U, V, W]	For DC reactor connection (Note 1) [P1, P(+)]	For braking resistor connection [P(+), DB]
			With DC reactor	Without DC reactor				
Three-phase 400 V	0.75	VXT-2A-4#	2	2	2	2	2	2
	1.5	VXT-4A-4#	2	2	2	2	2	2
	2.2	VXT-6A-4#	2	2	2	2	2	2
	3.0	VXT-7A-4#	2	2	2	2	2	2
	5.5	VXT-12A-4#	2	3.5	2	2	2	2
	11	VXT-22A-4#	3.5	5.5	3.5	3.5	3.5	2
	15	VXT-29A-4#	5.5	14	5.5	5.5	5.5	2
	18.5	VXT-37A-4#	8	14	5.5	8	5.5	2
	22	VXT-44A-4#	8	14	5.5	14	8	2
	30	VXT-59A-4#	14	22	8 ^{*1}	14	22	2
	37	VXT-72A-4#	22	38	8 ^{*1}	22	38	2
	45	VXT-85A-4#	38	38	8	38	38	-
	55	VXT-105A-4#	38	60	14	38	60	-
	75	VXT-139A-4#	60	-	14	60	100 ^{*2}	-
	90	VXT-168A-4#	100 ^{*2}	-	14	100 ^{*2}	100 ^{*2}	-
	110	VXT-203A-4#	100	-	22	100	-	-
	132	VXT-240A-4#	-	-	22	-	-	-
	160	VXT-290A-4#	-	-	22	-	-	-
	200	VXT-361A-4#	-	-	38	-	-	-
220	VXT-415A-4#	-	-	38	-	-	-	
280	VXT-520A-4#	-	-	38	-	-	-	
315	VXT-590A-4#	-	-	60	-	-	-	

HD Mode, Ambient temperature: Below 50°C, Wire type: 60°C wire

Power System	Std Applicable Motor (kW)	Inverter type	Recommended wire size (mm ²)					
			Main power supply input (Note 1) [L1/R, L2/S, L3/T]		Ground terminal (Note 1) [zG]	Inverter output (Note 1) [U, V, W]	For DC reactor connection (Note 1) * [P1, P(+)]	For braking resistor connection [P(+), DB]
			With DC reactor	Without DC reactor				
Three-phase 400 V	0.75	VXT-2A-4#	2	2	2	2	2	2
	1.1	VXT-4A-4#	2	2	2	2	2	2
	2.2	VXT-6A-4#	2	2	2	2	2	2
	3.0	VXT-7A-4#	2	2	2	2	2	2
	5.5	VXT-12A-4#	2	3.5	2	2	2	2
	7.5	VXT-22A-4#	2	3.5	2	2	2	2
	11	VXT-29A-4#	3.5	5.5	3.5	3.5	3.5	2
	15	VXT-37A-4#	5.5	14	5.5	5.5	5.5	2
	18.5	VXT-44A-4#	8	14	5.5	8	5.5	2
	22	VXT-59A-4#	8 ^{*1}	14	5.5	14	14	2
	30	VXT-72A-4#	14	22	8 ^{*1}	14	22	2
	37	VXT-85A-4#	22	38	8	22	38	-
	45	VXT-105A-4#	38	38	8	38	38	-
	55	VXT-139A-4#	38	60	14	38	60	-
	75	VXT-168A-4#	60	-	14	60	100 ^{*2}	-
	90	VXT-203A-4#	100	-	14	100	100	-
	110	VXT-240A-4#	100	-	22	100	-	-
	132	VXT-290A-4#	-	-	22	-	-	-
	160	VXT-361A-4#	-	-	22	-	-	-
200	VXT-415A-4#	-	-	38	-	-	-	
220	VXT-520A-4#	-	-	38	-	-	-	
250	VXT-590A-4#	-	-	38	-	-	-	

Note 1) The rated current must be reduced for operation (Rated current x 80%). Recommended wire sizes assume these conditions.

The recommended wire sizes for the main circuit terminals assume using 60°C IV wire.

*1 For compatible crimped terminals, please use model 8-L6 by JST Mfg. Co., Ltd. or equivalent.

*2 For compatible crimped terminals, please use model CB100-S8 by JST Mfg. Co., Ltd. or equivalent.

Table 2.2-20 Recommended Wire Sizes, Ambient temperature: Below 50°C, Wire type: 60°C wire (continued)

HND Mode, Ambient temperature: Below 50°C, Wire type: 60°C wire

Power System	Std Applicable Motor (kW)	Inverter type	Recommended wire size (mm ²)					
			Main power supply input [L1/R, L2/S, L3/T]		Ground terminal [zG]	Inverter output [U, V, W]	For DC reactor connection [P1, P(+)]	For braking resistor connection [P(+), DB]
			With DC reactor	Without DC reactor				
Three-phase 200 V	0.75	VXT-4A-2#	2	2	2	2	2	2
	1.1	VXT-6A-2#	2	2	2	2	2	2
	2.2	VXT-10A-2#	2	2	2	2	2	2
	3.0	VXT-12A-2# *10	2	3.5	2	2	2	2
	5.5	VXT-20A-2# *10	3.5	8	3.5	3.5	5.5	2
	7.5	VXT-30A-2#	8	14	5.5	8	14	2
	11	VXT-40A-2#	14	22 ³	5.5	14	22 ³	2
	15	VXT-56A-2#	22	38 ⁴	5.5	22	38 ⁴	2
	18.5	VXT-69A-2#	38 ⁴	60 ⁵	8	38 ⁴	38 ⁴	2
	22	VXT-88A-2#	38 ⁷	60 ⁸	8	38 ⁷	60 ⁸	2
30	VXT-115A-2#	60 ⁸	100 ⁹	14	60 ⁸	100 ⁹	2	
Three-phase 400 V	0.75	VXT-2A-4#	2	2	2	2	2	2
	1.1	VXT-4A-4#	2	2	2	2	2	2
	2.2	VXT-6A-4#	2	2	2	2	2	2
	3.0	VXT-7A-4# *10	2	2	2	2	2	2
	5.5	VXT-12A-4# *10	2	3.5	2	2	2	2
	7.5	VXT-22A-4#	2	5.5	2	3.5	3.5	2
	11	VXT-29A-4#	5.5	8	3.5	5.5	5.5	2
	15	VXT-37A-4#	8	14	3.5	8	14	2
	18.5	VXT-44A-4#	14	22	5.5	14	14	2
	22	VXT-59A-4#	14	22	5.5	14	22	2
	30	VXT-72A-4#	22	38	8 ¹	22	38	2
	37	VXT-85A-4#	38	60	8	38	38	-
	45	VXT-105A-4#	38	60	8	38	60	-
	55	VXT-139A-4#	60	100 ²	14	60	60	-
	75	VXT-168A-4#	100 ²	-	14	100 ²	100 ²	-
	90	VXT-203A-4#	100	-	14	-	-	-
	110	VXT-240A-4#	-	-	22	-	-	-
	132	VXT-290A-4#	-	-	22	-	-	-
160	VXT-361A-4#	-	-	22	-	-	-	
200	VXT-415A-4#	-	-	38	-	-	-	
220	VXT-520A-4#	-	-	38	-	-	-	
280	VXT-590A-4#	-	-	38	-	-	-	

The recommended wire sizes for the main circuit terminals assume using 60°C IV wire.

- *1 For compatible crimped terminals, please use model 8-L6 by JST Mfg. Co., Ltd. or equivalent.
- *2 For compatible crimped terminals, please use model CB100-S8 by JST Mfg. Co., Ltd. or equivalent.
- *3 For compatible crimped terminals, please use model 22-S5 by JST Mfg. Co., Ltd. or equivalent.
- *4 For compatible crimped terminals, please use model 38-S6 by JST Mfg. Co., Ltd. or equivalent.
- *5 For compatible crimped terminals, please use model CB60-S6 by JST Mfg. Co., Ltd. or equivalent.
- *7 For compatible crimped terminals, please use model 38-6 by JST Mfg. Co., Ltd. or equivalent.
- *8 For compatible crimped terminals, please use model 60-6 by JST Mfg. Co., Ltd. or equivalent.
- *9 For compatible crimped terminals, please use model CB100-S8 by JST Mfg. Co., Ltd. or equivalent.
- *10 ND-spec.

Table 2.2-21 Recommended Wire Sizes, Ambient temperature: Below 50°C, Wire type: 60°C wire (continued)

HHD Mode, Ambient temperature: Below 50°C, Wire type: 60°C wire

Power System	Std Applicable Motor (kW)	Inverter type	Recommended wire size (mm ²)					
			Main power supply input [L1/R, L2/S, L3/T]		Ground terminal [zG]	Inverter output [U, V, W]	For DC reactor connection [P1, P(+)]	For braking resistor connection [P(+), DB]
			With DC reactor	Without DC reactor				
Three-phase 200 V	0.4	VXT-4A-2#	2	2	2	2	2	2
	0.75	VXT-6A-2#	2	2	2	2	2	2
	1.5	VXT-10A-2#	2	2	2	2	2	2
	2.2	VXT-12A-2#	2	2	2	2	2	2
	3.7	VXT-20A-2#	2	5.5	2	3.5	3.5	2
	5.5	VXT-30A-2#	5.5	8	3.5	5.5	5.5	2
	7.5	VXT-40A-2#	8	14	5.5	8	14	2
	11	VXT-56A-2#	14	22	5.5	14	22	2
	15	VXT-69A-2#	22	38	5.5	22	38	2
	18.5	VXT-88A-2#	38 ^{*7}	60 ^{*8}	8	38 ^{*7}	38 ^{*7}	2
22	VXT-115A-2#	38 ^{*7}	60 ^{*8}	8	38 ^{*7}	60 ^{*8}	2	
Three-phase 400 V	0.4	VXT-2A-4#	2	2	2	2	2	2
	0.75	VXT-4A-4#	2	2	2	2	2	2
	1.5	VXT-6A-4#	2	2	2	2	2	2
	2.2	VXT-7A-4#	2	2	2	2	2	2
	3.7	VXT-12A-4#	2	2	2	2	2	2
	5.5	VXT-22A-4#	2	3.5	2	2	2	2
	7.5	VXT-29A-4#	2	5.5	2	3.5	3.5	2
	11	VXT-37A-4#	5.5	8	3.5	5.5	5.5	2
	15	VXT-44A-4#	8	14	5.5	8	14	2
	18.5	VXT-59A-4#	14	22	5.5	14	14	2
	22	VXT-72A-4#	14	22	5.5	14	22	2
	30	VXT-85A-4#	22	38	8	22	38	-
	37	VXT-105A-4#	38	60	8	38	38	-
	45	VXT-139A-4#	38	60	8	38	60	-
	55	VXT-168A-4#	60	100 ^{*2}	14	60	60	-
	75	VXT-203A-4#	100	-	14	100	100	-
	90	VXT-240A-4#	100	-	14	-	-	-
	110	VXT-290A-4#	-	-	22	-	-	-
132	VXT-361A-4#	-	-	22	-	-	-	
160	VXT-415A-4#	-	-	22	-	-	-	
200	VXT-520A-4#	-	-	38	-	-	-	
220	VXT-590A-4#	-	-	38	-	-	-	
Single-phase 200 V	0.4	VXT-3A-1#	2	2	2	2	2	2
	0.75	VXT-5A-1#	2	2	2	2	2	2
	1.5	VXT-8A-1#	2	3.5	2	2	2	2
	2.2	VXT-11A-1#	3.5	5.5	2	2	3.5	2

The recommended wire sizes for the main circuit terminals assume using 60°C IV wire.

- *1 For compatible crimped terminals, please use model 8-L6 by JST Mfg. Co., Ltd. or equivalent.
- *2 For compatible crimped terminals, please use model CB100-S8 by JST Mfg. Co., Ltd. or equivalent.
- *3 For compatible crimped terminals, please use model 22-S5 by JST Mfg. Co., Ltd. or equivalent.
- *4 For compatible crimped terminals, please use model 38-S6 by JST Mfg. Co., Ltd. or equivalent.
- *5 For compatible crimped terminals, please use model CB60-S6 by JST Mfg. Co., Ltd. or equivalent.
- *7 For compatible crimped terminals, please use model 38-6 by JST Mfg. Co., Ltd. or equivalent.
- *8 For compatible crimped terminals, please use model 60-6 by JST Mfg. Co., Ltd. or equivalent.

5) Ambient temperature: Below 50°C, Wire type: 75°C wire

Table 2.2-22 Recommended Wire Sizes, Ambient temperature: Below 50°C, Wire type: 75°C wire

ND Mode, Ambient temperature: Below 50°C, Wire type: 75°C wire

Power System	Std Applicable Motor (kW)	Inverter type	Recommended wire size (mm ²)					
			Main power supply input (Note 1) [L1/R, L2/S, L3/T]		Ground terminal (Note 1) [zG]	Inverter output (Note 1) [U, V, W]	For DC reactor connection (Note 1) [P1, P(+)]	For braking resistor connection [P(+), DB]
			With DC reactor	Without DC reactor				
Three-phase 400 V	0.75	VXT-2A-4#	2	2	2	2	2	2
	1.5	VXT-4A-4#	2	2	2	2	2	2
	2.2	VXT-6A-4#	2	2	2	2	2	2
	3.0	VXT-7A-4#	2	2	2	2	2	2
	5.5	VXT-12A-4#	2	2	2	2	2	2
	11	VXT-22A-4#	2	3.5	3.5	2	2	2
	15	VXT-29A-4#	2	5.5	5.5	2	2	2
	18.5	VXT-37A-4#	3.5	5.5	5.5	3.5	3.5	2
	22	VXT-44A-4#	5.5	8	5.5	5.5	5.5	2
	30	VXT-59A-4#	8 ^{*1}	14	8 ^{*1}	8 ^{*1}	14	2
	37	VXT-72A-4#	8 ^{*1}	14	8 ^{*1}	14	14	2
	45	VXT-85A-4#	14	22	8	14	22	-
	55	VXT-105A-4#	22	38	14	22	22	-
	75	VXT-139A-4#	38	-	14	38	38	-
	90	VXT-168A-4#	38	-	14	38	60	-
	110	VXT-203A-4#	60	-	22	60	60	-
	132	VXT-240A-4#	60	-	22	60	100	-
	160	VXT-290A-4#	100	-	22	100	150 ^{*3}	-
	200	VXT-361A-4#	150	-	38	150	150	-
220	VXT-415A-4#	150	-	38	150	200	-	
280	VXT-520A-4#	200	-	38	200	250	-	
315	VXT-590A-4#	250	-	60	250	325	-	

HD Mode, Ambient temperature: Below 50°C, Wire type: 75°C wire

Power System	Std Applicable Motor (kW)	Inverter type	Recommended wire size (mm ²)					
			Main power supply input (Note 1) [L1/R, L2/S, L3/T]		Ground terminal (Note 1) [zG]	Inverter output (Note 1) [U, V, W]	For DC reactor connection (Note 1) [P1, P(+)]	For braking resistor connection [P(+), DB]
			With DC reactor	Without DC reactor				
Three-phase 400 V	0.75	VXT-2A-4#	2	2	2	2	2	2
	1.1	VXT-4A-4#	2	2	2	2	2	2
	2.2	VXT-6A-4#	2	2	2	2	2	2
	3.0	VXT-7A-4#	2	2	2	2	2	2
	5.5	VXT-12A-4#	2	2	2	2	2	2
	7.5	VXT-22A-4#	2	2	2	2	2	2
	11	VXT-29A-4#	2	3.5	3.5	2	2	2
	15	VXT-37A-4#	2	5.5	5.5	3.5	2	2
	18.5	VXT-44A-4#	3.5	5.5	5.5	3.5	3.5	2
	22	VXT-59A-4#	5.5	8 ^{*1}	5.5	5.5	5.5	2
	30	VXT-72A-4#	8 ^{*1}	14	8 ^{*1}	8 ^{*1}	14	2
	37	VXT-85A-4#	8	14	8	14	14	-
	45	VXT-105A-4#	14	22	8	14	22	-
	55	VXT-139A-4#	22	38	14	22	22	-
	75	VXT-168A-4#	38	-	14	38	38	-
	90	VXT-203A-4#	38	-	14	38	60	-
	110	VXT-240A-4#	60	-	22	60	60	-
	132	VXT-290A-4#	60	-	22	100	100	-
	160	VXT-361A-4#	100	-	22	100	150	-
200	VXT-415A-4#	150	-	38	150	150	-	
220	VXT-520A-4#	150	-	38	150	200	-	
250	VXT-590A-4#	150	-	38	200	250	-	

Note 1) The rated current must be reduced for operation (Rated current x 80%). Recommended wire sizes assume these conditions.

The recommended wire sizes for the main circuit terminals assume using 75°C 600 V HIV wire.

*1 For compatible crimped terminals, please use model 8-L6 by JST Mfg. Co., Ltd. or equivalent.

*3 For compatible crimped terminals, please use model CB150-10 by JST Mfg. Co., Ltd. or equivalent.

Table 2.2-23 Recommended Wire Sizes, Ambient temperature: Below 50°C, Wire type: 75°C wire (continued)

HND Mode, Ambient temperature: Below 50°C, Wire type: 75°C wire

Power System	Std Applicable Motor (kW)	Inverter type	Recommended wire size (mm ²)					
			Main power supply input [L1/R, L2/S, L3/T]		Ground terminal [zG]	Inverter output [U, V, W]	For DC reactor connection [P1, P(+)]	For braking resistor connection [P(+), DB]
			With DC reactor	Without DC reactor				
Three-phase 200 V	0.75	VXT-4A-2#	2	2	2	2	2	2
	1.1	VXT-6A-2#	2	2	2	2	2	2
	2.2	VXT-10A-2#	2	2	2	2	2	2
	3.0	VXT-12A-2# *10	2	2	2	2	2	2
	5.5	VXT-20A-2# *10	2	3.5	3.5	2	3.5	2
	7.5	VXT-30A-2#	3.5	5.5	5.5	3.5	5.5	2
	11	VXT-40A-2#	5.5	14	5.5	5.5	8	2
	15	VXT-56A-2#	14	14	5.5	14	14	2
	18.5	VXT-69A-2#	14	22	8	14	22	2
	22	VXT-88A-2#	22	38 ⁷	8	22	22	2
30	VXT-115A-2#	38 ⁷	60 ⁸	14	38 ⁷	38 ⁷	2	
Three-phase 400 V	0.75	VXT-2A-4#	2	2	2	2	2	2
	1.1	VXT-4A-4#	2	2	2	2	2	2
	2.2	VXT-6A-4#	2	2	2	2	2	2
	3.0	VXT-7A-4# *10	2	2	2	2	2	2
	5.5	VXT-12A-4# *10	2	2	2	2	2	2
	7.5	VXT-22A-4#	2	2	2	2	2	2
	11	VXT-29A-4#	2	3.5	3.5	2	3.5	2
	15	VXT-37A-4#	3.5	5.5	3.5	5.5	5.5	2
	18.5	VXT-44A-4#	5.5	8	5.5	5.5	5.5	2
	22	VXT-59A-4#	5.5	14	5.5	8 ¹¹	8 ¹¹	2
	30	VXT-72A-4#	14	14	8 ¹¹	14	14	2
	37	VXT-85A-4#	14	22	8	14	22	-
	45	VXT-105A-4#	22	38	8	22	22	-
	55	VXT-139A-4#	22	38	14	38	38	-
	75	VXT-168A-4#	38	-	14	60	60	-
	90	VXT-203A-4#	60	-	14	60	100	-
	110	VXT-240A-4#	100	-	22	100	100	-
	132	VXT-290A-4#	100	-	22	100	150 ³	-
160	VXT-361A-4#	150	-	22	150	150	-	
200	VXT-415A-4#	150	-	38	200	250	-	
220	VXT-520A-4#	200	-	38	200	250	-	
280	VXT-590A-4#	250	-	38	325	200×2	-	

Note 1) The rated current must be reduced for operation (Rated current x 80%). Recommended wire sizes assume these conditions.

The recommended wire sizes for the main circuit terminals assume using 75°C 600 V HIV wire.

- *1 For compatible crimped terminals, please use model 8-L6 by JST Mfg. Co., Ltd. or equivalent.
- *3 For compatible crimped terminals, please use model CB150-10 by JST Mfg. Co., Ltd. or equivalent.
- *7 For compatible crimped terminals, please use model 38-6 by JST Mfg. Co., Ltd. or equivalent.
- *8 For compatible crimped terminals, please use model 60-6 by JST Mfg. Co., Ltd. or equivalent.
- *10 ND-spec.

Table 2.2-24 Recommended Wire Sizes, Ambient temperature: Below 50°C, Wire type: 75°C wire (continued)

HHD Mode, Ambient temperature: Below 50°C, Wire type: 75°C wire

Power System	Std Applicable Motor (kW)	Inverter type	Recommended wire size (mm ²)					
			Main power supply input [L1/R, L2/S, L3/T]		Ground terminal [zG]	Inverter output [U, V, W]	For DC reactor connection [P1, P(+)]	For braking resistor connection [P(+), DB]
			With DC reactor	Without DC reactor				
Three-phase 200 V	0.4	VXT-4A-2#	2	2	2	2	2	2
	0.75	VXT-6A-2#	2	2	2	2	2	2
	1.5	VXT-10A-2#	2	2	2	2	2	2
	2.2	VXT-12A-2#	2	2	2	2	2	2
	3.7	VXT-20A-2#	2	2	2	2	2	2
	5.5	VXT-30A-2#	2	3.5	3.5	3.5	3.5	2
	7.5	VXT-40A-2#	3.5	5.5	5.5	3.5	5.5	2
	11	VXT-56A-2#	5.5	14	5.5	8	8	2
	15	VXT-69A-2#	14	14	5.5	14	14	2
	18.5	VXT-88A-2#	14	22	8	14	22	2
22	VXT-115A-2#	22	38 ^{*7}	8	22	22	2	
Three-phase 400 V	0.4	VXT-2A-4#	2	2	2	2	2	2
	0.75	VXT-4A-4#	2	2	2	2	2	2
	1.5	VXT-6A-4#	2	2	2	2	2	2
	2.2	VXT-7A-4#	2	2	2	2	2	2
	3.7	VXT-12A-4#	2	2	2	2	2	2
	5.5	VXT-22A-4#	2	2	2	2	2	2
	7.5	VXT-29A-4#	2	2	2	2	2	2
	11	VXT-37A-4#	2	3.5	3.5	2	3.5	2
	15	VXT-44A-4#	3.5	5.5	5.5	3.5	5.5	2
	18.5	VXT-59A-4#	5.5	8 ^{*1}	5.5	5.5	5.5	2
	22	VXT-72A-4#	5.5	14	5.5	8 ^{*1}	8 ^{*1}	2
	30	VXT-85A-4#	14	14	8	14	14	-
	37	VXT-105A-4#	14	22	8	14	22	-
	45	VXT-139A-4#	22	38	8	22	22	-
	55	VXT-168A-4#	22	38	14	38	38	-
	75	VXT-203A-4#	38	-	14	60	60	-
	90	VXT-240A-4#	60	-	14	60	100	-
110	VXT-290A-4#	100	-	22	100	100	-	
132	VXT-361A-4#	100	-	22	100	150	-	
160	VXT-415A-4#	150	-	22	150	150	-	
200	VXT-520A-4#	150	-	38	200	250	-	
220	VXT-590A-4#	200	-	38	200	250	-	
Single-phase 200 V	0.4	VXT-3A-1#	2	2	2	2	2	2
	0.75	VXT-5A-1#	2	2	2	2	2	2
	1.5	VXT-8A-1#	2	2	2	2	2	2
	2.2	VXT-11A-1#	2	3.5	2	2	2	2

The recommended wire sizes for the main circuit terminals assume using 75°C 600 V HIV wire.

- *1 For compatible crimped terminals, please use model 8-L6 by JST Mfg. Co., Ltd. or equivalent.
- *3 For compatible crimped terminals, please use model CB150-10 by JST Mfg. Co., Ltd. or equivalent.
- *7 For compatible crimped terminals, please use model 38-6 by JST Mfg. Co., Ltd. or equivalent.

6) Ambient temperature: Below 50°C, Wire type: 90°C wire

Table 2.2-25 Recommended Wire Sizes, Ambient temperature: Below 50°C, Wire type: 90°C wire

ND Mode, Ambient temperature: Below 50°C, Wire type: 90°C wire

Power System	Std Applicable Motor (kW)	Inverter type	Recommended wire size (mm ²)					
			Main power supply input (Note 1) [L1/R, L2/S, L3/T]		Ground terminal (Note 1) [zG]	Inverter output (Note 1) [U, V, W]	For DC reactor connection (Note 1) [P1, P(+)]	For braking resistor connection [P(+), DB]
			With DC reactor	Without DC reactor				
Three-phase 400 V	0.75	VXT-2A-4#	2	2	2	2	2	2
	1.5	VXT-4A-4#	2	2	2	2	2	2
	2.2	VXT-6A-4#	2	2	2	2	2	2
	3.0	VXT-7A-4#	2	2	2	2	2	2
	5.5	VXT-12A-4#	2	2	2	2	2	2
	11	VXT-22A-4#	2	3.5	3.5	2	2	2
	15	VXT-29A-4#	2	5.5	5.5	2	3.5	2
	18.5	VXT-37A-4#	3.5	5.5	5.5	3.5	5.5	2
	22	VXT-44A-4#	5.5	8	5.5	5.5	5.5	2
	30	VXT-59A-4#	5.5	8 ^{*1}	8 ^{*1}	5.5	5.5	2
	37	VXT-72A-4#	5.5	14	8 ^{*1}	8 ^{*1}	8 ^{*1}	2
	45	VXT-85A-4#	8	14	8	8	14	-
	55	VXT-105A-4#	14	22	14	14	14	-
	75	VXT-139A-4#	22	-	14	22	38	-
	90	VXT-168A-4#	22	-	14	38	38	-
	110	VXT-203A-4#	38	-	22	38	60	-
	132	VXT-240A-4#	60	-	22	60	60	-
	160	VXT-290A-4#	60	-	22	60	100	-
	200	VXT-361A-4#	100	-	38	100	150	-
220	VXT-415A-4#	100	-	38	100	150	-	
280	VXT-520A-4#	150	-	38	150	200	-	
315	VXT-590A-4#	150	-	60	200	250	-	

Note 1) The rated current must be reduced for operation (Rated current x 80%). Recommended wire sizes assume these conditions.

HD Mode, Ambient temperature: Below 50°C, Wire type: 90°C wire

Power System	Std Applicable Motor (kW)	Inverter type	Recommended wire size (mm ²)					
			Main power supply input (Note 1) [L1/R, L2/S, L3/T]		Ground terminal (Note 1) [zG]	Inverter output (Note 1) [U, V, W]	For DC reactor connection (Note 1) [P1, P(+)]	For braking resistor connection [P(+), DB]
			With DC reactor	Without DC reactor				
Three-phase 400 V	0.75	VXT-2A-4#	2	2	2	2	2	2
	1.1	VXT-4A-4#	2	2	2	2	2	2
	2.2	VXT-6A-4#	2	2	2	2	2	2
	3.0	VXT-7A-4#	2	2	2	2	2	2
	5.5	VXT-12A-4#	2	2	2	2	2	2
	7.5	VXT-22A-4#	2	2	2	2	2	2
	11	VXT-29A-4#	2	3.5	3.5	2	2	2
	15	VXT-37A-4#	2	5.5	5.5	2	3.5	2
	18.5	VXT-44A-4#	3.5	5.5	5.5	3.5	5.5	2
	22	VXT-59A-4#	3.5 ^{*4}	5.5	5.5	3.5 ^{*4}	3.5 ^{*4}	2
	30	VXT-72A-4#	5.5	8 ^{*1}	8 ^{*1}	5.5	5.5	2
	37	VXT-85A-4#	5.5	14	8	8	8	-
	45	VXT-105A-4#	8	14	8	14	14	-
	55	VXT-139A-4#	14	22	14	14	14	-
	75	VXT-168A-4#	22	-	14	22	38	-
	90	VXT-203A-4#	22	-	14	38	38	-
	110	VXT-240A-4#	38	-	22	38	60	-
	132	VXT-290A-4#	60	-	22	60	60	-
	160	VXT-361A-4#	60	-	22	60	100	-
200	VXT-415A-4#	100	-	38	100	150	-	
220	VXT-520A-4#	100	-	38	100	150	-	
250	VXT-590A-4#	150	-	38	150	150	-	

Note 1) The rated current must be reduced for operation (Rated current x 80%). Recommended wire sizes assume these conditions.

The recommended wire sizes for the main circuit terminals assume using 90°C 600 V FSLC wire.

*1 For compatible crimped terminals, please use model 8-L6 by JST Mfg. Co., Ltd. or equivalent.

*4 For compatible crimped terminals, please use model R5.5-6 by JST Mfg. Co., Ltd. or equivalent.

Table 2.2-26 Recommended Wire Sizes, Ambient temperature: Below 50°C, Wire type: 90°C wire (continued)

HND Mode, Ambient temperature: Below 50°C, Wire type: 90°C wire

Power System	Std Applicable Motor (kW)	Inverter type	Recommended wire size (mm ²)					
			Main power supply input [L1/R, L2/S, L3/T]		Ground terminal [zG]	Inverter output [U, V, W]	For DC reactor connection [P1, P(+)]	For braking resistor connection [P(+), DB]
			With DC reactor	Without DC reactor				
Three-phase 200 V	0.75	VXT-4A-2#	2	2	2	2	2	2
	1.1	VXT-6A-2#	2	2	2	2	2	2
	2.2	VXT-10A-2#	2	2	2	2	2	2
	3.0	VXT-12A-2# *10	2	2	2	2	2	2
	5.5	VXT-20A-2# *10	2	3.5	3.5	2	2	2
	7.5	VXT-30A-2#	2	5.5	5.5	2	3.5	2
	11	VXT-40A-2#	5.5	8	5.5	3.5	5.5	2
	15	VXT-56A-2#	8	14	5.5	5.5	14	2
	18.5	VXT-69A-2#	14	14	8	8	14	2
	22	VXT-88A-2#	14	22	8	14	22	2
30	VXT-115A-2#	22	38 ^{*7}	14	22	38 ^{*7}	2	
Three-phase 400 V	0.75	VXT-2A-4#	2	2	2	2	2	2
	1.1	VXT-4A-4#	2	2	2	2	2	2
	2.2	VXT-6A-4#	2	2	2	2	2	2
	3.0	VXT-7A-4# *10	2	2	2	2	2	2
	5.5	VXT-12A-4# *10	2	2	2	2	2	2
	7.5	VXT-22A-4#	2	2	2	2	2	2
	11	VXT-29A-4#	2	3.5	3.5	2	2	2
	15	VXT-37A-4#	2	5.5	3.5	3.5	3.5	2
	18.5	VXT-44A-4#	3.5	5.5	5.5	3.5	5.5	2
	22	VXT-59A-4#	5.5	8 ^{*1}	5.5	5.5	5.5	2
	30	VXT-72A-4#	8 ^{*1}	14	8 ^{*1}	8 ^{*1}	8 ^{*1}	2
	37	VXT-85A-4#	8	14	8	14	14	-
	45	VXT-105A-4#	14	22	8	14	22	-
	55	VXT-139A-4#	22	38	14	22	22	-
	75	VXT-168A-4#	38	-	14	38	38	-
	90	VXT-203A-4#	38	-	14	38	60	-
	110	VXT-240A-4#	60	-	22	60	60	-
	132	VXT-290A-4#	60	-	22	100	100	-
160	VXT-361A-4#	100	-	22	100	150	-	
200	VXT-415A-4#	150	-	38	150	150	-	
220	VXT-520A-4#	150	-	38	150	200	-	
280	VXT-590A-4#	200	-	38	200	250	-	

The recommended wire sizes for the main circuit terminals assume using 90°C 600 V FSLC wire.

*1 For compatible crimped terminals, please use model 8-L6 by JST Mfg. Co., Ltd. or equivalent.

*4 For compatible crimped terminals, please use model R5.5-6 by JST Mfg. Co., Ltd. or equivalent.

*7 For compatible crimped terminals, please use model 38-6 by JST Mfg. Co., Ltd. or equivalent.

*10 ND-spec

Table 2.2-27 Recommended Wire Sizes, Ambient temperature: Below 50°C, Wire type: 90°C wire (continued)

HHD Mode, Ambient temperature: Below 50°C, Wire type: 90°C wire

Power System	Std Applicable Motor (kW)	Inverter type	Recommended wire size (mm ²)					
			Main power supply input [L1/R, L2/S, L3/T]		Ground terminal [zG]	Inverter output [U, V, W]	For DC reactor connection [P1, P(+)]	For braking resistor connection [P(+), DB]
			With DC reactor	Without DC reactor				
Three-phase 200 V	0.4	VXT-4A-2#	2	2	2	2	2	2
	0.75	VXT-6A-2#	2	2	2	2	2	2
	1.5	VXT-10A-2#	2	2	2	2	2	2
	2.2	VXT-12A-2# *10	2	2	2	2	2	2
	3.7	VXT-20A-2# *10	2	2	2	2	2	2
	5.5	VXT-30A-2#	2	3.5	3.5	2	2	2
	7.5	VXT-40A-2#	2	5.5	5.5	3.5	3.5	2
	11	VXT-56A-2#	5.5	8	5.5	5.5	5.5	2
	15	VXT-69A-2#	8	14	5.5	8	14	2
	18.5	VXT-88A-2#	14	14	8	14	14	2
22	VXT-115A-2#	14	22	8	14	22	2	
Three-phase 400 V	0.4	VXT-2A-4#	2	2	2	2	2	2
	0.75	VXT-4A-4#	2	2	2	2	2	2
	1.5	VXT-6A-4#	2	2	2	2	2	2
	2.2	VXT-7A-4#	2	2	2	2	2	2
	3.7	VXT-12A-4#	2	2	2	2	2	2
	5.5	VXT-22A-4#	2	2	2	2	2	2
	7.5	VXT-29A-4#	2	2	2	2	2	2
	11	VXT-37A-4#	2	3.5	3.5	2	2	2
	15	VXT-44A-4#	2	5.5	5.5	2	3.5	2
	18.5	VXT-59A-4#	3.5 ^{*4}	5.5	5.5	3.5 ^{*4}	5.5	2
	22	VXT-72A-4#	5.5	8 ^{*1}	5.5	5.5	5.5	2
	30	VXT-85A-4#	8	14	8	8	8	-
	37	VXT-105A-4#	8	14	8	14	14	-
	45	VXT-139A-4#	14	22	8	14	22	-
	55	VXT-168A-4#	22	38	14	22	22	-
	75	VXT-203A-4#	38	-	14	38	38	-
	90	VXT-240A-4#	38	-	14	38	60	-
	110	VXT-290A-4#	60	-	22	60	60	-
132	VXT-361A-4#	60	-	22	100	100	-	
160	VXT-415A-4#	100	-	22	100	150	-	
200	VXT-520A-4#	150	-	38	150	150	-	
220	VXT-590A-4#	150	-	38	150	200	-	
Single-phase 200 V	0.4	VXT-3A-1#	2	2	2	2	2	2
	0.75	VXT-5A-1#	2	2	2	2	2	2
	1.5	VXT-8A-1#	2	2	2	2	2	2
	2.2	VXT-11A-1#	2	2	2	2	2	2

The recommended wire sizes for the main circuit terminals assume using 90°C 600 V FSLC wire.

*1 For compatible crimped terminals, please use model 8-L6 by JST Mfg. Co., Ltd. or equivalent.

*4 For compatible crimped terminals, please use model R5.5-6 by JST Mfg. Co., Ltd. or equivalent.

[4] Description of terminal functions (main circuit terminal)

Classification	Terminal symbol	Terminal name	Specification
Main circuit	L1/R, L2/S, L3/T	Main power input	Terminals to connect Three-phase power source.
	L1/L, L2/N	Main power input	Terminals to connect Single-phase power source.
	U, V, W	Inverter output	Terminals to connect Three-phase motors.
	P (+), P1	For direct current reactor connection	Terminals to connect DC reactor (DCR) for power factor enhancement. It must be connected in the following cases: ND mode: Types VXT-139A-4 or above. HD/HND mode: Types VXT-168A-4 or above. HHD mode: Types VXT-203A-4 or above.
	P (+), N (-)	For direct current bus connection	Terminals to connect direct current intermediate circuit of other inverters and PWM converters.
	P (+), DB	For braking resistor connection	Terminals to connect a braking resistor (optional). Wiring length: Below 5 meters. (Types VXT-115A-2 / VXT-72A-4 / VXT-11A-1 or below)
	zG	For inverter chassis (case) grounding	Grounding terminal for inverter chassis (case).
	R0, T0	Auxiliary power input for control circuit	When it is desired to retain the alarm signal for the activation of the protective function even inverter main power supply shut off or when continuous display of the keypad is desired, connect this terminal to the power supply. (Types VXT-88A-4 / VXT-59A-4 or above)
	R1, T1	Auxiliary power input for fan	Ordinarily, these terminals do not need to be connected. Connect these terminals to AC power supply when operating with direct current power input (such as in combination with PWM converters). (Types VXT-203A-4 or above)

Follow the sequence below when wiring.

- (1) Inverter ground terminal (zG)
- (2) Inverter output terminals (U, V, W), motor ground terminal (zG)
- (3) Direct current reactor connection terminals (P1, P(+))*
- (4) Braking resistor connection terminals (P(+), DB)*
- (5) Direct current bus connection terminals (P(+), N(-))*
- (6) Main power supply input terminals (L1/R, L2/S, L3/T) or (L1/L, L2/N)
- (7) Auxiliary power input for control circuit (R0, T0) *

*: Connect if necessary.

Connect in the order (1), (2), (6), (3), (4), (5), (7) for the following models.

VXT-10 to 20A-2#, VXT-2 to 12A-4#, VXT-8 to 11A-1#

(1) Main power source input terminals L1/R, L2/S, L3/T (Three-phase input) or L1/L, L2/N (Single-phase input)

Connect the Three-phase power source for Three-phase input model. Connect the Single-phase power source for Single-phase input model.

- 1) For safety, confirm that the circuit breaker (MCCB) or the magnetic contactor (MC) is OFF prior to wiring the power lines.
- 2) Connect the power lines (L1/R, L2/S, L3/T) or (L1/L, L2/N) to MCCB or residual-current-operated protective device (RCD)/ the earth leakage breaker (ELCB)*, or connect via MC if necessary. The phase sequence of the power lines and the inverter do not need to be matched.

*: With overcurrent protection



In emergencies such as when the inverter protective function is activated, disconnecting the inverter from the power source to prevent magnification of failure or accident may be desired. Installation of an MC

which allows manual disconnection of the power source is recommended.

(2) Inverter output terminals U, V, W, motor ground terminal zG

- 1) Connect the Three-phase motor terminals U, V, and W while matching the phase sequence.
- 2) Connect the ground line of the outputs (U, V, W) to the ground terminal (zG).

Note When multiple combinations of inverters and motors exist, do not use multi-core cables for the purpose of bundling the various wires.

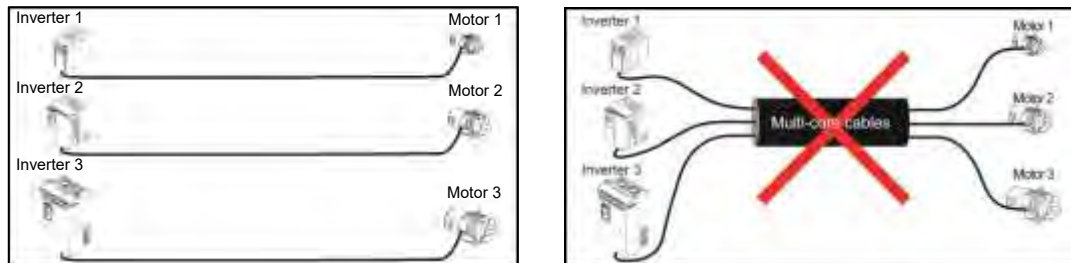

(3) Direct current reactor connection terminals P1, P(+)

Connect the direct current reactor (DCR) for power factor enhancement.

- 1) Remove the shorting bar from terminals P1-P(+).
(Types VXT-203A-4 or above will not have the shorting bar connected.)
- 2) Connect the P1, P(+) terminals to the direct current reactor (option).

Note

- Keep the wiring length below 10 meters.
- Do not remove the shorting bar if the direct current reactor is not used.
- When the capacity of the motor to be used is above 75 kW, always connect the direct current reactor.
- Direct current reactors do not have to be connected when connecting PWM converters.

⚠ WARNING

Always connect the direct current reactor (option) when the power supply transformer capacity is above 500 kVA and is over 10 times the rated capacity of the inverter.

Risk of fire exists.

**(4) Braking resistor connection terminals P(+), DB
(Types VXT-115A-2 / VXT-72A-4 / VXT-11A-1 or below)**

- 1) Connect terminals P(+), DB of the inverter to braking resistor terminals (option).
- 2) Mount the inverter main body and the braking resistor such that the wiring length will be less than 5m (16ft) and route the two wires twisted or in contact with each other (parallel).

⚠ WARNING

Do not connect to terminals other than P(+)-DB when connecting braking resistors.

Risk of fire exists.

(5) Direct current bus terminals P(+), N(-)

1) Connecting the braking unit/braking resistor (option)

Inverter type	Braking transistor	Additional instruments for connection (option)	Instruments connected/connection terminals
Types VXT-85A-4 or below	Not equipped	Braking unit	Inverter (P(+), N(-)) - Braking unit (P(+), N(-))
		Braking resistor	Braking unit (P(+), R, DB) - Braking resistor (P, DB)

Braking units are necessary when using braking resistors for types VXT-85A-4 or above.

Connect terminals P(+), N(-) of the braking unit to the inverter terminals P(+), N(-). Mount the equipment such that the wiring length is below 5m (16ft) and route the two wires twisted or in contact with each other (parallel).

Connect the terminals P(+), R, DB of the braking unit to terminals P(+), DB of the braking resistor. Mount the equipment such that the wiring length is below 10m (33ft) and route the two wires twisted or in contact with each other (parallel).

For details such as other wirings, refer to the user's manual for the braking unit.

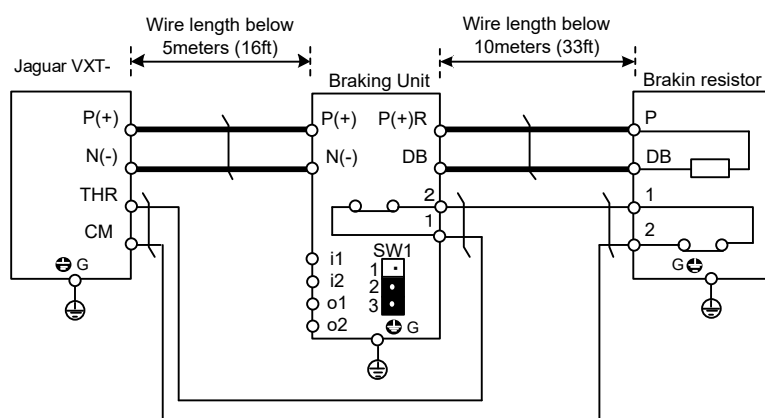

Figure 2.2-9

2) Connection of other instruments

The direct current intermediate circuit of other inverters and PWM converters can be connected.

(For connection with the PWM converter consult IMO.)

(6) Inverter ground terminal G

This terminal is the ground terminal for the inverter chassis (case). Always connect to ground for safety and as a countermeasure for noise. To prevent accidents such as electric shock and fire, the electrical safety standards require grounding construction for metallic frames in electric instruments.

Follow the steps below in connecting the ground terminal on the power supply side.

- 1) Ground the inverter in compliance with the national or local electric code.
- 2) The grounding wire size should be as described before in this chapter, with large surface area, and as short as possible.

(7) Auxiliary power input terminals for control circuit R0, T0 (Types VXT-88A-2 / VXT-59A-4 or above)

The inverter can be operated without power input to the auxiliary power input terminals for control circuit. However, the inverter output signals and the keypad display will be shut off when the inverter main power is shut off and the control power source is lost.

When it is desired to retain the alarm signal for the activation of the protective function even inverter main power supply shut off, or when continuous display of the keypad is desired, connect these terminals to the power supply. When the inverter input side has a magnetic contactor (MC), wire from the input side (primary side) of the magnetic contactor (MC).

Terminal rating: AC 200 to 240 V, 50/60 Hz, maximum current 1.0 A (200 V series)
AC 380 to 480 V, 50/60 Hz, maximum current 0.5 A (400 V series)



When using the earth leakage breaker, connect terminals R0, T0 to the output side of the earth leakage breaker.

When connections are made to the input side of the earth leakage breaker, the earth leakage breaker will malfunction because the inverter input is three-phase and the terminals R0, T0 are single phase. When connecting to terminals R0, T0 to the input side of the earth leakage breaker, make sure that the connection is done through an insulating transformer or, alternatively, through the auxiliary B contacts of the magnetic contactor as shown in the figure below.

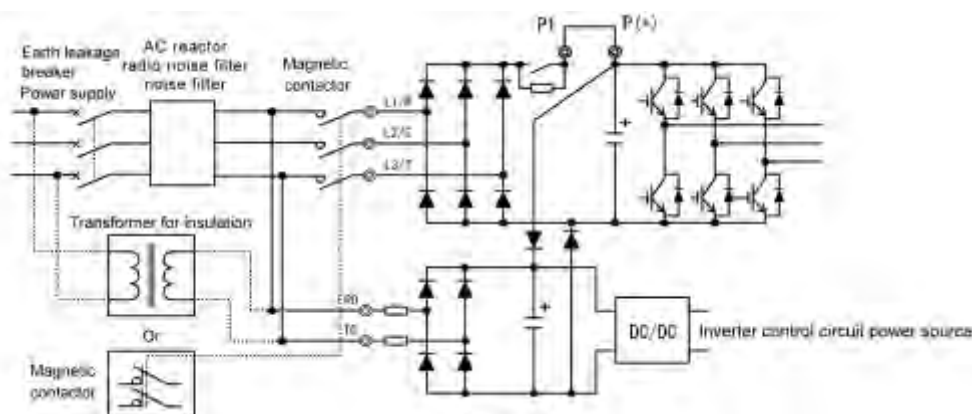

Figure 2.2-10 Connection of the Earth Leakage Breaker



When connecting with the PWM converter, do not connect power source directly to the inverter's auxiliary power input terminals (R0, T0) for control circuit. Insert an insulating transformer or the auxiliary B contacts of a magnetic contactor on the power supply side.

On connection examples for the PWM converter side consult IMO.

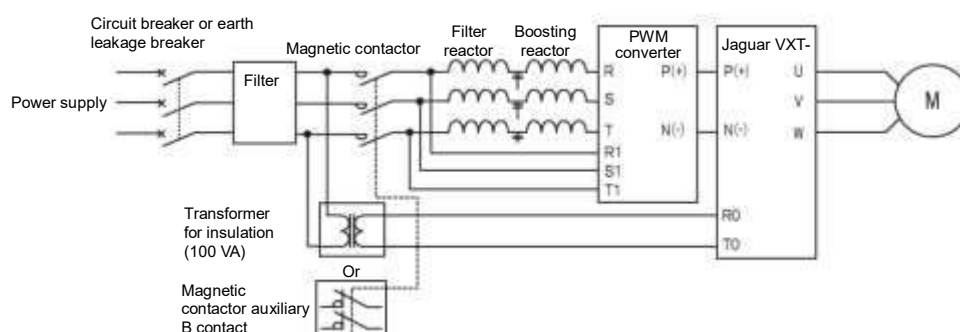

Figure 2.2-11 Example of connection of R0, T0 terminals in combination with PWM converter

(8) Auxiliary power input terminals for fan R1, T1 (Types VXT-203-4 or above)

These terminals are equipped on types VXT-203A-4# or below, but are not used ordinarily.

Connect the AC power source when using direct current power supply input (such as in combination with PWM converters).

Also switch the fan power supply switching connectors "CN R", "CN W".

Terminal rating: AC 380 to 440 V/50 Hz, 380 to 480 V/60 Hz, maximum current 1.0 A (400 V series)

2.2.6 Control circuit terminals (common to all models)

[1] Screw specifications and recommended wire size (control circuit terminals)

The screw specifications and wire sizes to be used for control circuit wiring are shown below.
The control circuit terminal board differs depending on the destination.

Table 2.2-28 Screw Specifications and Recommended Wire Sizes

Terminal symbol	Screw specification		Allowable wire sizes	Driver (shape of tip)	Removal size of wire cover 	Gauge size to insert wire
	Size	Tightening torque				
30A, 30B, 30C EN1, EN2	M3	0.5 N·m (4.43 lb-in)	0.14 to 1.5 mm ² (AWG26 to 16)	Minus (0.6mm×3.5mm)	6 mm (0.24 in)	A1*1
Others	M2	0.19 N·m (1.68 lb-in)	0.25 to 1 mm ² (AWG24 to 18)	Minus (0.4mm×2.5mm)	5 mm (0.20 in)	φ1.6

* Recommended rod terminal: Phoenix Contact Refer to Table 2.2-29 for details.

*1 Defined according to IEC/EN 60947-1.

Table 2.2-29 Recommended Rod Terminals

Screw size	Wire size	Type		
		With insulating collar	Without insulating collar	
M3	M2	0.25 mm ² (AWG24)	AI 0.25-6 BU	A 0.25-7
		0.34 mm ² (AWG22)	AI 0.34-6 TQ	A 0.34-7
		0.5 mm ² (AWG20)	AI 0.5-6 WH	A 0.5-6
	M3	0.75 mm ² (AWG18)	AI 0.75-6 GY	A 0.75-6
		1 mm ² (AWG18)	AI 1-6 RD	A 1-6
		1.5 mm ² (AWG16)	AI 1.5-6 BK	A 1.5-7

Note) When sizes exceeding the recommended wire sizes are used, the front cover may be pushed outward depending on the number of wires, causing erroneous operation of the keypad.

[2] Terminal layout diagram (control circuit terminal)

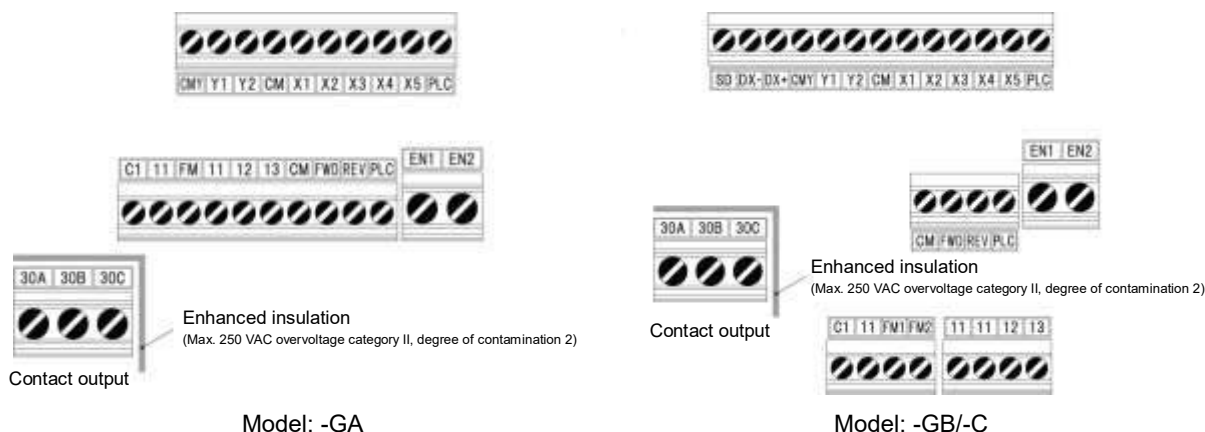

⚠ WARNING ⚠

The following terminals may have high voltage when the power is ON.
Control terminals: AUX-contact (30A, 30B, 30C)
Insulation level
Contact output – control circuit : Enhanced insulation (overvoltage category II, degree of contamination 2)
Risk of electric shock exists

[3] Description of terminal functions (control circuit terminal)

⚠ WARNING ⚠

Generally, the insulation for control signal lines is not enhanced. When the control signal lines come into direct contact with the main circuit live section, the insulation cover may be damaged. High voltage of the main circuit may be applied on the control signal lines, so exercise caution such that the main circuit live sections do not contact the control signal lines.

Risk of accidents and risk of electric shock exist.

⚠ CAUTION

Noise is generated by the inverter, motor, and wiring.

Exercise caution to prevent malfunction of peripheral sensors and instruments.

Risk of accidents exists.

Table 2.2-30 shows the functional explanations for the control circuit terminals. The connection method of the control circuit terminals differs depending on the functional code setting matching the purpose of inverter operation. Properly wire such that the impact of noise generated by the main circuit wiring is reduced.

Table 2.2-30 Functional Description of Control Circuit Terminals

Classification	Terminal symbol	Terminal name	Functional description
Analog input	[13]	Power supply for the potentiometer	The terminal is used for the power supply (DC+10 V 10 mA Max) for the external frequency command potentiometer (variable resistor: 1 to 5 kΩ). Connect variable resistors larger than 1/2 W.
	[12]	Analog setup voltage input	(1) Frequency is set up according to the external analog voltage input command value. Normal operation <ul style="list-style-type: none"> • DC0 to +10 V/0 to 100(%) (DC0 to +5 V/0 to 100%) • DC0 to ±10 V/0 to ±100(%) (DC0 to ±5 V/0 to ±100%) Reverse operation <ul style="list-style-type: none"> • DC+10 to 0V/0 to 100(%) (DC+5 to 0 V/0 to 100%) • DC±10 to 0V/0 to ±100(%) (DC±5 to 0V/0 to ±100%) (2) The terminal can be assigned to PID command, feedback signal of PID control, auxiliary frequency setup, ratio setup, torque limit setup, and analog input monitor aside from the frequency setup by analog input. (3) Hardware specification <ul style="list-style-type: none"> * Input impedance: 22 (kΩ) * Up to DC±15 V can be input. However, input exceeding DC±10 V will be recognized as DC±10 V.
	[C1]	Analog setup current input (C1 function)	(1) Frequency is set up according to the external analog current input command value. Normal operation <ul style="list-style-type: none"> • DC4 to 20 mA/0 to 100(%)/-100% to 0 to 100% • DC0 to 20 mA/0 to 100(%)/-100% to 0 to 100% Reverse operation <ul style="list-style-type: none"> • DC20 to 4 mA/0 to 100(%)/-100% to 0 to 100% • DC20 to 0 mA/0 to 100(%)/-100% to 0 to 100% (2) The terminal can be assigned to PID command, feedback signal of PID control, auxiliary frequency setup, ratio setup, torque limit setup, and analog input monitor aside from the frequency setup by analog input. (3) Hardware specification <ul style="list-style-type: none"> * Input impedance: 250 (Ω) * Up to DC 30 mA can be input. However, input exceeding DC 20 mA will be recognized as DC 20 mA.

Table 2.2-30 Functional Description of Control Circuit Terminals (continued)



Classification	Terminal symbol	Terminal name	Functional description
Analog input	[C1]	Analog setup voltage input (V2 function)	<p>(1) Frequency is set up according to the external analog voltage input command value. SW3 (refer to “2.2.8 Operating slide switches”) must be switched on the printed circuit board.</p> <p>Normal operation</p> <ul style="list-style-type: none"> • DC0 to +10 V/0 to 100% (DC0 to +5 V/0 to 100%) • DC0 to +10 V/-100 to 0 to 100% (DC0 to +5 V/-100 to 0 to 100%) <p>Reverse operation</p> <ul style="list-style-type: none"> • DC+10 to 0 V/0 to 100% (DC+5 V to 0 V/0 to 100%) • DC+10 to 0 V/-100 to 0 to 100% (DC+5 to 0 V/-100 to 0 to 100%) <p>(2) The terminal can be assigned to PID command, feedback signal of PID control, auxiliary frequency setup, ratio setup, torque limit setup, and analog input monitor aside from the frequency setup by analog input.</p> <p>(3) Hardware specification</p> <ul style="list-style-type: none"> * Input impedance: 22(kΩ) * Up to DC+15 V can be input. However, input exceeding DC+10 V will be recognized as DC+10 V.
		PTC thermistor input (PTC function)	<p>(1) PTC (Positive Temperature Coefficient) thermistor for motor protection can be connected. SW3 (C1/V2 Switch) and SW4 (PTC /AI Switch) (refer to “2.2.8 Operating slide switches”) must be switched on the printed circuit board.</p> <p>Figure 2.2-12 shows the internal circuit when SW3 and SW4 are set for PTC thermistor input. For details on SW3 and SW4, refer to “2.2.8 Operating slide switches”. When SW3 and SW4 are switched to the PTC side, function codes H26 and H27 also needs to be changed.</p>  <p style="text-align: center;">Figure 2.2-12 Internal circuit when SW4 is switched to PTC side</p>
		Analog input monitor (AI function)	<p>(1) The analog input monitor can be used to monitor the status of peripheral instruments using communication by inputting the analog signals of various sensors such as temperature sensors. Data can be converted to physical property values such as temperature and pressure by using display factors and shown on the keypad display.</p>
	[11]	Analog input common	<p>The terminal is the common terminal for analog input signals (terminals [12], [13], [C1]). The terminal is insulated from terminals [CM], [CMY].</p>
	<ul style="list-style-type: none"> • Use shielded lines and keep the wiring to the minimum as possible (below 20 meters) for control signals which are susceptible to external noise. Grounding the shielded lines is generally recommended, but if external induction noise is large, connecting to terminal 11 may reduce the noise. The shielded line increases the blocking effect. Always ground one end as shown in Figure 2.2-13. • When inserting a relay contact at analog input signal lines, use the twin contacts relay for small signals. Also, do not insert a relay to terminal 11. • When external analog signal generators are connected, the analog signal generator circuit may malfunction due to the noise created by the inverter. In these cases, connect ferrite core (toroidal shape or equivalent) to the output terminals of the analog signal generator or connect high frequency capacitors between the control signal lines, as shown in Figure 2.2-14.   <p style="text-align: center;">Figure 2.2-13 Connection Diagram for Shielded Lines Figure 2.2-14 Example of Noise Countermeasures</p>		

Table 2.2-30 Functional Description of Control Circuit Terminals (continued)

Classification	Terminal symbol	Terminal name	Functional description																									
Digital input	[X1]	Digital input 1	(1) Various signals (coast to a stop command, external alarm, multi-speed selection, etc) set up by function codes E01 to E05, E98 & E99 can be set up. For details, refer to Chapter 5 "FUNCTION CODES".																									
	[X2]	Digital input 2	(2) Input mode, sink/source can be switched using SW1. (Refer to "2.2.8 Operating slide switches")																									
	[X3]	Digital input 3	(3) The operating mode of the various digital input terminals when connected with terminal CM (sink mode) / PLC (source mode) can be switched to "ON when shorted with CM/PLC (active ON)" or "OFF when shorted with CM/PLC (active OFF)"																									
	[X4]	Digital input 4																										
	[X5]	Digital input 5/pulse train input	(4) Digital input terminal [X5] can be set up as a pulse train input terminal by changing the function code Maximum wiring length 20 meters Maximum input pulse																									
	[FWD]	Run forward command	30 kHz: When connected to open collector output pulse generator 100 kHz: When connected to complementary output pulse generator For function code settings, refer to Chapter 5 "FUNCTION CODES".																									
	[REV]	Run reverse command	<p><Digital input circuit specification></p>  <table border="1" data-bbox="901 853 1359 1176"> <thead> <tr> <th colspan="2">Item</th> <th>Minimum</th> <th>Maximum</th> </tr> </thead> <tbody> <tr> <td rowspan="2">Operating voltage (SINK)</td> <td>ON level</td> <td>0 V</td> <td>2 V</td> </tr> <tr> <td>OFF level</td> <td>22 V</td> <td>27 V</td> </tr> <tr> <td rowspan="2">Operating voltage (SOURCE)</td> <td>ON level</td> <td>22 V</td> <td>27 V</td> </tr> <tr> <td>OFF level</td> <td>0 V</td> <td>2 V</td> </tr> <tr> <td colspan="2">Operating current at ON (at input voltage 0 V) (for [X5] input terminal)</td> <td>2.5 mA (9.7 mA)</td> <td>5 mA (16 mA)</td> </tr> <tr> <td colspan="2">Allowable leak current at OFF</td> <td>-</td> <td>0.5 mA</td> </tr> </tbody> </table> <p style="text-align: center;">Figure 2.2-15 Digital Input Circuit</p>	Item		Minimum	Maximum	Operating voltage (SINK)	ON level	0 V	2 V	OFF level	22 V	27 V	Operating voltage (SOURCE)	ON level	22 V	27 V	OFF level	0 V	2 V	Operating current at ON (at input voltage 0 V) (for [X5] input terminal)		2.5 mA (9.7 mA)	5 mA (16 mA)	Allowable leak current at OFF		-
Item		Minimum	Maximum																									
Operating voltage (SINK)	ON level	0 V	2 V																									
	OFF level	22 V	27 V																									
Operating voltage (SOURCE)	ON level	22 V	27 V																									
	OFF level	0 V	2 V																									
Operating current at ON (at input voltage 0 V) (for [X5] input terminal)		2.5 mA (9.7 mA)	5 mA (16 mA)																									
Allowable leak current at OFF		-	0.5 mA																									
[EN1] [EN2]	Enable input	<p>(1) When terminals [EN1]-[PLC] or terminals [EN2]-[PLC] are OFF, the inverter output transistors stop switching (safe torque off: STO). Be sure to operate terminals [EN1] and [EN2] simultaneously; otherwise an <i>ecf</i> alarm is issued and the operation of the inverter will be disabled. To enable the Enable function, remove the shorting bar.</p> <p>(2) The input mode for terminals [EN1] and [EN2] is fixed to source. The mode cannot be switched to sink.</p> <p>(3) Short terminals [EN1]-[PLC] and [EN2] - [PLC] using shorting bars when the enable input function is not used (Keep the shorting bar connected).</p> <p><EN terminal circuit spec></p>  <table border="1" data-bbox="895 1608 1311 1809"> <thead> <tr> <th colspan="2">Item</th> <th>Min</th> <th>Max</th> </tr> </thead> <tbody> <tr> <td rowspan="2">Operating voltage (SOURCE)</td> <td>ON level</td> <td>22 V</td> <td>27 V</td> </tr> <tr> <td>OFF level</td> <td>0 V</td> <td>2 V</td> </tr> <tr> <td colspan="2">Operating current at ON (at input voltage 24 V)</td> <td>-</td> <td>4.5 mA</td> </tr> <tr> <td colspan="2">Allowable leak current at OFF</td> <td>-</td> <td>0.5 mA</td> </tr> </tbody> </table>	Item		Min	Max	Operating voltage (SOURCE)	ON level	22 V	27 V	OFF level	0 V	2 V	Operating current at ON (at input voltage 24 V)		-	4.5 mA	Allowable leak current at OFF		-	0.5 mA							
Item		Min	Max																									
Operating voltage (SOURCE)	ON level	22 V	27 V																									
	OFF level	0 V	2 V																									
Operating current at ON (at input voltage 24 V)		-	4.5 mA																									
Allowable leak current at OFF		-	0.5 mA																									
[PLC]	Programmable controller signal power source	<p>(1) The terminal is used for connecting the output signal power source of the programmable controller (rated voltage DC +24 V (power supply voltage fluctuation range: DC +22 to +27 V) maximum 100 mA).</p> <p>(2) The terminal can also be used for the power source for the load connected to the transistor outputs. For details, refer to the page on "Transistor outputs".</p>																										

Table 2.2-30 Functional Description of Control Circuit Terminals (continued)

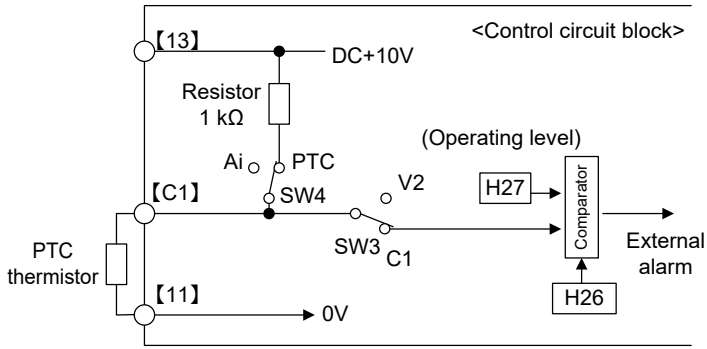
Classification	Terminal symbol	Terminal name	Functional description
	[CM]	Digital common	<p>This terminal is the common terminal for digital input signals.</p> <p>This terminal is insulated from terminals [11] and [CMY].</p>
Digital Input	<p>Tip ■ When turning terminals [FWD], [REV], [X1] to [X5] ON and OFF using relay contacts</p> <p>Figure 2.2-16 shows an example of the circuit configuration using relay contact. Circuit (a) in Figure 2.2-16 shows the circuit configuration when the switch (SW1) is on the sink side and circuit (b) shows the circuit configuration when the switch is on the source side.</p> <p>Caution: Use a relay which will not have contact failures (high contact reliability).</p> <div style="display: flex; justify-content: space-around;">   </div> <p style="text-align: center;">(a) Switch on sink side (b) Switch on source side</p> <p style="text-align: center;">Figure 2.2-16 Circuit Configuration Example Using Relay Contact</p>		
	<p>Tip ■ When turning terminals [FWD], [REV], [X1] to [X5] ON and OFF using the programmable controller</p> <p>Figure 2.2-17 shows an example of the circuit configuration using programmable controller. Circuit (a) in Figure 2.2-17 shows the circuit configuration when the switch (SW1) is on the sink side and circuit (b) shows the circuit configuration when the switch is on the source side.</p> <p>In circuit (a), terminals [FWD], [REV], [X1] to [X5] can be turned ON/OFF by shorting/opening the open collector transistor output of the programmable controller using the external power supply. Follow the instructions below when using this type of circuit.</p> <ul style="list-style-type: none"> • Connect the + side of the external power supply which is insulated from the programmable controller power supply to terminal [PLC]. • Do not connect the inverter's [CM] terminal and the common terminal of the programmable controller. <div style="display: flex; justify-content: space-around;">   </div> <p style="text-align: center;">(a) Switch on the sink side (b) Switch on the source side</p> <p style="text-align: center;">Figure 2.2-17 Circuit Configuration Example Using Programmable Controller</p> <p>Refer to "2.2.8 Operating slide switches" for more information on the switches.</p>		

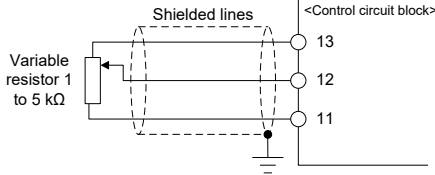
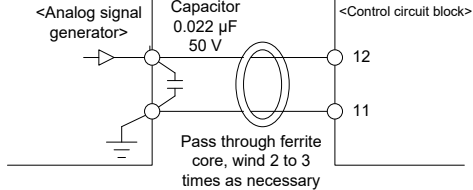
Table 2.2-30 Functional Description of Control Circuit Terminals (continued)

Classification	Terminal symbol	Terminal name	Functional description	
Analog output/pulse output	[FM]	Analog monitor FMV function FMI function	<p>This terminal outputs analog direct current voltage DC0 to 10 V or analog direct current DC4 to 20 mA / DC0 to 20mA monitor signal. The output form (FMV/FMI) can be switched using SW5 on the printed circuit board and function code F29. Refer to "Table 2.2-31 Functional Description of Slide switches".</p> <p>The signal content can be chosen in the function code F31 data setting among the following items.</p> <ul style="list-style-type: none"> • Output frequency 1 (before slip compensation) • Output frequency 2 (after slip compensation) • Output current • Output voltage • Output torque • Load factor • Input power • PID feedback value • Actual speed/estimated speed • DC link bus voltage • Universal AO • Motor output • Calibration (+) • PID command (SV) • PID output (MV) • Position error in master-follower operation • Inverter heat sink temperature • PG feedback value • Customizable logic output signal 1 to 10 <p>* Allowable impedance for connection: Min 5 kΩ (at DC to 10 V output) (up to 2 analog volt meters (DC0 to 10 V, input impedance 10 kΩ) can be connected.)</p> <p>* Allowable impedance for connection: Max 500 Ω (at DC4 to 20 mA/DC0 to 20 mA)</p> <p>* Gain adjustable range: 0 to 300%</p>	
		Pulse monitor FMP function	<p>The terminal outputs pulse signal. Signal content can be chosen same as for the FMV function by function code F31 setting. The output form (FMP) can be switched using SW5 on the printed circuit board and function code F29. Refer to "Table 2.2-31 Functional Description of Slide switches".</p> <p>* Allowable impedance for connection: Min. 5 kΩ (at DC to 10 V output) (up to 2 analog volt meters (DC0 to 10 V, input impedance 10 kΩ) can be connected.)</p> <p>* Pulse duty: Approximately 50%, pulse rate: 25 to 32000 p/s (at full scale)</p>	
			<p>• Pulse output waveform</p> 	<p>• FMP output circuit</p> 
	[FM2]	Analog monitor FMV2 function FMI2 function	<p>This terminal outputs analog direct current voltage DC0 to 10 V or analog direct current DC4 to 20 mA (DC0 to 20mA) monitor signal. The output form (FMV2/FMI2) can be switched using SW7 on the printed circuit board and function code F32. Refer to "Table 2.2-13 Functional Description of Slide switches".</p> <p>The signal content can be chosen in the function code F35 data setting among the same items with [FM] (F31).</p> <p>* This terminal is used on the models with the destination codes -GB/-C.</p> <p>* Allowable impedance for connection: Min 5 kΩ (at DC to 10 V output) (up to 2 analog volt meters (DC0 to 10 V, input impedance 10 kΩ) can be connected.)</p> <p>* Allowable impedance for connection: Max 500 Ω (at DC4 to 20 mA/DC0 to 20 mA)</p> <p>* Gain adjustable range: 0 to 300%</p>	
[11]	Analog output common terminal	This terminal is the common terminal for analog input and analog/pulse output signals. The terminal is insulated from terminals [CM] and [CMY]. Do not use [CM] and [CMY] as common terminals for [FM], [FM2].		

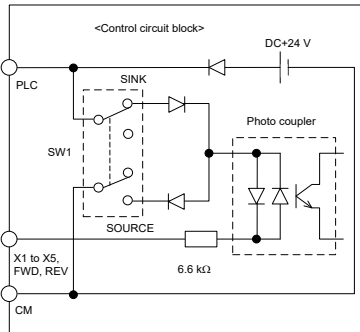
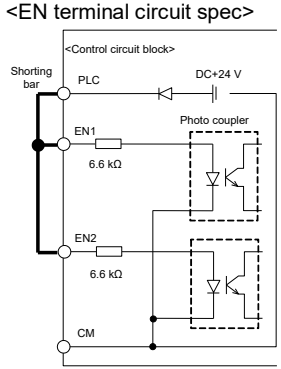
Table 2.2-30 Functional Description of Control Circuit Terminals (continued)

Classification	Terminal symbol	Terminal name	Functional description														
Transistor outputs	[Y1]	Transistor output 1	<p>(1) Various signals (running signal, frequency reached signal, overload forecast signal, etc) set up by function code E20, E21 can be output. For details, refer to Chapter 5 "FUNCTION CODES". (2) The operating mode of the transistor output terminals [Y1], [Y2] can be switched to "ON (active ON) at signal output" or "OFF (active OFF) at signal output".</p> <p><Transistor output circuit specification></p>  <table border="1" data-bbox="986 593 1361 790"> <thead> <tr> <th colspan="2">Item</th> <th>Maximum</th> </tr> </thead> <tbody> <tr> <td rowspan="2">Operating voltage</td> <td>ON level</td> <td>3 V</td> </tr> <tr> <td>OFF level</td> <td>27 V</td> </tr> <tr> <td colspan="2">Max load current at ON</td> <td>50 mA</td> </tr> <tr> <td colspan="2">Leak current at OFF</td> <td>0.1 mA</td> </tr> </tbody> </table> <p>Figure 2.2-18 Transistor Output Circuit</p> <p>Note</p> <ul style="list-style-type: none"> Connect a surge absorbing diode between the terminals the excitation coil when connecting control relays. When a power source is needed for the circuit to be connected, terminal PLC can be used as a power source terminal. Rated voltage: DC+24 V (power supply voltage fluctuation range: DC+22 to +27 V), maximum 50 mA). In this case, terminal [CMY] must be shorted to terminal [CM]. 	Item		Maximum	Operating voltage	ON level	3 V	OFF level	27 V	Max load current at ON		50 mA	Leak current at OFF		0.1 mA
	Item			Maximum													
	Operating voltage	ON level	3 V														
OFF level		27 V															
Max load current at ON		50 mA															
Leak current at OFF		0.1 mA															
[Y2]	Transistor output 2																
[CMY]	Transistor output common	This terminal is the common terminal for transistor output signals. This terminal is insulated from terminals [CM] and [11].															
<p>Tip ■ When connecting the programmable controller to terminals [Y1], [Y2].</p> <p>The circuit configuration example for connecting the inverter transistor output to the programmable controller is shown in Figure 2.2-19. Circuit (a) in Figure 2.2-19 shows the programmable controller input circuit as sink input and circuit (b) shows as the source input case.</p>  <p>(a) Connection diagram for sink input type programmable controller</p> <p>(b) Connection diagram for source input type programmable controller</p> <p>Figure 2.2-19 Example of Connection Circuit Configuration with Programmable Controller</p>																	
Contact output	[30A/B/C]	Integrated alarm output	<p>(1) When the inverter stops with an alarm, output is generated on the relay contact (1C). Contact rating: AC250 V 0.3 A $\cos\phi = 0.3$, DC48 V 0.5 A</p> <p>(2) Terminals can be switched to "Terminals [30A to 30C] shorted (excitation: active ON) at ON signal output" or "Terminals [30A to 30C] open (non-excitation: active OFF) at ON signal output"</p>														

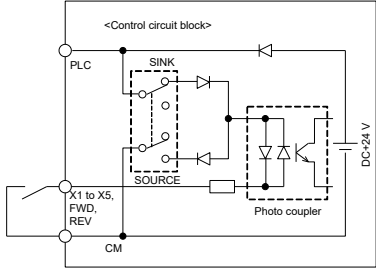
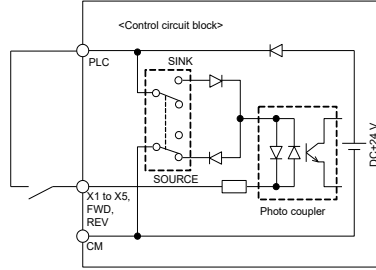
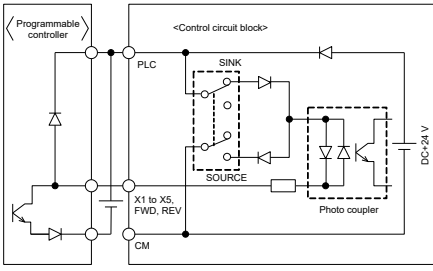
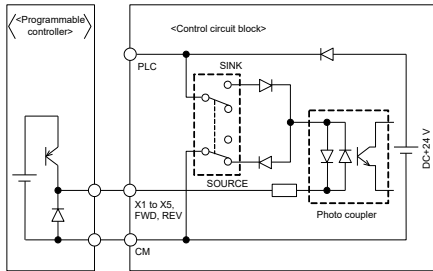
Table 2.2-30 Functional Description of Control Circuit Terminals (continued)

Classification	Terminal symbol	Terminal name	Functional description
Communication	RJ-45 connector for keypad connection	RJ-45 connector for keypad connection RS-485 communication port 1	<p>(1) Used to connect the keypad. The power to the keypad will be supplied from the inverter through this connector.</p> <p>(2) Also can be used to connect a computer, programmable controller, etc by RS-485 communication, after removing the keypad. (On terminating resistor, refer to “2.2.8 Operating slide switches”).</p>  <p style="text-align: center;">Figure 2.2-20 RJ-45 Connector Pin-layout</p> <ul style="list-style-type: none"> • Pins 1, 2, 7, and 8 are assigned as power supply source for the keypad. When connecting this RJ-45 connector to other devices, do not use these pins.
	RJ-45 connector for RS-485 /CANopen communication	RS-485 communication port 2 CANopen communication port	<p>(1) Can be used to connect a computer, programmable controller, etc by RS-485 communication. (On terminating resistor, refer to “2.2.8 Operating slide switches”).</p> <p>(2) Also can be used to connect a computer, programmable controller, etc by CANopen communication. (On terminating resistor, refer to “2.2.8 Operating slide switches”).</p>  <p style="text-align: center;">Figure 2.2-21 RJ-45 Connector Pin-layout</p> <ul style="list-style-type: none"> * This terminal is used on the models with the destination codes -RJ * SW6 is shared between RS-485 communications and CAN bus communications. If both communications are used at the same time and the necessity of the terminating resistor for each communication network is different (for example in the CAN bus is located at either end of the network, but in the RS-485 network is located in the middle), turn SW6 “OFF” and use an external terminating resistor where needed.

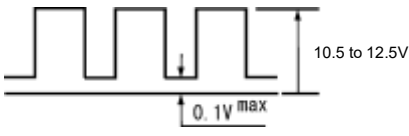
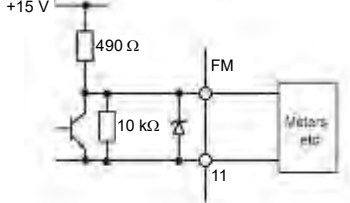
■ Wiring for control circuit terminals

For VXT-361A-4 to VXT-590A-4

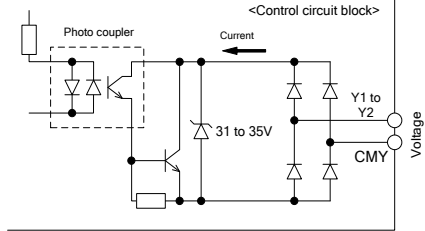
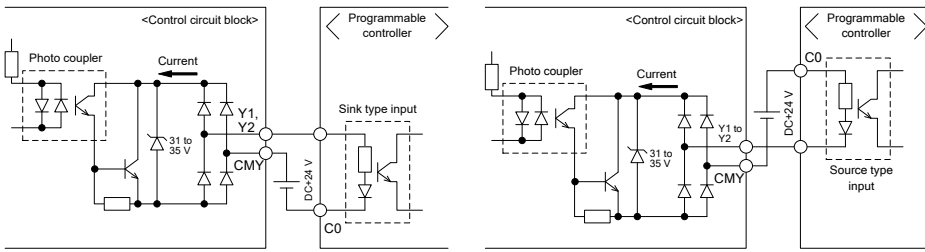
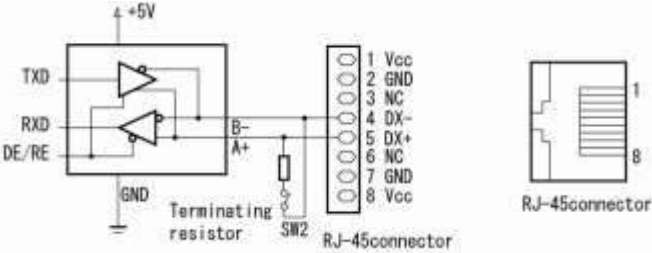
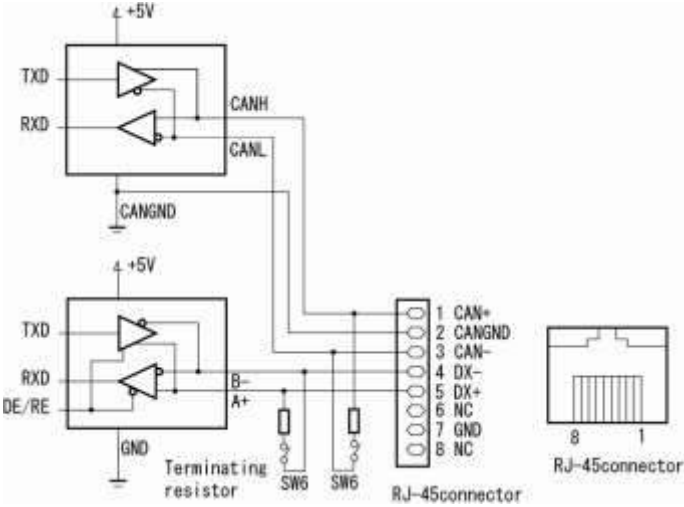
- (1) As shown in Figure 2.2-22, route the control circuit wires along the left side panel to the outside of the inverter.
- (2) Secure those wires to the wiring support, using a cable tie with 3.8 mm (0.15inch) or less in width and 1.5 mm or less in thickness.

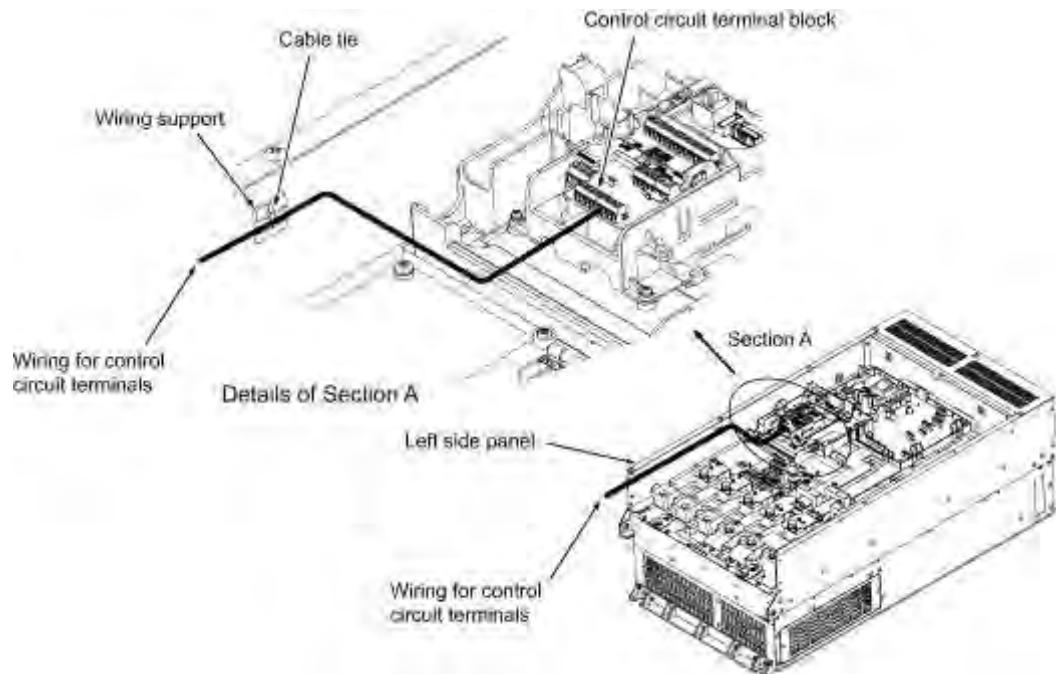

Figure 2.2-22 Wiring Route and Fixing Position for the Control Circuit Wires



- Route the wiring of the control circuit terminals as far as possible from the wiring of the main circuit. Otherwise electric noise may cause malfunctions.
- Fix the control circuit wires with a cable tie inside the inverter to keep them away from the live parts of the main circuit (such as the terminal block of the main circuit).

2.2.7 Switching connector (types VXT-203A-4 or above)

■ **Position of each connector**

The individual switching connectors are located on the power supply printed circuit board as shown in Figure 2.2-23.

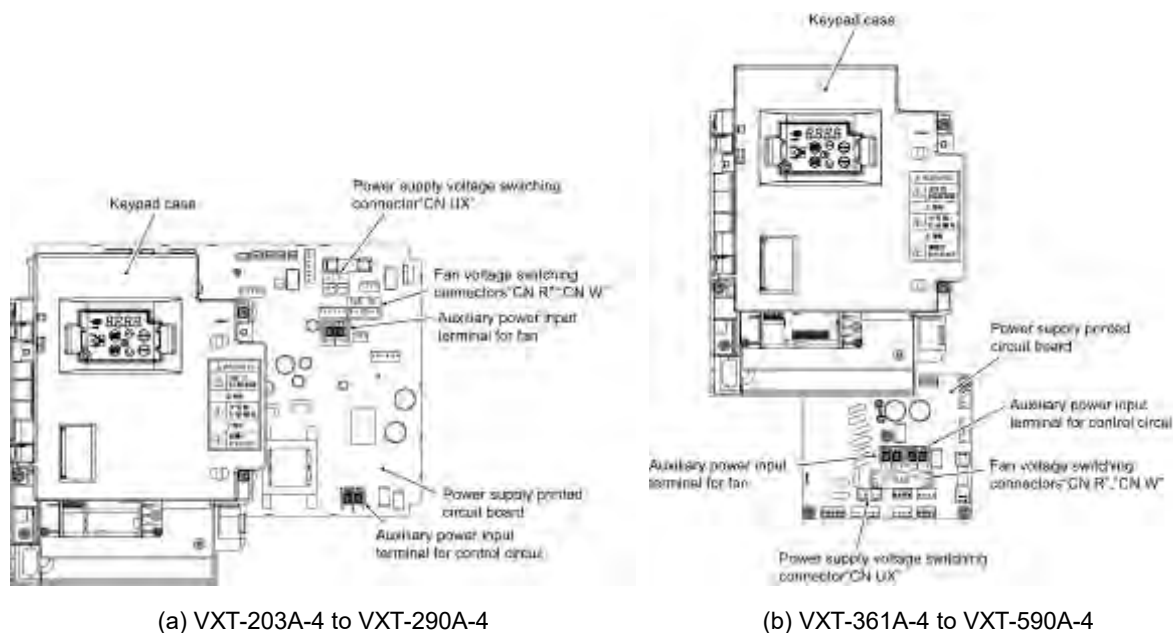
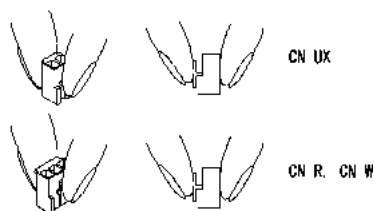

Figure 2.2-23 Switching Connector Positions



Note When removing the individual connectors, pinch the upper portion of the connector with the fingers, unlock the fastener, and pull. When inserting the connector, push in until the fastener lock engages with the receiving end with a click.

Figure 2.2-24 Attachment and Removal of the Switching Connector

■ **Power supply switching connector “CN UX” (types VXT-203A-4 or above)**

This power supply switching connector “CN UX” is equipped on VXT-203A-4 or above. Set the connector CN UX to U1 side (default) or U2 side depending on the power supply voltage specifications to be connected to the main power supply input terminals (L1/R, L2/S, L3/T) and/or the auxiliary power input terminals for the fan (R1, T1), according to the table below.

For details on the switching procedure, refer to “Figure 2.2-23 Switching Connector Positions” and “Figure 2.2-24 Attachment and Removal of the Switching Connector”.

(a) VXT-203A-4 to VXT-290A-4

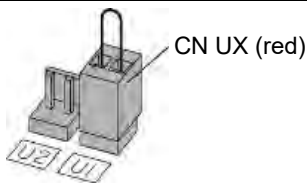
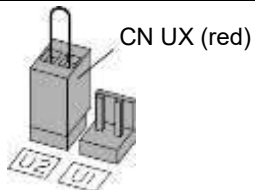
Setting		
Applicable voltage	398 to 440 V/ 50 Hz, 430 to 480 V/ 60 Hz (Factory default Model: -GA/-GB)	380 to 398V/ 50 Hz, 380 to 430 V/ 60 Hz (Factory default Model: -C)

(b) VXT-361A-4 to VXT-590A-4

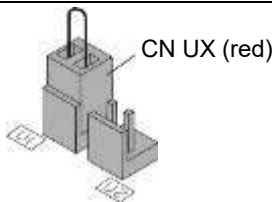
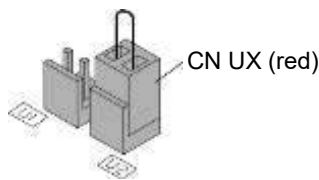
Setting		
Applicable voltage	398 to 440 V/ 50 Hz, 430 to 480 V/ 60 Hz (Factory default Model: -GA/-GB)	380 to 398V/ 50 Hz, 380 to 430 V/ 60 Hz (Factory default Model: -C)

■ Fan power source switching connector “CN R”, “CN W” (types VXT-203A-4 or above)

Jaguar VXT- supports direct current power supply input with PWM converters in the standard specification. However, VXT-203A-4 or above contains parts which are driven by AC power supply such as the AC fan, so AC power must also be supplied. When using DC power for the inverter, move connector “CN R” to **[NC]** side, move connector “CN W” to **[FAN]** side, and connect an AC power source to the auxiliary power input terminals for the fan (R1, T1).

For details on the switching procedure, refer to “Figure 2.2-23 Switching Connector Positions” and “Figure 2.2-24 Attachment and Removal of the Switching Connector”.

(a) VXT-203A-4 to VXT-290A-4

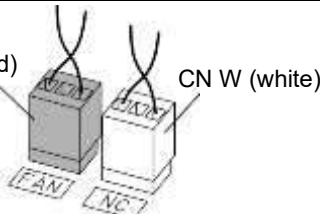
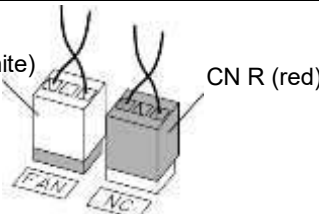
Setting		
Purpose	In the case terminals R1 and T1 are NOT used (Factory default)	In the case terminals R1 and T1 are used <ul style="list-style-type: none"> • DC bus input type • Combination with PWM converter

(b) VXT-361A-4 to VXT-590A-4

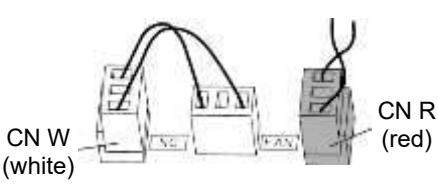
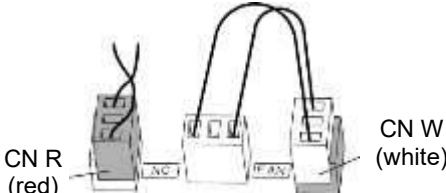
Setting		
Purpose	In the case terminals R1 and T1 are NOT used (Factory default)	In the case terminals R1 and T1 are used <ul style="list-style-type: none"> • DC bus input type • Combination with PWM converter

Note The fan power source switching connector “CN R” is on **[FAN]** and “CN W” is on **[NC]** when shipped from the factory. When direct current power supply input is not used, do not modify this setting. Mistakes in the fan power source switching connector setting may prevent the cooling fan from operating, and alarms such as cooling fin overheat *Oh1* and charging circuit error *pbf* may be generated.

2.2.8 Operating slide switches

⚠ WARNING ⚠

Operation of the slide switches should be conducted **after more than 5 minutes has elapsed** since power is shut off **for types VXT-115A-2 / VXT-72A-4 or below** and **after more than 10 minutes has elapsed for types VXT-85A-4 or above**. Confirm that the LED monitor and the charge lamp are turned off, and that the direct current intermediate circuit voltage between the main circuit terminals P(+)-N(-) is below the safe voltage (below DC+25 V) with a tester before operating the switches.

Risk of electric shock exists.

The I/O terminal specification can be changed, such as switching the analog output form, by operating the slide switches on the printed circuit board (Figure 2.2-25 Slide Switch Locations on the Control Printed Circuit Board). To operate the slide switches, remove the front cover and make the control printed circuit board visible. (For types VXT-85A-4 or above, also open the keypad case).

Refer to “2.2.2 Removal and attachment of the front cover/ terminal cover and wiring guide” to remove the front cover and to open/close the keypad case.

The switch locations on the control printed circuit board are shown in Figure 2.2-25 below.

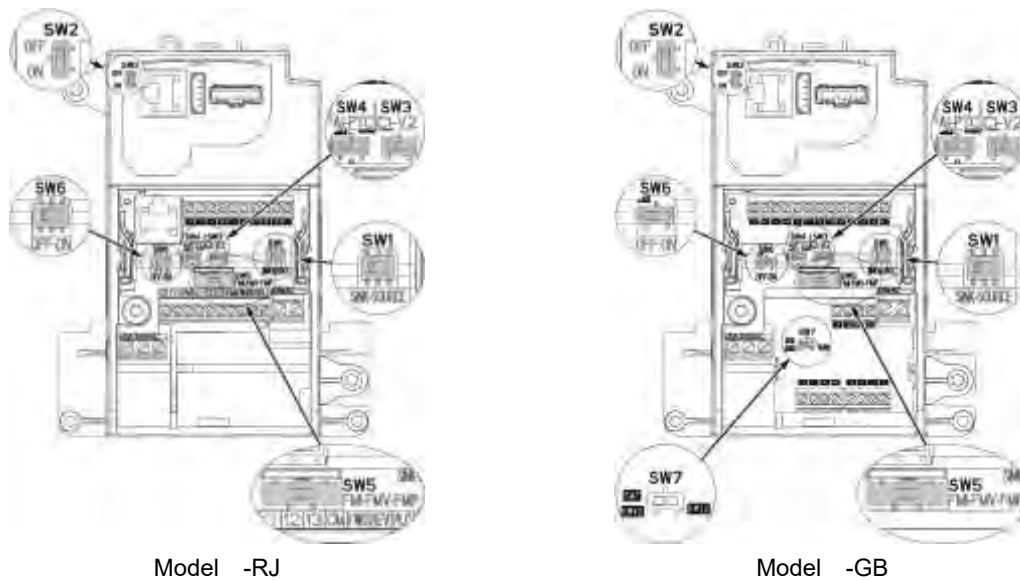

Figure 2.2-25 Slide Switch Locations on the Control Printed Circuit Board.

	SW1	SW2	SW3	SW4	SW5	SW6	SW7
Options	 SINK ← SOURCE →	 OFF ↑ ON ↓	 C1 ← V2 →	 AI ← PTC →	 FMV ← FMP →	 OFF ← ON →	 FMV2 ← FM12 →
Factory default	 SOURCE →	 OFF ↑	 C1 ←	 AI ←	 FMV ←	 OFF ←	 FMV2 ←

Use pointed devices (such as tweezers) to operate the switches. Avoid touching other electronic parts when moving the switches. The switch will be at open state when the slider is in the middle, so make sure to push the slider to the ends.

Functional description of the slide switches is explained in Table 2.2-31 Functional Description of Slide switches.

Table 2.2-31 Functional Description of Slide switches

Switch symbol	Functional description																				
SW1	<Switch to change sink/source setting of digital input terminals> <ul style="list-style-type: none"> This switch determines the type of input (sink or source) to use for digital input terminals [X1] to [X5], FWD, and REV. 																				
SW2	<Switch to change the RS-485 communication port 1 terminating resistor (RS-485 communication port (on the control PCB))> <ul style="list-style-type: none"> Move the switch to the ON side when RS-485 communication is used and the inverter is located at either end of the communication network. 																				
SW3 SW4	<Switch to change terminal [C1] input setting to current/voltage/PTC thermistor> This switch changes the input type for terminal [C1]. <table border="1" data-bbox="375 555 1388 719"> <thead> <tr> <th>Input type</th> <th>SW3</th> <th>SW4</th> <th>E59</th> <th>H26</th> </tr> </thead> <tbody> <tr> <td>Current input (factory default)</td> <td>C1 side</td> <td>AI side</td> <td>0</td> <td>0</td> </tr> <tr> <td>Voltage input</td> <td>V2 side</td> <td>AI side</td> <td>1</td> <td>0</td> </tr> <tr> <td>PTC thermistor input</td> <td>C1 side</td> <td>PTC side</td> <td>0</td> <td>1</td> </tr> </tbody> </table>	Input type	SW3	SW4	E59	H26	Current input (factory default)	C1 side	AI side	0	0	Voltage input	V2 side	AI side	1	0	PTC thermistor input	C1 side	PTC side	0	1
Input type	SW3	SW4	E59	H26																	
Current input (factory default)	C1 side	AI side	0	0																	
Voltage input	V2 side	AI side	1	0																	
PTC thermistor input	C1 side	PTC side	0	1																	
SW5	<Switch to change terminal [FM] output setting to current/voltage/pulse> This switch changes the output type for terminal [FM]. When operating this switch, also change function code F29. <table border="1" data-bbox="375 824 1388 987"> <thead> <tr> <th>Output type</th> <th>SW5</th> <th>F29</th> </tr> </thead> <tbody> <tr> <td>Current output</td> <td>FMI side</td> <td>1 or 2</td> </tr> <tr> <td>Voltage output (factory default)</td> <td>FMV side</td> <td>0</td> </tr> <tr> <td>Pulse output</td> <td>FMP side</td> <td>3</td> </tr> </tbody> </table>	Output type	SW5	F29	Current output	FMI side	1 or 2	Voltage output (factory default)	FMV side	0	Pulse output	FMP side	3								
Output type	SW5	F29																			
Current output	FMI side	1 or 2																			
Voltage output (factory default)	FMV side	0																			
Pulse output	FMP side	3																			
SW6	<Switch to change the RS-485 communication port 2 terminating resistor (RS-485 communication port (on the terminal board))> <ul style="list-style-type: none"> Used for the RS-485/CANopen communication. Move the switch to the ON position when the inverter is located at either end of the communication network. 																				
SW7	<Switch to change terminal [FM2] output setting to voltage/current> The terminal is used only on the model with the destination code -C. This switch changes the output type for terminal [FM2]. When operating this switch, also change function code F32. <table border="1" data-bbox="375 1249 1388 1373"> <thead> <tr> <th>Output type</th> <th>SW7</th> <th>F32</th> </tr> </thead> <tbody> <tr> <td>Voltage output</td> <td>FMV2 side</td> <td>0</td> </tr> <tr> <td>Current output</td> <td>FMI2 side</td> <td>1 or 2</td> </tr> </tbody> </table>	Output type	SW7	F32	Voltage output	FMV2 side	0	Current output	FMI2 side	1 or 2											
Output type	SW7	F32																			
Voltage output	FMV2 side	0																			
Current output	FMI2 side	1 or 2																			



Exercise caution as expected operation may not result if the setting above is not conducted accurately.

2.3 Attachment and Connection of Keypad

2.3.1 Parts required for connection

The following parts are necessary when attaching the keypad to locations other than the inverter main body.

Part name	Type	Remarks
Keypad extension cable (note 1)	Jaglead1M /2M /3M	Three lengths available (1Mtr, 2Mtr & 3Mtr)
Keypad fixing screws	M3×□ (note 2)	2 screws required (prepared by user)

(Note 1) When using commercially available LAN cable, use straight cables (below 20 meters)

(Note 2) When attaching to the cabinet, use a fixing screw of appropriate length to the cabinet thickness.

2.3.2 Attachment procedure

The keypad can be attached in the following forms.

- Attach to the inverter main body (refer to Figure 2.3-1 (a), (b), (c))
- Attach to the cabinet (refer to Figure 2.3-2)
- Operate the panel remotely, on the hand (refer to Figure 2.3-3)

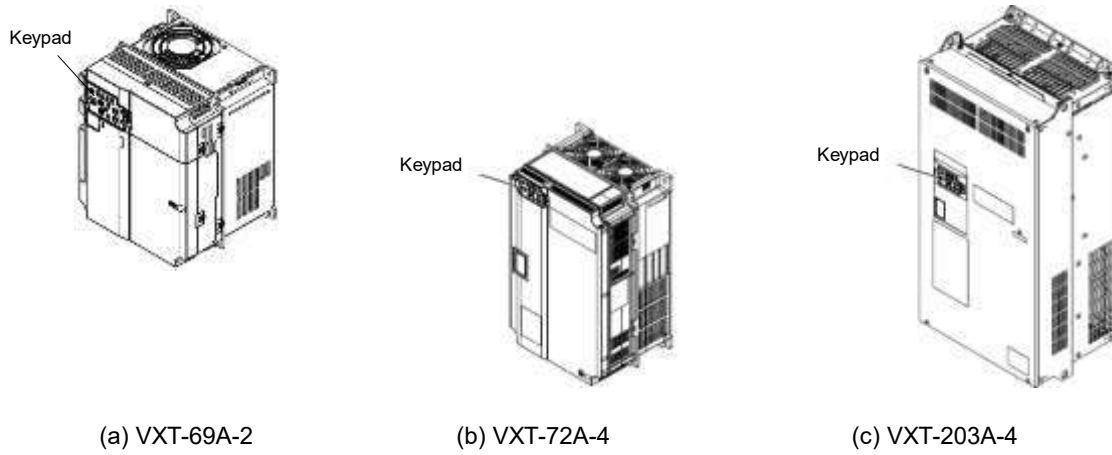

Figure 2.3-1 Attaching the Keypad to the Inverter Main Body

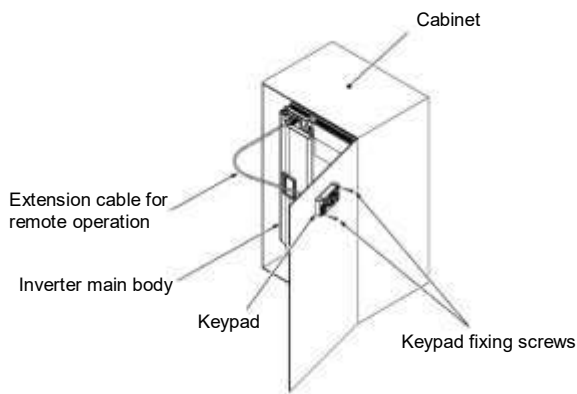

Figure 2.3-2 Attaching the Keypad on the Cabinet

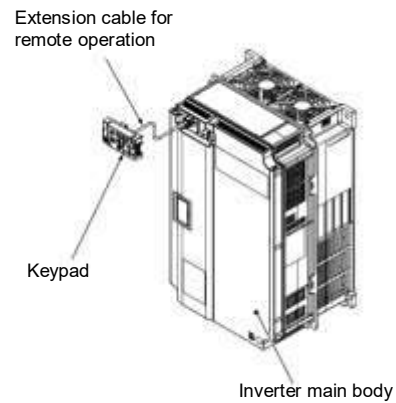

Figure 2.3-3 Operating the Keypad Remotely, on the Hand

■ Attachment to the cabinet

- (1) Squeeze the hooks at the arrows and pull as shown in Figure 2.3-4.

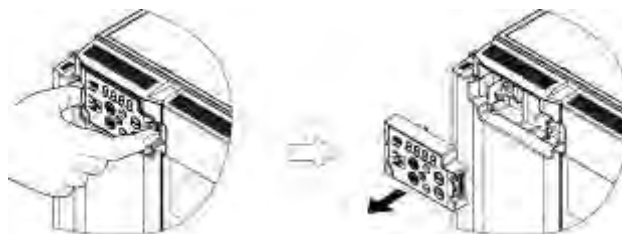

Figure 2.3-4 Removal of the Keypad

- (2) Attach the keypad rear cover to the keypad using the included keypad rear cover fixing screw.

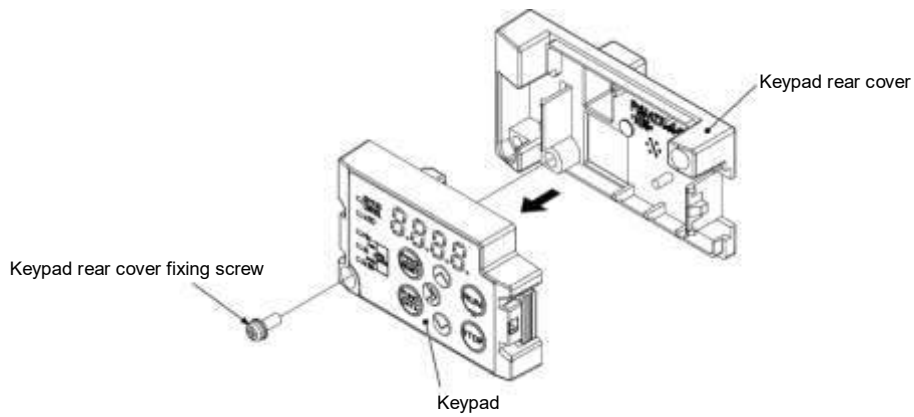

Figure 2.3-5 Attachment of the Keypad

- (3) Cut the cabinet to attach the keypad, as shown in Figure 2.3-6.

(Units: mm [inch])

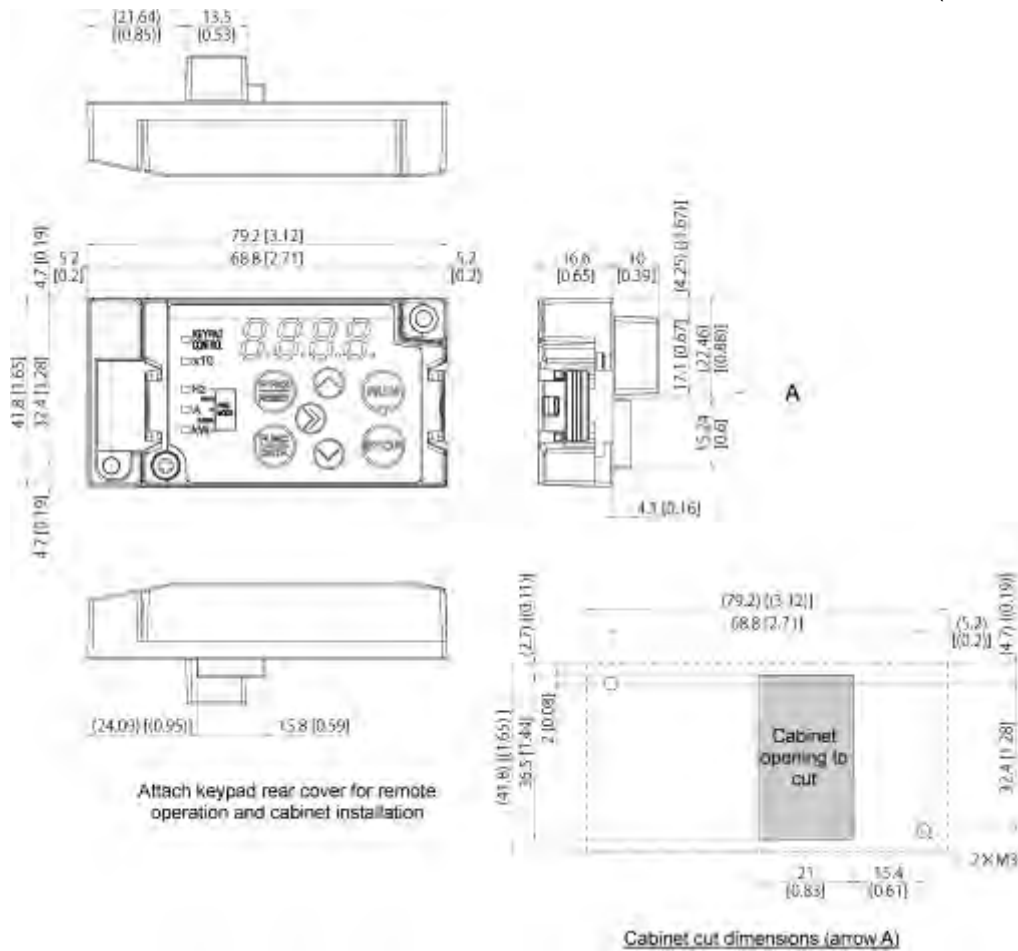

Figure 2.3-6 Fixing Screw Positions and the Dimensions of the Cabinet to Cut

- (4) Fix the keypad to the cabinet using 2 keypad rear cover fixing screws. (Refer to Figure 2.3-7) (tightening torque: 0.7 N•m(6.2lb-in))

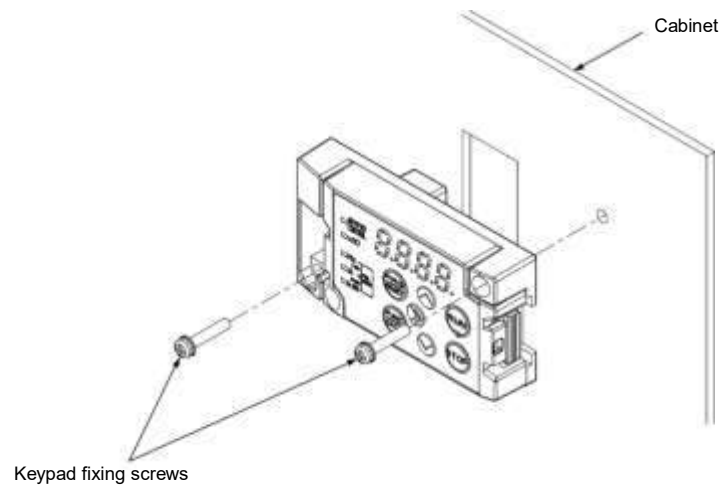

Figure 2.3-7 Attachment of the Keypad

- (5) Connect a commercially available LAN cable (straight) to the keypad RJ-45 connector and the inverter main body RJ-45 connector (modular jack). (Refer to Figure 2.3-8.)

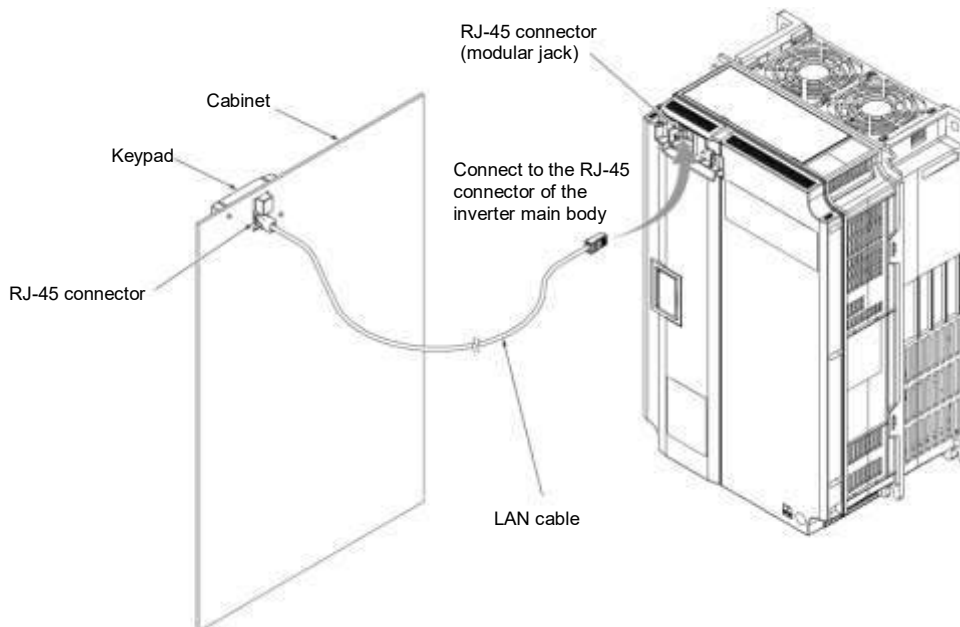

Figure 2.3-8 Connection a Commercially Available LAN Cable between the Keypad and the Inverter Main Body

⚠ CAUTION

- Do not connect the inverter to PC LAN ports, Ethernet hubs, or telephone lines. The inverter and the connected instrument may be damaged.

Risk of fire and risk of accidents exist.

■ Operating remotely, on the hand

Connect following the procedure (5) in “■ Attachment to the cabinet Attachment to the cabinet Attachment to the cabinet”.

2.4 RJ-45 Cover

The opening for the RS-485 communication cable connection (RJ-45 connector) is located below the keypad, as shown in Figure 2.4-1 and Figure 2.4-2. These models are special order.

■ Types VXT-69A-2 / VXT-44A-4 / VXT-11A-1 or below

To connect the RS-485 communication cable, open the RJ-45 cover as shown in Figure 2.4-1.

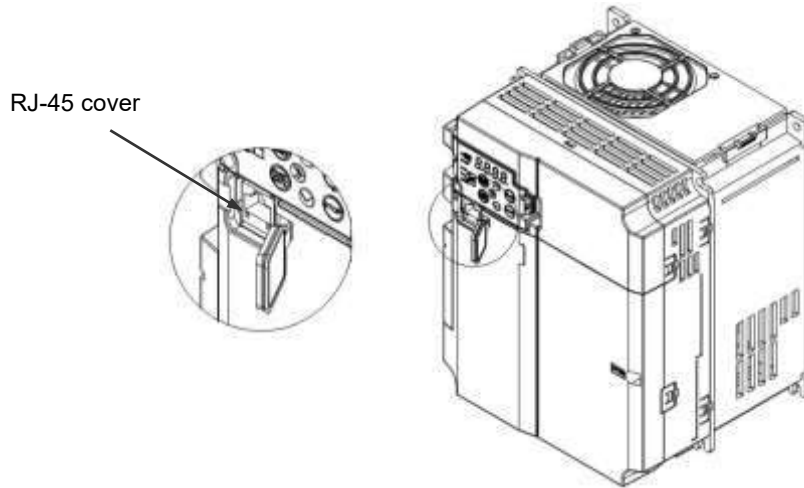

Figure 2.4-1 Connection of the RS-485 Communication Cable

■ Types VXT-88A-2 / VXT-59A-4 or above

To connect the RS-485 communication cable, open the RJ-45 cover until the “click” can be heard and connect the cable, as shown in Figure 2.4-2.

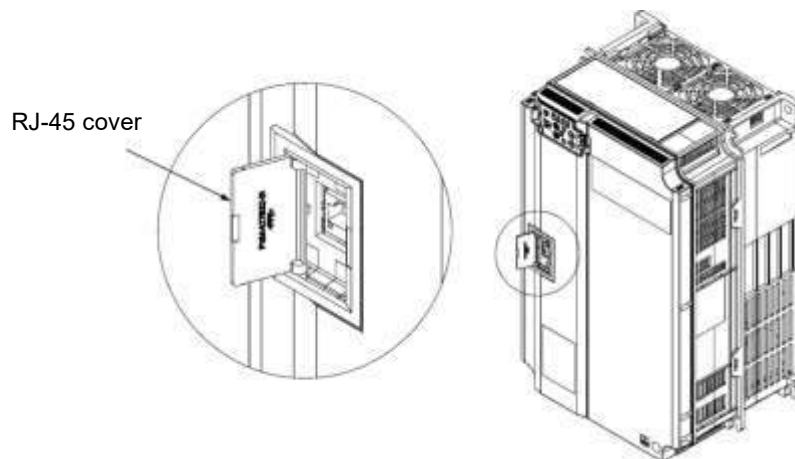

Figure 2.4-2 Connection of the RS-485 Communication Cable

Connect with the PC via the RS-485 converter using the RS-485 communication cable. The PC loader allows editing, confirmation, and management of the inverter function codes, and monitoring of operation data remotely. The operating status and alarms can also be monitored.

Chapter 3 OPERATION USING THE KEYPAD

Refer to the Jaguar VXT User’s Manual, Chapter 3 for details of the keypad.

3.1 Names and Functions of Keypad Components

The keypad allows you to run and stop the motor, display various data, configure function code data, and monitor I/O signal states, maintenance information and alarm information.

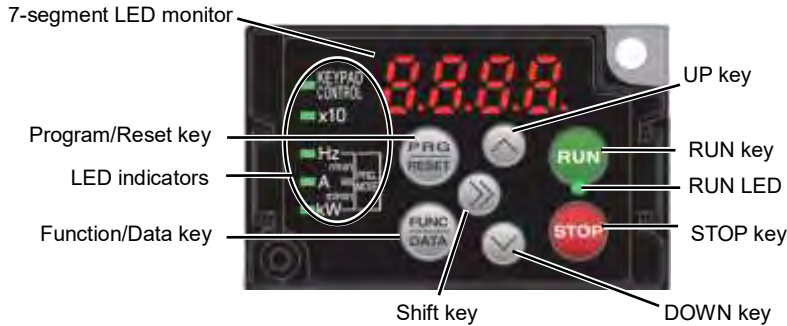

Table 3.1-1 Overview of Keypad Functions

Item	LED Monitor, Keys, and LED Indicators	Functions
LED Monitor		<p>Four-digit, 7-segment LED monitor which displays the followings according to the operation modes.</p> <ul style="list-style-type: none"> ■ In Running mode: Running status information (e.g., output frequency, current, and voltage) When a light alarm occurs, <i>l-a</i> is displayed. ■ In Programming mode: Menus, function codes and their data ■ In Alarm mode: Alarm code, which identifies the alarm factor that has activated the protective function.
Operation Keys		<p>Program/Reset key which switches the operation modes of the inverter.</p> <ul style="list-style-type: none"> ■ In Running mode: Pressing this key switches the inverter to Programming mode. ■ In Programming mode: Pressing this key switches the inverter to Running mode. ■ In Alarm mode: Pressing this key after removing the alarm factor resets the alarm and switches back to Running mode.
		<p>Function/Data key which switches the operations you want to do in each mode as follows:</p> <ul style="list-style-type: none"> ■ In Running mode: Pressing this key switches the information to be displayed concerning the status of the inverter (output frequency (Hz), output current (A), output voltage (V), etc.). When a light alarm is displayed, holding down this key resets the light alarm and switches back to Running mode. ■ In Programming mode: Pressing this key displays the function code or establishes the data entered with and keys. ■ In Alarm mode: Pressing this key displays the details of the problem indicated by the alarm code that has come up on the LED monitor.
		RUN key. Press this key to run the motor.
		STOP key. Press this key to stop the motor.
		UP and DOWN keys. Press these keys to select the setting items and change the function code data displayed on the LED monitor.
		Shift key. Press this key to shift the cursor to the right for entry of a numerical value.

3.1 Names and Functions of Keypad Components

Table 3.1-1 Overview of Keypad Functions (continued)

Item	LED Monitor, Keys, and LED Indicators	Functions
LED Indicators	RUN LED	Lights when running with a run command entered by the RUN key, by terminal command FWD or REV , or through the communications link.
	KEYPAD CONTROL LED	Lights when the inverter is ready to run with a run command entered by the RUN key (F02 = 0, 2, or 3). In Programming and Alarm modes, however, pressing the RUN key cannot run the inverter even if this indicator lights.
	Unit LEDs (3 LEDs)	These three LED indicators identify the unit of numeral displayed on the LED monitor in Running mode by combination of lit and unlit states of them. Unit: Hz, A, kW, r/min and m/min Refer to the Jaguar VXT User's Manual, "3.3.1 Monitoring the running status" for details. While the inverter is in Programming mode, <input checked="" type="checkbox"/> Hz the LEDs of Hz and kW light. <input type="checkbox"/> A <input checked="" type="checkbox"/> kW
	x10 LED	Lights when the data to display exceeds 9999. When this LED lights, the "displayed value x 10" is the actual value. Example: If data is "12,345," the LED monitor displays <i>1234</i> and the x10 LED lights, meaning that "1,234 × 10 = 12,340."

■ LED monitor

In Run mode, the LED monitor displays running status information (output frequency, current or voltage); in Programming mode, it displays menus, function codes and their data; and in Alarm mode, it displays an alarm code which identifies the alarm factor that has activated the protective function.

If one of LED 4 through LED1 is blinking, it means that the cursor is at this digit, allowing you to change it.

If the decimal point of LED1 is blinking, it means that the currently displayed data is a value of the PID command, not the frequency data usually displayed.



Figure 3.1-1 7-Segment LED Monitor

Table 3.1-2 Alphanumeric Characters on the LED Monitor

Character	7-segment	Character	7-segment	Character	7-segment	Character	7-segment
0	<i>0</i>	9	<i>9</i>	i	<i>i</i>	r	<i>r</i>
1	<i>1</i>	A	<i>a</i>	J	<i>j</i>	S	<i>s</i>
2	<i>2</i>	b	<i>Bb</i>	K	<i>k</i>	T	<i>T</i>
3	<i>3</i>	C	<i>Cc</i>	L	<i>l</i>	u	<i>U</i>
4	<i>4</i>	d	<i>d</i>	M	<i>m</i>	V	<i>v</i>
5	<i>5</i>	E	<i>e</i>	n	<i>n</i>	W	<i>w</i>
6	<i>6</i>	F	<i>f</i>	o	<i>o</i>	X	<i>x</i>
7	<i>7</i>	G	<i>g</i>	P	<i>p</i>	y	<i>y</i>
8	<i>8</i>	H	<i>h</i>	q	<i>q</i>	Z	<i>Z</i>
Special characters and symbols (numbers with decimal point, minus and underscore)							
0. - 9.	<i>*-)</i>	-	-	-	-		

3.2 Overview of Operation Modes

The Jaguar VXT features the following three operation modes.

Table 3.2-1 Operation Modes

Operation mode	Description
Running mode	When powered ON, the inverter automatically enters this mode. This mode allows you to specify the reference frequency, PID command value and etc., and run/stop the motor with the / keys. It is also possible to monitor the running status in real time. If a light alarm occurs, the <i>-a/</i> appears on the LED monitor.
Programming mode	This mode allows you to configure function code data and check a variety of information relating to the inverter status and maintenance.
Alarm mode	If an alarm condition arises, the inverter automatically enters Alarm mode in which you can view the corresponding alarm code* and its related information on the LED monitor. * Alarm code: Indicates the cause of the alarm condition. For details, first see “Table 6.1-1 Abnormal States Detectable (“Heavy Alarm” and “Light Alarm” Objects)” in Chapter 6 “6.1 Protective Function”, and then read the troubleshooting of each alarm.

Figure 3.2-1 shows the status transition of the inverter between these three operation modes.

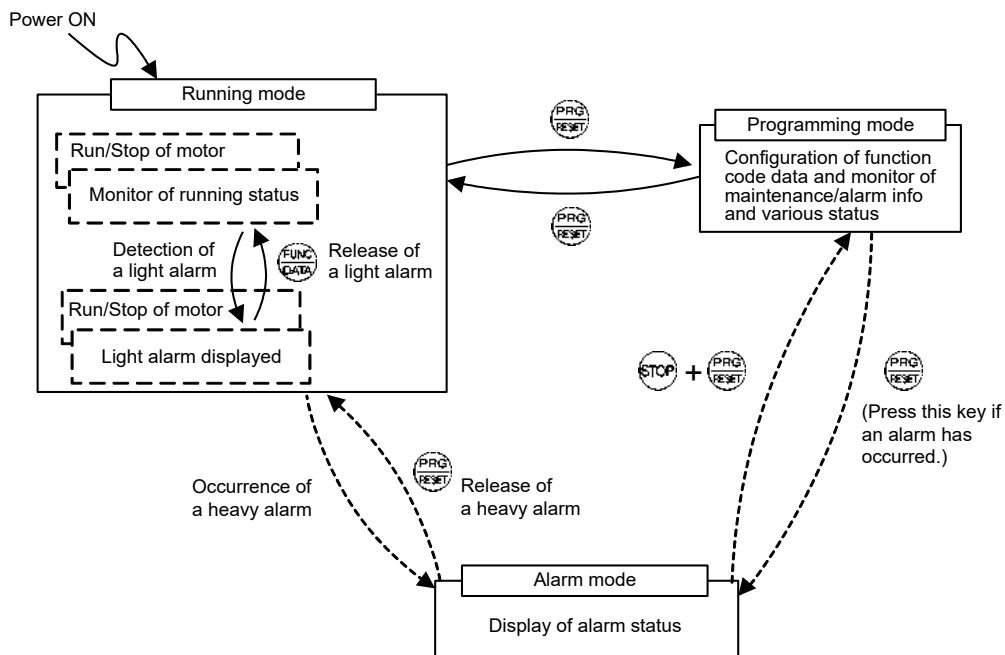

Figure 3.2-1 Status Transition between Operation Modes



Simultaneous keying

Simultaneous keying means pressing two keys at the same time. The simultaneous keying operation is expressed by a “+” letter between the keys throughout this manual.

For example, the expression “ + keys” stands for pressing the key with the key held down.

Figure 3.2-2 illustrates the transition of the LED monitor screen during Running mode, the transition between menu items in Programming mode, and the transition between alarm codes at different occurrences in Alarm mode.

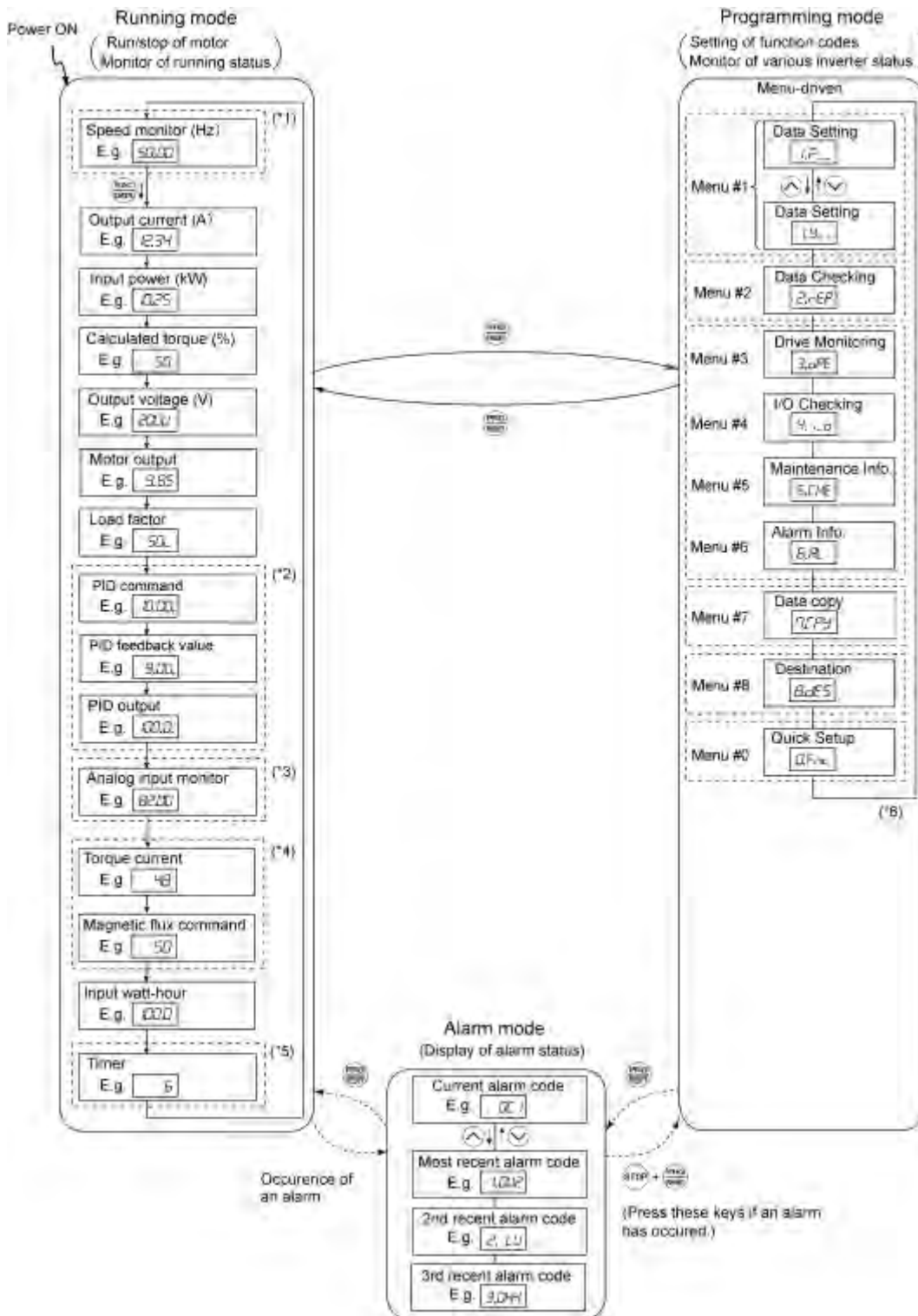

Figure 3.2-2 Transition between Basic Screens in Individual Operation Mode

- (*1) The speed monitor allows you to select the desired one from the speed monitor items by using function code E48.
- (*2) Applicable only when PID control is active (J01 = 1, 2 or 3).
- (*3) The analog input monitor can appear only when the analog input monitor function is assigned to one of the analog input terminals by one of function codes E61 to E63 (= 20).
- (*4) 0 appears under the V/f control.
- (*5) The Timer screen appears only when the timer operation is enabled with function code C21 (C21 = 1).
- (*6) Applicable only when the full-menu mode is selected (E52 = 2). When a remote keypad with USB is

equipped, 'c ρ ' is displayed.

Chapter 4 TEST RUN PROCEDURE

4.1 Test Run Procedure Flowchart

Make a test run of the motor using the flowchart given below.

This chapter describes the test run procedure with motor 1 dedicated function codes that are marked with an asterisk (*). For motor 2, replace those function codes with asterisk with motor 2 dedicated ones.

 For the function codes dedicated to motor 2, see Chapter 5 "FUNCTION CODES."

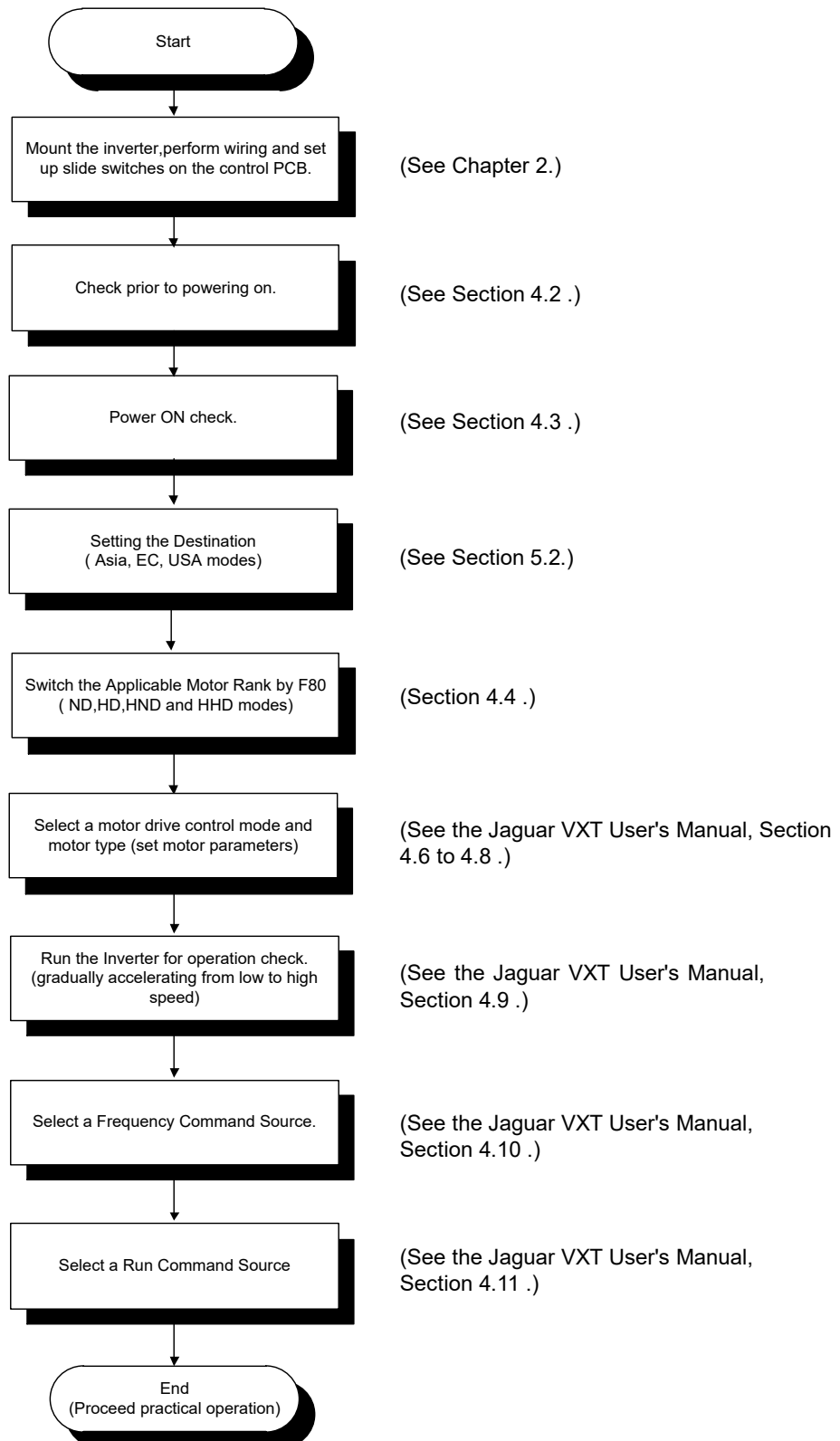

Figure 4.1-1 Test Run Procedure

4.2 Checking Prior to Powering On

Check the following before powering on the inverter.

- (1) Check that the wiring is correct.

Especially check the wiring to the inverter input terminals (L1/R, L2/S, L3/T or L1/L, L2/N) and output terminals (U, V, and W). Also check that the grounding wires are connected to the grounding terminals (G) correctly. See Figure 4.2-1.

⚠ WARNING

- Never connect power supply wires to the inverter output terminals U, V, and W. Doing so and turning the power ON breaks the inverter.
- Be sure to connect the grounding wires of the inverter and the motor to the ground electrodes.

Otherwise, an electric shock could occur.

- (2) Check the control circuit terminals and main circuit terminals for short circuits or ground faults.
- (3) Check for loose terminals, connectors and screws.
- (4) Check that the motor is separated from mechanical equipment.
- (5) Make sure that all switches of devices connected to the inverter are turned OFF. Powering on the inverter with any of those switches being ON may cause an unexpected motor operation.
- (6) Check that safety measures are taken against runaway of the equipment, e.g., a defence to prevent people from access to the equipment.
- (7) Check that a power factor correction DC reactor (DCR) is connected to the DC reactor terminals P1 and P(+). (ND-mode in case of inverters VXT-139A-4 or above, HD-/HND-mode in case of VXT-168A-4 or above, and HHD-mode in case of VXT-203A-4 or above must be used with a DCR. Be sure to connect the DCR to the inverter.)

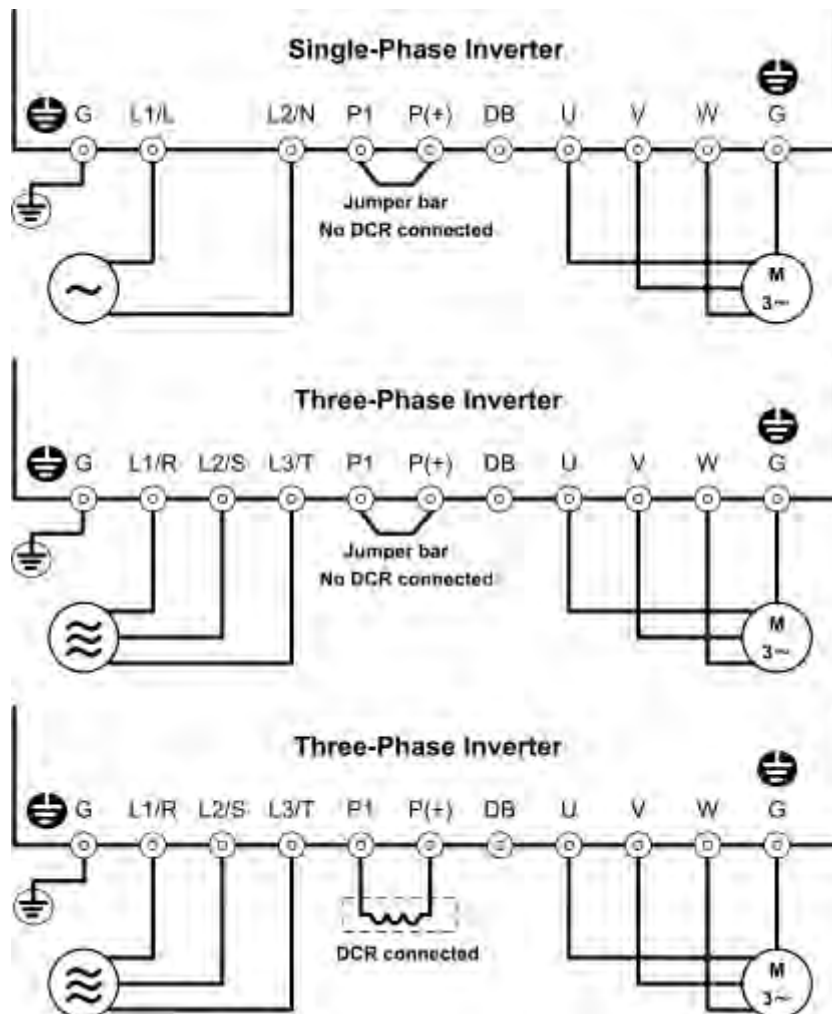

Figure 4.2-1 Connection of Main Circuit Terminals

4.3 Powering ON and Checking

⚠ WARNING

- Be sure to mount the front cover before turning the power ON. Do not remove the cover when the inverter power is ON.
- Do not operate switches with wet hands.

Otherwise, an electric shock could occur.

Turn the power ON and check the following points. The following is a case when no function code data is changed from the factory defaults.

- (1) Check that the LED monitor displays *des* (indicating that the destination is not set) that is blinking. See Figure 4.3-1.
- (2) Check that the inverter (built-in) cooling fans rotate.



Figure 4.3-1 Display of the LED Monitor after Power-on

4.4 Switching the Applicable Motor Rating (ND, HD, HND and HHD Modes)

Changing the data of function code F80 switches the applicable motor rank to match load conditions. In HD, HND or HHD mode, the inverter drives a motor whose capacity is one or two ranks lower than the inverter's one.

F80 data	Drive mode	Application	Applicable motor	Overload capability	Maximum frequency	Operating temperature	Application samples
4	ND mode	General load	Motor whose capacity is equal to the inverter.	120% for 1 min.	120 Hz	40°C (104°F)	Fan, pump, blower, compressor, etc.
3	HD mode	Heavy duty load	Motor whose capacity is one size lower than the inverter.	150% for 1 min.	500 Hz	40°C (104°F)	Wire drawing machine, winding machine, twisting machine, spinning frame, etc.
1	HND mode	General load	Motor whose capacity is one size lower than the inverter.	120% for 1 min.	500 Hz	50°C (122°F)	Fan, pump, blower, compressor, etc.
0	HHD mode	Heavy duty load	Motor whose capacity is two sizes lower than the inverter.	150% for 1 min. 200% for 0.5 s.	500 Hz	50°C (122°F)	Wire drawing machine, winding machine, twisting machine, spinning frame, hoist, machine tool, etc.

The HD-/HND-/HHD-mode inverter brings out the continuous rated current level which enables the inverter to drive a motor with one or two sizes lower capacity, but its overload capability (%) against the continuous current level or the operating temperature increases. For details, see Chapter 12 "SPECIFICATIONS."

Three-phase 400V series inverters are ND/HD/HND/HHD quadruple rated. However, the VXT-7A-4 and VXT-12A-4 are ND/HD/HHD triple rated.

Three-phase 200V series inverters are HND/HHD dual rated. However, the VXT-12A-2 and VXT-20A-2 are ND/HND dual rated.

Single-phase 200V series inverters are HHD single rating.

4.4 Switching the Applicable Motor Rating (ND, HD, HND and HHD Modes)

The inverter is subject to restrictions on the function code data setting range and internal processing as listed below.

Function codes	Name	ND mode	HD mode	HND mode	HHD mode	Remarks
F21*	DC braking (Braking level)	Setting range: 0 to 60%	Setting range: 0 to 80%		Setting range: 0 to 100%	
F26	Motor sound (Carrier frequency)	ND mode - 0.75 to 10 kHz (VXT-2A-4 to VXT-59A-4) - 0.75 to 10 kHz (VXT-12A-2 to VXT-20A-2) - 0.75 to 6 kHz (VXT-72A-4 or above) HD/HND mode - 0.75 to 16 kHz (VXT-4A-2 to VXT-88A-2) - 0.75 to 16 kHz (VXT-2A-4 to VXT-59A-4) - 0.75 to 10 kHz (VXT-7-4 to VXT-168A-4) - 0.75 to 10 kHz (VXT-115A-2) - 0.75 to 6 kHz (VXT-203A-4 or above) HHD mode - 0.75 to 16 kHz (VXT-4A-2 to VXT-115A-2) - 0.75 to 16 kHz (VXT-3A-1 to VXT-11A-1) - 0.75 to 16 kHz (VXT-2A-4 to VXT-168A-4) - 0.75 to 10 kHz (VXT-203A-4 or above)				In the ND/HD/HND mode, a value out of the range, if specified, automatically changes to the maximum value allowable in the ND/HD/HND mode.
F44	Current limiter (Level)	Initial value: 130%	Initial value: 160%	Initial value: 130%	Initial value: VXT-88A-2/ VXT-59A-4 or above : 160% VXT-69A-2/ VXT-44A-4 or below : 180%	Switching the drive mode with function code F80 automatically initializes the F44 data to the value specified at left.
F03*	Maximum frequency	Setting range: 25 to 500 Hz Upper limit: 120 Hz	Setting range: 25 to 500 Hz Upper limit: 500 Hz			In the ND mode, if the maximum frequency exceeds 120 Hz, the actual output frequency is internally limited to 120 Hz.
—	Current indication and output	Based on the rated current level for ND mode	Based on the rated current level for HD mode	Based on the rated current level for HND mode	Based on the rated current level for HHD mode	—

Switching between the drive modes does not automatically change the motor rated capacity (P02*) to the one suitable for the rank-changed motor, so configure the P02* data to match the applied motor rating as required.

Chapter 5 FUNCTION CODES

5.1 Function Codes Overview







Function codes are used for selecting various functions of VXT. Function codes comprise 3 digits or 4 digits of alphanumeric character. The first digit categorizes the group of function code alphabetically and the subsequent 2 or 3 digits identify each code within the group by number. Function code comprises 11 groups: Basic function (F code), Terminal function (E code), Control code (C code), Motor 1 parameter (P code), High-level function (H code), (H1 code), Motor 2 parameter (A code), Application function 1 (J code) (J1 code), Application function 2 (d code), Customizable logic (U code) (U1 code), Link function (y code), Keypad functions (K code), and Option function (o code). The function of each function code is determined according to the data to be set. The following descriptions are for supplementary explanation of function code table. Refer to instruction manual of each option to find the details of the option function (o code).

5.2 Function Codes Table

5.2.1 Supplementary note

■ Change, reflect, and save function code data during operation

Function codes are categorized into those which data change is enabled during operation of the inverter and those which such change is disabled. The meaning of the code in the “Change during operation” column of the function code table is described in the following table.

Code	Change during operation	Reflect and save data
Y*	Allowed	At the point when data is changed by  key, the changed data is immediately reflected on the operation of inverter. However, at this stage, the changed value is not saved to the inverter. In order to save it to the inverter, press  key. Without saving by  key and leaving the state of when the change was made by the  key, the data before the change is reflected on the operation of inverter.
Y	Allowed	Even if data is changed by the  key, the changed data will not be reflected on the operation of the inverter as is; by pressing the  key, the changed value is reflected on the operation of the inverter and is also saved to the inverter.
N	Not allowed	—

■ Copying data

Function code data can be copied collectively by using the optional keypad “OP-KP-USB” (program mode menu number 7 “Data copy”). By using this function, it is possible to read out all function code data and write the same data to a different inverter.

However, if the specification of inverter at the copy source and copy destination is not identical, some function codes may not be copied due to security reason. According to necessity, configure the settings individually for the function codes that are not copied. The behaviour of the function codes regarding data copy is indicated in the “data copy” column in the function code table in the next page and following.

Y: to be copied.

Y1: When inverter capacity is different, copying will not be performed.

Y2: When voltage group is different, copying will not be performed.

N: not to be copied.

■ Negative logic setting of data

Digital input terminal and transistor/contact output terminal can become a signal for which negative logic is specified by function code data setting. Negative logic is a function to reverse ON and OFF state of input or output, and switch Active ON (function enabled with ON: positive logic) and Active OFF (function enabled with OFF: negative logic). However, negative logic may not be enabled depending on the function of the signal.

Negative logic signal can be switched by setting the data with 1000 added to the function code data of the function to be set. For example, the following example shows when coast to a stop command "BX" is selected by function code E01.

Function code data	Action
7	"BX" is ON and coast to a stop (Active ON)
1007	"BX" is OFF and coast to a stop (Active OFF)

■ Drive control

The VXT runs under any of the following drive controls. Some function codes apply exclusively to the specific drive control, which is indicated by letters Y (Applicable) and N (Not applicable) in the "Drive control" column in the function code tables given on the following pages.

Abbreviation in "Drive control" column in function code tables	Control target (H18)	Drive control (F42)
V/f	Speed (Frequency for V/f and PG V/f)	0,2: V/f control 1: Dynamic torque vector control
PG V/f		3: V/f control with speed sensor 4: V/f control with speed sensor and auto torque boost
w/ PG		6: Vector control with speed sensor
Torque control	Torque	6: Vector control with speed sensor
PM	Speed	15: Vector control without speed sensor nor pole position sensor

For details about the drive control, refer to the description of the VXT User's Manual, F42 "Drive control selection 1."



The VXT is a general-purpose inverter whose operation is customized by frequency-basis function codes, like conventional inverters. Under the speed-basis drive control, however, the control target is a motor speed, not a frequency, so convert the frequency to the motor speed according to the following expression.

$$\text{Motor speed (r/min)} = 120 \times \text{Frequency (Hz)} \div \text{Number of poles}$$

5.2.2 Function codes table

The table of function codes to be used in VXT is shown below.
The related page shows the page of the user's manual.

■ **F codes: Fundamental Functions (Basic function)**

Code	Name	Data setting range	Change when running	Data copying	Factory Default	Drive control					Related page
						V/f	PG V/f	w/ PG	Torque control	PM	
F00	Data protection	0: No data protection, no digital setting protection 1: With data protection, no digital setting protection 2: No data protection, with digital setting protection 3: With data protection, with digital setting protection	Y	Y	0	Y	Y	Y	Y	Y	5-45
F01	Frequency setting 1	0: Keypad key operation (↔/↔key) 1: Analog voltage input (Terminal [12]) (from 0 to ±10 VDC) 2: Analog current input (Terminal [C1] (C1 function)) (4 to 20mA DC, 0 to 20mA DC) 3: Analog voltage input (Terminal [12]) + Analog current input (Terminal [C1] (C1 function)) 5: Analog voltage input (Terminal [C1] (V2 function)) (0 to 10 VDC) 7: UP/DOWN control 8: Keypad key operation (↔/↔key) (With balanceless bumpless) 10: Pattern operation 11: Digital input/output interface card (option) *5 12: Pulse train input	N	Y	0	Y	Y	Y	N	Y	5-46
F02	Operation method	0: Keypad operation (rotation direction input: terminal block) 1: External signal (digital input) 2: Keypad operation (forward rotation) 3: Keypad operation (Reverse rotation)	N	Y	2	Y	Y	Y	Y	Y	5-57
F03	Maximum output frequency 1	25.0 to 500.0 Hz	N	Y	50.0	Y	Y	Y	Y	Y	5-58
F04	Base frequency 1	25.0 to 500.0Hz	N	Y	50.0	Y	Y	Y	Y	Y	5-59
F05	Rated voltage at base frequency 1	0: AVR disable (output voltage proportional to power voltage) 80 to 240 V : AVR operation (200V class) 160 to 500V : AVR operation (400V class)	N	Y2	200V class 200V 400V class 400V	Y	Y	Y	Y	Y	
F06	Maximum output voltage 1	80 to 240V : AVR operation (200V class) 160 to 500V : AVR operation (400V class)	N	Y2	400V	Y	Y	N	Y	Y	
F07	Acceleration time1	0.00 to 6000 s	Y	Y	6.00	Y	Y	Y	N	Y	5-61
F08	Deceleration time1	* 0.00 is for acceleration and deceleration time cancel (when performing soft-start and stop externally)	Y	Y	or 20.0 *10	Y	Y	Y	N	Y	
F09	Torque boost 1	0.0 to 20.0% (% value against base frequency voltage 1)	Y	Y	*2	Y	Y	N	N	N	5-63
F10	Electronic thermal overload protection for motor 1 (Select motor characteristics)	1: Enable (For a general-purpose motor with self-cooling fan) 2: Enable (For an inverter-driven motor (FV) with separately powered cooling fan)	Y	Y	1	Y	Y	Y	Y	Y	5-63
F11	(Overload detection level)	0.00 (disable), current value of 1 to 135% of inverter rated current (Inverter rated current dependent on F80)	Y	Y1 Y2	*3	Y	Y	Y	Y	Y	
F12	(Thermal time constant)	0.5 to 75.0 min	Y	Y	*4	Y	Y	Y	Y	Y	

Factory Default: set for Europe
 indicates quick setup target function code.
 *2: Factory defaults are depended on motor capacity. Refer to "5.2.3 Factory default value per applicable electric motor capacitance".
 *3: The motor rated current is automatically set. Refer to the VXT User's Manual, "5.2.4 Motor constant".
 *4: 5.0min for inverters of nominal applied motor 22kW or below; 10.0min for those of 30kW or above.
 *5: Available at ROM version 0300 or later.
 *10:6.00s for inverters of nominal applied motor 22kW or below; 20.0s for those of 30kW or above.

5.2 Function Codes Table

Code	Name	Data setting range	Change when running	Data copying	Factory Default	Drive control					Related page
						V/f	PG V/f	w/ PG	Torque control	PM	
F14	Restart mode after momentary power failure (Mode selection)	0: Trip immediately 1: Trip after a recovery from power failure 2: Trip after momentary deceleration is stopped 3: Continue to run (for heavy inertia load or general load) 4: Restart from frequency at power failure (for general load) 5: Restart from starting frequency	Y	Y	0	Y	Y	Y	N	Y	5-66
F15	Frequency limiter (Upper limit)	0.0 to 500.0Hz	Y	Y	70.0	Y	Y	Y	N	Y	5-73
F16	(Lower limit)	0.0 to 500.0Hz	Y	Y	0.0	Y	Y	Y	N	Y	
F18	Bias (for frequency setting 1)	-100.00 to 100.00%	Y*	Y	0.00	Y	Y	Y	N	Y	5-73
F20	DC braking 1 (Braking starting frequency)	0.0 to 60.0Hz	Y	Y	0.0	Y	Y	Y	N	Y	5-74
F21	(Braking level)	0 to 100% (HHD mode), 0 to 80% (HD/HND mode) 0 to 60% (ND mode)	Y	Y	0	Y	Y	Y	N	Y	
F22	(Braking time)	0.00 (Disable): 0.01 to 30.00 s	Y	Y	0.00	Y	Y	Y	N	Y	
F23	Starting frequency 1	0.0 to 60.0Hz	Y	Y	0.5	Y	Y	Y	N	Y	5-77
F24	(Holding time)	0.00 to 10.00 s	Y	Y	0.00	Y	Y	Y	N	Y	
F25	Stop frequency	0.0 to 60.0 Hz	Y	Y	0.2	Y	Y	Y	N	Y	
F26	Motor sound (Carrier frequency)	ND mode - 0.75 to10 kHz (VXT-2A-4 to VXT-59A-4) - 0.75 to10 kHz (VXT-12A-2 to VXT-20A-2) - 0.75 to 6 kHz (VXT-72A-4 or above) HD/HND mode - 0.75 to16 kHz (VXT-4A-2 to VXT-88A-2) - 0.75 to16 kHz (VXT-2A-4 to VXT-59A-4) - 0.75 to10 kHz (VXT-7-4 to VXT-168A-4) - 0.75 to10 kHz (VXT-115A-2) - 0.75 to 6 kHz (VXT-203A-4 or above) HHD mode - 0.75 to16 kHz (VXT-4A-2 to VXT-115A-2) - 0.75 to16 kHz (VXT-3A-1 to VXT-11A-1) - 0.75 to16 kHz (VXT-2A-4 to VXT-168A-4) - 0.75 to10 kHz (VXT-203A-4 or above)	Y	Y	2	Y	Y	Y	Y	Y	5-80
F27	(Tone)	0: Level 0 (Disable) 1 to 3 : Level 1 to 3	Y	Y	0	Y	Y	N	N	N	
F29	Terminal FM (Mode selection)	0: Voltage output (0 to +10 VDC) 1: Current output (4 to 20 mA DC) 2: Current output (0 to 20 mA DC) 3: Pulse output	Y	Y	0	Y	Y	Y	Y	Y	5-81
F30	(Output gain)	0 to 300%	Y*	Y	100	Y	Y	Y	Y	Y	
F31	(Function selection)	0: Output frequency 1 (before slip compensation) 1: Output frequency 2 (after slip compensation) 2: Output current 3: Output voltage 4: Output torque 5: Load factor 6: Input power 7: PID feedback value 8: Actual speed/estimated speed *5 9: DC link bus voltage 10: Universal AO 13: Motor output 14: Calibration (+) 15: PID command (SV) 16: PID output (MV) 17: Position error in master-follower operation *5 18: Inverter heat sink temperature 21: PG feedback value *5 111 to 120 Customizable logic output signal 1 to 10	Y	Y	0	Y	Y	Y	N	Y	
F32	Terminal FM 2 *1 (Mode selection)	0: Voltage output (0 to +10 VDC) 1: Current output (4 to 20 mA DC) 2: Current output (0 to 20 mA DC)	Y	Y	0	Y	Y	Y	Y	Y	
F33	Terminal FM (Pulse rate)	25 to 32000 p/s (number of pulse at monitor value 100%)	Y*	Y	1440	Y	Y	Y	Y	Y	
F34	Terminal FM 2 *1 (Output gain)	0 to 300%	Y*	Y	100	Y	Y	Y	Y	Y	
F35	(Function selection)	Same as F31	Y	Y	2	Y	Y	Y	N	Y	

Factory Default: set for Europe

 indicates quick setup target function code.

*1: F34 and F35 only exist for GB model and C model (for China).

*5: Available at ROM version 0300 or later.

5.2 Function Codes Table

Code	Name	Data setting range	Change when running	Data copying	Factory Default	Drive control					Related page
						V/f	PG V/f	w/ PG	Torque control	PM	
F37	Load selection/ Auto torque boost/ Auto energy-saving operation 1	0: Variable torque load 1: Constant torque load 2: Auto torque boost 3: Auto energy-saving operation (variable torque load) 4: Auto energy-saving operation (constant torque load) 5: Auto energy-saving operation with auto torque boost	N	Y	1	Y	Y	Y	N	N	5-84
F38	Stop frequency (Detection mode) *5	0: Actual speed / estimated speed 1: Reference speed	N	Y	0	N	N	Y	N	N	5-86
F39	Stop frequency (Holding time)	0.00 to 10.00 s	Y	Y	0.00	Y	Y	Y	N	Y	
F40	Torque limiter 1 (Driving)	0 to 300%; 999 (Disable)	Y	Y	999	Y	Y	Y	Y	Y	5-86
F41	(Braking)	0 to 300%; 999 (Disable)	Y	Y	999	Y	Y	Y	Y	Y	
F42	Drive control selection 1	0: V/f control without slip compensation 1: Vector control without speed sensor (dynamic torque vector) 2: V/f control with slip compensation 3: V/f control with speed sensor *5 4: V/f control with speed sensor and auto torque boost *5 6: Vector control for induction motor with speed sensor *5 15: Vector control for synchronous motor without speed sensor nor pole position sensor *5	N	Y	0	Y	Y	Y	Y	Y	5-92
F43	Current limiter (Mode selection)	0: Disable (No current limiter works.) 1: Enable at constant speed (Disable during ACC/DEC) 2: Enable during ACC/constant speed operation	Y	Y	2	Y	Y	N	N	N	5-96
F44	(Level)	20 to 200% (Rated current of the inverter for 100%)	Y	Y	130	Y	Y	N	N	N	
F50	Electronic thermal overload protection for braking resistor (Discharging capacity)	1 to 9000 kW OFF (Cancel)	Y	Y1 Y2	OFF	Y	Y	Y	Y	Y	5-97
F51	(Allowable average loss)	0.001 to 99.99 kW	Y	Y1 Y2	0.001	Y	Y	Y	Y	Y	
F52	(Braking resistance value)	0.00: Resistance not required (Compatible mode with Jaguar VXR series) 0.01 to 999 Ω	Y	Y1 Y2	0.00	Y	Y	Y	Y	Y	
F80	Switching between ND, HD, HND and HHD drive modes	0: HHD mode 1: HND mode 3: HD mode 4: ND mode ND/HD mode is not supported for 200V class series.	N	Y	4	Y	Y	Y	Y	Y	5-99

Factory Default: set for Europe

*5: Available at ROM version 0300 or later.

■ E code: Extension Terminal Functions (Terminal function)

Code	Name	Data setting range	Change when running	Data copying	Factory Default	Drive control					Related page
						V/f	PG V/f	w/ PG	Torque control	PM	
E01	Terminal [X1] function	0 (1000): Select multistep frequency (0 to 1 steps) "SS1"	N	Y	0	Y	Y	Y	N	Y	5-100
E02	Terminal [X2] function	1 (1001): Select multistep frequency (0 to 3 steps) "SS2"	N	Y	1	Y	Y	Y	N	Y	
E03	Terminal [X3] function	2 (1002): Select multistep frequency (0 to 7 steps) "SS4"	N	Y	2	Y	Y	Y	N	Y	
E04	Terminal [X4] function	3 (1003): Select multistep frequency (0 to 15 steps) "SS8"	N	Y	7	Y	Y	Y	N	Y	
E05	Terminal [X5] function	4 (1004): Select ACC/DEC time (2 steps) "RT1"	N	Y	8	Y	Y	Y	N	Y	
		5 (1005): Select ACC/DEC time (4 steps) "RT2"				Y	Y	Y	N	Y	
		6 (1006): Select 3-wire operation "HLD"				Y	Y	Y	N	Y	
		7 (1007): Coast to a stop command "BX"				Y	Y	Y	Y	Y	
		8 (1008): Reset alarm (Abnormal) "RST"				Y	Y	Y	Y	Y	
		9 (1009): External alarm (9 = Active OFF/ 1009 = Active ON) "THR"				Y	Y	Y	Y	Y	
		10 (1010): Ready for jogging "JOG"				Y	Y	Y	N	N	
		11 (1011): Select frequency setting 2/ frequency setting 1 "Hz2/ Hz1"				Y	Y	Y	N	Y	
		12 (1012): Select motor 2 "M2"				Y	Y	Y	Y	Y	
		13: DC braking command "DCBRK"				Y	Y	Y	N	N	
		14 (1014): Select torque limit 2/ torque limit 1 "TL2/ TL1"				Y	Y	Y	Y	Y	
		15: Switch to commercial power (50 Hz) "SW50"				Y	Y	N	N	N	
		16: Switch to commercial power (60 Hz) "SW60"				Y	Y	N	N	N	
		17 (1017): UP command "UP"				Y	Y	Y	N	Y	
		18 (1018): DOWN command "DOWN"				Y	Y	Y	N	Y	
		19 (1019): Allow function code editing (Data change enabled) "WE-KP"				Y	Y	Y	Y	Y	
		20 (1020): Cancel PID control "Hz/PID"				Y	Y	Y	N	Y	
		21 (1021): Switch normal/ inverse operation "IVS"				Y	Y	Y	N	Y	
		22 (1022): Interlock "IL"				Y	Y	Y	Y	Y	
		23 (1023): Cancel torque control *5 "Hz/TRQ"				N	N	N	Y	N	
		24 (1024): Select link operation (RS-485, BUS option) "LE"				Y	Y	Y	Y	Y	
		25 (1025): Universal DI "U-DI"				Y	Y	Y	Y	Y	
		26 (1026): Select auto search for idling motor speed at starting "STM"				Y	Y	N	N	Y	
		30 (1030): Force to stop (30 = Active OFF/1030 = Active ON) "STOP"				Y	Y	Y	Y	Y	
		32 (1032): Pre-excite *5 "EXITE"				N	N	Y	Y	N	
		33 (1033): Reset PID integral and differential terms "PID-RST"				Y	Y	Y	N	Y	
		34 (1034): Hold PID integral term "PID-HLD"				Y	Y	Y	N	Y	
		35 (1035): Select local (Keypad) command "LOC"				Y	Y	Y	Y	Y	
		42 (1042): Activate the limit switch at start point *5 "LS"				Y	Y	N	N	N	
		43 (1043): Start / Reset *5 "S/R"				Y	Y	N	N	N	
		44 (1044): Switch to the serial pulse receiving mode *5 "SPRM"				Y	Y	N	N	N	
		45 (1045): Enter the return mode *5 "RTN"				Y	Y	N	N	N	
		46 (1046): Enable overload stop "OLS"				Y	Y	Y	N	Y	
		47 (1047): Servo lock command *5 "LOCK"				N	N	Y	N	N	
		48: Pulse train input (Only for X5 terminal (E05)) "PIN"				Y	Y	Y	N	Y	
		49 (1049): Pulse train sign (Other than X5 terminal (E01 to E04)) "SIGN"				Y	Y	Y	N	Y	
		59 (1059): Enable battery-driven operation *11 "BATRY/UPS"				Y	Y	Y	N	N	
		60 (1060): Select torque bias1 *5 "TB1"				N	N	Y	N	N	
		61 (1061): Select torque bias2 *5 "TB2"				N	N	Y	N	N	
		62 (1062): Hold torque bias *5 "H-TB"				N	N	Y	N	N	
		65 (1065): Check brake "BRKE"				Y	Y	Y	N	N	
		70 (1070): Cancel line speed control *5 "Hz/LSC"				Y	Y	Y	N	N	

*5: Available at ROM version 0300 or later.

*11: Available at ROM version 0500 or later.

5.2 Function Codes Table

Code	Name	Data setting range	Change when running	Data copying	Factory Default	Drive control					Related page
						V/f	PG V/f	w/PG	Torque control	PM	
		71 (1071): Hold line speed control frequency in the memory *5 "LSC-HLD"				Y	Y	Y	N	N	
		72 (1072): Count the run time of commercial power-driven motor 1 *5 "CRUN-M1"				Y	Y	Y	Y	N	
		73 (1073): Count the run time of commercial power-driven motor 2 *5 "CRUN-M2"				Y	Y	Y	Y	N	
		76 (1076): Select droop control "DROOP"				Y	Y	Y	N	N	
		78 (1078): Select speed control parameter 1 *5 "MPRM1"				N	Y	Y	Y	Y	
		79 (1079): Select speed control parameter 2 *5 "MPRM2"				N	Y	Y	Y	Y	
		80 (1080): Cancel customizable logic "CLC"				Y	Y	Y	Y	Y	
		81 (1081): Clear all customizable logic timers "CLTC"				Y	Y	Y	Y	Y	
		82 (1082): Cancel anti-regenerative control "AR-CCL"				Y	Y	Y	N	Y	
		100: No function assigned "NONE"				Y	Y	Y	Y	Y	
		171 (1171): PID control multistage command 1 "PID-SS1"				Y	Y	Y	N	Y	
		172 (1172): PID control multistage command 2 "PID-SS2"				Y	Y	Y	N	Y	
		* Inside the () is the negative logic signal (OFF at short-circuit)									
E10	Acceleration time2	0.00 to 6000 s	Y	Y	6.00 or 20.0 *10	Y	Y	Y	N	Y	5-116
E11	Deceleration time2	* 0.00 is for acceleration and deceleration time cancel (when performing soft-start and stop externally)	Y	Y		Y	Y	Y	N	Y	
E12	Acceleration time 3		Y	Y		Y	Y	Y	N	Y	
E13	Deceleration time 3		Y	Y		Y	Y	Y	N	Y	
E14	Acceleration time 4		Y	Y		Y	Y	Y	N	Y	
E15	Deceleration time 4		Y	Y		Y	Y	Y	N	Y	
E16	Torque limiter 2 (Driving)	0 to 300%; 999 (Disable)	Y	Y	999	Y	Y	Y	Y	Y	5-116
E17	(Braking)	0 to 300%; 999 (Disable)	Y	Y	999	Y	Y	Y	Y	Y	
E20	Terminal [Y1] function	0 (1000): Inverter running "RUN"	N	Y	0	Y	Y	Y	Y	Y	5-117
E21	Terminal [Y2] function	1 (1001): Frequency (speed) arrival "FAR"	N	Y	7	Y	Y	Y	N	Y	
E27	Terminal [30A/B/C] function (Relay output)	2 (1002): Frequency (speed) detected "FDT"	N	Y	99	Y	Y	Y	Y	Y	
		3 (1003): Under voltage detected (inverter stopped) "LU"				Y	Y	Y	Y	Y	
		4 (1004): Detected torque polarity "B/D"				Y	Y	Y	Y	Y	
		5 (1005): Inverter output limiting "IOL"				Y	Y	Y	Y	Y	
		6 (1006): Auto-restarting after momentary power failure "IPF"				Y	Y	Y	Y	Y	
		7 (1007): Motor overload early warning "OL"				Y	Y	Y	Y	Y	
		8 (1008): Keypad operation enabled "KP"				Y	Y	Y	Y	Y	
		10 (1010): Inverter ready to run "RDY"				Y	Y	Y	Y	Y	
		15 (1015): Switch MC on the input power lines "AX"				Y	Y	Y	Y	Y	
		16 (1016): Pattern operation stage transition "TU"				Y	Y	Y	N	Y	
		17 (1017): Pattern operation cycle completed "TO"				Y	Y	Y	N	Y	
		18 (1018): Pattern operation stage 1 "STG1"				Y	Y	Y	N	Y	
		19 (1019): Pattern operation stage 2 "STG2"				Y	Y	Y	N	Y	
		20 (1020): Pattern operation stage 4 "STG4"				Y	Y	Y	N	Y	
		21 (1021): Frequency (speed) arrival 2 "FAR2"				Y	Y	Y	N	Y	
		22 (1022): Inverter output limiting with delay "IOL2"				Y	Y	Y	Y	Y	
		25 (1025): Cooling fan in operation "FAN"				Y	Y	Y	Y	Y	
	26 (1026): Auto-resetting "TRY"				Y	Y	Y	Y	Y		
	27 (1027): Universal DO "U-DO"				Y	Y	Y	Y	Y		
	28 (1028): Heat sink overheat early warning "OH"				Y	Y	Y	Y	Y		
	29 (1029): Synchronization completed *5 "SY"				N	Y	Y	N	N		
	30 (1030): Lifetime alarm "LIFE"				Y	Y	Y	Y	Y		
	31 (1031): Frequency (speed) detected 2 "FDT2"				Y	Y	Y	Y	Y		
	33 (1033): Reference loss detected "REF OFF"				Y	Y	Y	N	Y		
	35 (1035): Inverter outputting "RUN 2"				Y	Y	Y	Y	Y		
	36 (1036): Overload prevention controlling "OLP"				Y	Y	Y	N	Y		
	37 (1037): Current detected "ID"				Y	Y	Y	Y	Y		
	38 (1038): Current detected 2 "ID2"				Y	Y	Y	Y	Y		
	39 (1039): Current detected 3 "ID3"				Y	Y	Y	Y	Y		

*5: Available at ROM version 0300 or later.

*10:6.00s for inverters of nominal applied motor 22kW or below; 20.0s for those of 30kW or above.

5.2 Function Codes Table

Code	Name	Data setting range	Change when running	Data copying	Factory Default	Drive control					Related page
						V/f	PG V/f	w/PG	Torque control	PM	
		41 (1041): Low current detected "IDL"				Y	Y	Y	Y	Y	
		42 (1042): PID alarm "PID-ALM"				Y	Y	Y	N	Y	
		43 (1043): Under PID control "PID-CTL"				Y	Y	Y	N	Y	
		44 (1044): Under sleep mode of PID control "PID-STP"				Y	Y	Y	N	Y	
		45 (1045): Low torque detected "U-TL"				Y	Y	Y	Y	Y	
		46 (1046): Torque detected 1 "TD1"				Y	Y	Y	Y	Y	
		47 (1047): Torque detected 2 "TD2"				Y	Y	Y	Y	Y	
		48 (1048): Motor 1 selected "SWM1"				Y	Y	Y	Y	Y	
		49 (1049): Motor 2 selected "SWM2"				Y	Y	Y	Y	Y	
		52 (1052): Running forward "FRUN"				Y	Y	Y	Y	Y	
		53 (1053): Running reverse "RRUN"				Y	Y	Y	Y	Y	
		54 (1054): Under remote mode "RMT"				Y	Y	Y	Y	Y	
		56 (1056): Motor overheat detected by thermistor "THM"				Y	Y	Y	Y	Y	
		57 (1057): Brake control "BRKS"				Y	Y	Y	N	N	
		58 (1058): Frequency (speed) detected 3 "FDT3"				Y	Y	Y	Y	Y	
		59 (1059): Terminal [C1] (C1 function) wire break detected "C1OFF"				Y	Y	Y	Y	Y	
		70 (1070): Speed valid *5 "DNZS"				N	Y	Y	Y	Y	
		71 (1071): Speed agreement *5 "DSAG"				N	Y	Y	N	Y	
		72 (1072): Frequency (speed) arrival 3 "FAR3"				Y	Y	Y	N	Y	
		76 (1076): PG error detected *5 "PG-ERR"				N	Y	Y	N	Y	
		77 (1077): Low DC link bus voltage detection "U-EDC"				Y	Y	Y	Y	Y	
		79 (1079): During decelerating at momentary power failure "IPF2"				Y	Y	Y	Y	Y	
		80 (1080): Stop position override alarm *5 "OT"				N	Y	N	N	N	
		81 (1081): Under positioning *5 "TO"				N	Y	N	N	N	
		82 (1082): Positioning completed *5 "PSET"				N	Y	Y	N	N	
		83 (1083): Current position count over-flowed *5 "POF"				N	Y	N	N	N	
		84 (1084): Maintenance timer counted up "MNT"				Y	Y	Y	Y	Y	
		87 (1087): Frequency arrival and detected "FARFDT"				Y	Y	Y	N	Y	
		90 (1090): Alarm content 1 "AL1"				Y	Y	Y	Y	Y	
		91 (1091): Alarm content 2 "AL2"				Y	Y	Y	Y	Y	
		92 (1092): Alarm content 4 "AL4"				Y	Y	Y	Y	Y	
		93 (1093): Alarm content 8 "AL8"				Y	Y	Y	Y	Y	
		98 (1098): Light alarm "L-ALM"				Y	Y	Y	Y	Y	
		99 (1099): Alarm output "ALM"				Y	Y	Y	Y	Y	
		101 (1101): EN circuit failure detected "DECF"				Y	Y	Y	Y	Y	
		102 (1102): EN terminal input OFF "ENOFF"				Y	Y	Y	Y	Y	
		105 (1105): Braking transistor broken "DBAL"				Y	Y	Y	Y	Y	
		111 (1111): Customizable logic output signal 1 "CLO1"				Y	Y	Y	Y	Y	
		112 (1112): Customizable logic output signal 2 "CLO2"				Y	Y	Y	Y	Y	
		113 (1113): Customizable logic output signal 3 "CLO3"				Y	Y	Y	Y	Y	
		114 (1114): Customizable logic output signal 4 "CLO4"				Y	Y	Y	Y	Y	
		115 (1115): Customizable logic output signal 5 "CLO5"				Y	Y	Y	Y	Y	
		116 (1116): Customizable logic output signal 6 "CLO6"				Y	Y	Y	Y	Y	
		117 (1117): Customizable logic output signal 7 "CLO7"				Y	Y	Y	Y	Y	
		118 (1118): Customizable logic output signal 8 "CLO8"				Y	Y	Y	Y	Y	
		119 (1119): Customizable logic output signal 9 "CLO9"				Y	Y	Y	Y	Y	
		120 (1120): Customizable logic output signal 10 "CLO10"				Y	Y	Y	Y	Y	
		* Inside the () is written the negative logic signal setting (OFF at short-circuit)									
E29	Frequency arrival delay timer (FAR2)	0.01 to 10.00 s	Y	Y	0.10	Y	Y	Y	N	Y	5-126
E30	Frequency arrival detection width (Detection width)	0.0 to 10.0 Hz	Y	Y	2.5	Y	Y	Y	N	Y	

*5: Available at ROM version 0300 or later.

5.2 Function Codes Table

Code	Name	Data setting range	Change when running	Data copying	Factory Default	Drive control					Related page
						V/f	PG V/f	w/ PG	Torque control	PM	
E31	Frequency detection 1 (Level)	0.0 to 500.0 Hz	Y	Y	50.0	Y	Y	Y	N	Y	5-128
E32	(Hysteresis width)	0.0 to 500.0 Hz	Y	Y	1.0	Y	Y	Y	N	Y	
E34	Overload early warning/Current detection (Level)	0.00 (Disable), 1 to 200% of inverter rated current (Inverter rated current dependent on F80)	Y	Y1 Y2	*3	Y	Y	Y	Y	Y	5-129
E35	(Timer)	0.01 to 600.00 s	Y	Y	10.00	Y	Y	Y	Y	Y	
E36	Frequency detection 2 (Level)	0.0 to 500.0 Hz	Y	Y	50.0	Y	Y	Y	Y	Y	5-130
E37	Current detection 2/ Low current detection (Level)	0.00 (Disable), 1 to 200% of inverter rated current (Inverter rated current dependent on F80)	Y	Y1 Y2	*3	Y	Y	Y	Y	Y	5-130
E38	(Timer)	0.01 to 600.00 s	Y	Y	10.00	Y	Y	Y	Y	Y	
E39	Display coefficient for transport time	0.000 to 9.999	Y	Y	0.000	Y	Y	Y	N	Y	5-130
E42	LED display filter	0.0 to 5.0 s	Y	Y	0.5	Y	Y	Y	Y	Y	5-130
E43	LED monitor (Item selection)	0: Speed monitor (Selectable with E48) 3: Output current 4: Output voltage 8: Calculated torque 9: Input power 10: PID process command 12: PID feedback value 13: Timer value(for timed operation) 14: PID output 15: Load factor 16: Motor output 17: Analog signal input monitor 21: Current position pulse *5 22: Position error pulse *5 23: Torque current (%) *5 24: Magnetic flux command(%) *5 25: Input watt-hour	Y	Y	0	Y	Y	Y	Y	Y	5-131
E44	(Display when stopped)	0: Specified value 1: Output value	Y	Y	0	Y	Y	Y	Y	Y	
E48	LED monitor (Speed monitor item)	0: Output frequency 1 (before slip compensation) 1: Output frequency 2 (after slip compensation) 2: Reference frequency 3: Motor rotation speed 4: Load rotation speed 5: Line speed 6: Transport time for specified length 7: Speed (%)	Y	Y	0	Y	Y	Y	Y	Y	5-132
E49	Torque Command Monitor *5 (Polarity selection)	0: Torque polarity 1: Plus for driving, Minus for braking	Y	Y	1	Y	Y	Y	Y	Y	5-132
E50	Display coefficient for speed monitor	0.01 to 200.00	Y	Y	30.00	Y	Y	Y	Y	Y	5-133
E51	Display coefficient for "Input watt-hour data"	0.000 (Cancel/Reset). 0.001 to 9999	Y	Y	0.010	Y	Y	Y	Y	Y	5-133
E52	Keypad (Menu display mode)	0: Function code data setting mode (Menu 0, Menu1, and Menu 7) 1: Function code data check mode (Menu 2 and Menu 7) 2: Full-menu mode	Y	Y	0	Y	Y	Y	Y	Y	5-134
E54	Frequency detection 3 (Level)	0.0 to 500.0Hz	Y	Y	:50.0	Y	Y	Y	Y	Y	5-134
E55	Current detection 3 (Level)	0.00 (Disable), 1 to 200% of inverter rated current (Inverter rated current dependent on F80)	Y	Y1 Y2	*3	Y	Y	Y	Y	Y	5-134
E56	(Timer)	0.01 to 600.00 s	Y	Y	10.00	Y	Y	Y	Y	Y	

Factory Default: set for Europe

E52 indicates quick setup target function code.

*3: The motor rated current is automatically set. Refer to Refer to the VXT User's Manual, "5.2.4 Motor constant" (function code P03).

*5: Available at ROM version 0300 or later.

5.2 Function Codes Table

Code	Name	Data setting range	Change when running	Data copying	Factory Default	Drive control					Related page
						V/f	PG V/f	w/ PG	Torque control	PM	
E59	Terminal [C1] function selection	0: Current input (C1 function) 1: Voltage input (V2 function)	N	Y	0	Y	Y	Y	Y	Y	5-135
E61	Terminal [12] extended function	0: None 1: Auxiliary frequency setting 1 2: Auxiliary frequency setting 2	N	Y	0	Y	Y	Y	Y	Y	5-136
E62	Terminal [C1] (C1 extended function)	3: PID process command 5: PID feedback value	N	Y	0	Y	Y	Y	Y	Y	
E63	Terminal [C1] (V2 extended function)	6: Ratio setting 7: Analog torque limiter A 8: Analog torque limiter B 9: Torque bias *5 10: Torque command *5 11: Torque current command *5 17: Speed limit for forward rotation *5 18: Speed limit for reverse rotation *5 20: Analog signal input monitor	N	Y	0	Y	Y	Y	Y	Y	
E64	Saving of digital reference frequency	0: Auto saving (main power is turned off) 1: Save by turning  key ON	Y	Y	0	Y	Y	Y	Y	Y	5-136
E65	Reference loss detection	0: Stop deceleration 20 to 120%, 999: Cancel	Y	Y	999	Y	Y	Y	N	Y	5-137
E76	DC link bus low-voltage detection level	200 to 400 V (200 V class) 400 to 800 V (400 V class)	Y	Y	235 470	Y	Y	Y	Y	Y	5-137
E78	Torque detection 1 (Level)	0 to 300%	Y	Y	100	Y	Y	Y	Y	Y	5-138
E79	(Timer)	0.01 to 600.00 s	Y	Y	10.00	Y	Y	Y	Y	Y	
E80	Torque detection 2/ low torque detection (Level)	0 to 300%	Y	Y	20	Y	Y	Y	Y	Y	5-138
E81	(Timer)	0.01 to 600.00 s	Y	Y	20.00	Y	Y	Y	Y	Y	
E98	Terminal [FWD] function	0 (1000): Select multistep frequency (0 to 1 steps) "SS1"	N	Y	98	Y	Y	Y	N	Y	5-138
E99	Terminal [REV] function	1 (1001): Select multistep frequency (0 to 3 steps) "SS2"	N	Y	99	Y	Y	Y	N	Y	
		2 (1002): Select multistep frequency (0 to 7 steps) "SS4"				Y	Y	Y	N	Y	
		3 (1003): Select multistep frequency (0 to 15 steps) "SS8"				Y	Y	Y	N	Y	
		4 (1004): Select ACC/DEC time (2 steps) "RT1"				Y	Y	Y	N	Y	
		5 (1005): Select ACC/DEC time (4 steps) "RT2"				Y	Y	Y	N	Y	
		6 (1006): Select 3-wire operation "HLD"				Y	Y	Y	N	Y	
		7 (1007): Coast to a stop command "BX"				Y	Y	Y	Y	Y	
		8 (1008): Reset alarm (Abnormal) "RST"				Y	Y	Y	Y	Y	
		9 (1009): External alarm (9 = Active OFF/1009 = Active ON) "THR"				Y	Y	Y	Y	Y	
		10 (1010): Ready for jogging "JOG"				Y	Y	Y	N	N	
		11 (1011): Select frequency setting 2/ frequency setting 1 "Hz2/ Hz1"				Y	Y	Y	N	Y	
		12 (1012): Select Motor 2 "M2"				Y	Y	Y	Y	Y	
		13: DC braking command "DCBRK"				Y	Y	Y	N	N	
		14 (1014): Select torque limit 2/ torque limit 1 "TL2/ TL1"				Y	Y	Y	Y	Y	
		15: Switch to commercial power (50 Hz) "SW50"				Y	Y	N	N	N	
		16: Switch to commercial power (60 Hz) "SW60"				Y	Y	N	N	N	
		17 (1017): UP command "UP"				Y	Y	Y	N	Y	
		18 (1018): DOWN command "DOWN"				Y	Y	Y	N	Y	
		19 (1019): Allow function code editing (Data change enabled) "WE-KP"				Y	Y	Y	Y	Y	
		20 (1020): Cancel PID control "Hz/PID"				Y	Y	Y	N	Y	
		21 (1021): Switch normal/ inverse operation "IVS"				Y	Y	Y	N	Y	
		22 (1022): Interlock "IL"				Y	Y	Y	Y	Y	
		23 (1023): Cancel torque control *5 "Hz/TRQ"				N	N	N	Y	N	
		24 (1024): Select link operation (RS-485, BUS option) "LE"				Y	Y	Y	Y	Y	
		25 (1025): Universal DI "U-DI"				Y	Y	Y	Y	Y	
		26 (1026): Select auto search for idling motor speed at starting "STM"				Y	Y	N	N	Y	
		30 (1030): Force to stop (30 = Active OFF/1030 = Active ON) "STOP"				Y	Y	Y	Y	Y	
		32 (1032): Pre-excite *5 "EXITE"				N	N	Y	Y	N	

*5: Available at ROM version 0300 or later.

5.2 Function Codes Table

Code	Name	Data setting range	Change when running	Data copying	Factory Default	Drive control					Related page
						V/f	PG V/f	w/PG	Torque control	PM	
		33 (1033): Reset PID integral and differential terms "PID-RST"				Y	Y	Y	N	Y	
		34 (1034): Hold PID integral term "PID-HLD"				Y	Y	Y	N	Y	
		35 (1035): Select local (Keypad) command "LOC"				Y	Y	Y	Y	Y	
		42 (1042): Activate the limit switch at start point *5 "LS"				Y	Y	N	N	N	
		43 (1043): Start / Reset *5 "S/R"				Y	Y	N	N	N	
		44 (1044): Switch to the serial pulse receiving mode *5 "SPRM"				Y	Y	N	N	N	
		45 (1045): Enter the return mode *5 "RTN"				Y	Y	N	N	N	
		46 (1046): Enable overload stop "OLS"				Y	Y	Y	N	Y	
		47 (1047): Servo lock command *5 "LOCK"				N	N	Y	N	N	
		49 (1049): Pulse train sign "SIGN"				Y	Y	Y	N	Y	
		59 (1059): Enable battery-driven operation *11 "BATRY/UPS"				Y	Y	Y	N	N	
		60 (1060): Select torque bias 1 *5 "TB1"				N	N	Y	N	N	
		61 (1061): Select torque bias 2 *5 "TB2"				N	N	Y	N	N	
		62 (1062): Hold torque bias *5 "H-TB"				N	N	Y	N	N	
		65 (1065): Check brake "BRKE"				Y	Y	Y	N	N	
		70 (1070): Cancel line speed control *5 "Hz/LSC"				Y	Y	Y	N	N	
		71 (1071): Hold line speed control frequency in the memory *5 "LSC-HLD"				Y	Y	Y	N	N	
		72 (1072): Count the run time of commercial power-driven motor 1 *5 "CRUN-M1"				Y	Y	Y	Y	N	
		73 (1073): Count the run time of commercial power-driven motor 2 *5 "CRUN-M2"				Y	Y	Y	Y	N	
		76 (1076): Select droop control "DROOP"				Y	Y	Y	N	N	
		78 (1078): Select speed control parameter 1 *5 "MPRM1"				N	Y	Y	Y	Y	
		79 (1079): Select speed control parameter 2 *5 "MPRM2"				N	Y	Y	Y	Y	
		80 (1080): Cancel customizable logic "CLC"				Y	Y	Y	Y	Y	
		81 (1081): Clear all customizable logic timers "CLTC"				Y	Y	Y	Y	Y	
		82 (1082): Cancel anti-regenerative control "AR-CCL"				Y	Y	Y	N	Y	
		98: Run forward / stop command "FWD"				Y	Y	Y	Y	Y	
		99: Run reverse / stop command "REV"				Y	Y	Y	Y	Y	
		100: No function assigned "NONE"				Y	Y	Y	Y	Y	
		171 (1171): PID control multistage command 1 "PID-SS1"				Y	Y	Y	N	Y	
		172 (1172): PID control multistage command 2 "PID-SS2"				Y	Y	Y	N	Y	
		* Inside the () is the negative logic signal. (OFF at short-circuit)									

*5: Available at ROM version 0300 or later.

*11: Available at ROM version 0500 or later.

■ C code: Control Functions of Frequency (Control function)

Code	Name	Data setting range	Change when running	Data copying	Factory Default	Drive control					Related page
						V/f	PG V/f	w/ PG	Torque control	PM	
C01	Jump frequency 1 2 3 (Skip width)	0.0 to 500.0Hz	Y	Y	0.0	Y	Y	Y	N	Y	5-139
C02			Y	Y	0.0	Y	Y	Y	N	Y	
C03			Y	Y	0.0	Y	Y	Y	N	Y	
C04		0.0 to 30.0Hz	Y	Y	3.0	Y	Y	Y	N	Y	
C05	Multistep frequency 1 2 3 4 5 6 7 8 9 10 11 12 13 14 15	0.00 to 500.00Hz	Y	Y	0.00	Y	Y	Y	N	Y	5-140
C06			Y	Y	0.00	Y	Y	Y	N	Y	
C07			Y	Y	0.00	Y	Y	Y	N	Y	
C08			Y	Y	0.00	Y	Y	Y	N	Y	
C09			Y	Y	0.00	Y	Y	Y	N	Y	
C10			Y	Y	0.00	Y	Y	Y	N	Y	
C11			Y	Y	0.00	Y	Y	Y	N	Y	
C12			Y	Y	0.00	Y	Y	Y	N	Y	
C13			Y	Y	0.00	Y	Y	Y	N	Y	
C14			Y	Y	0.00	Y	Y	Y	N	Y	
C15			Y	Y	0.00	Y	Y	Y	N	Y	
C16			Y	Y	0.00	Y	Y	Y	N	Y	
C17			Y	Y	0.00	Y	Y	Y	N	Y	
C18			Y	Y	0.00	Y	Y	Y	N	Y	
C19			Y	Y	0.00	Y	Y	Y	N	Y	
C20	Jogging frequency	0.00 to 500.00 Hz	Y	Y	0.00	Y	Y	Y	N	N	5-140
C21	Pattern operation / timed operation (Mode selection) (Stage 1) (Stage 2) (Stage 3) (Stage 4) (Stage 5) (Stage 6) (Stage 7)	0: 1 cycle operation 1: Repetition operation 2: Constant speed operation after 1 cycle operation 3: Timed operation Special setting: Press key three times. 1st: Set run time 0.0 to 6000 s and press key. 2nd: Set rotational direction F (forward) or r (reverse) and press key. 3rd: Set acceleration/deceleration time 1 to 4 and press key.	N	Y	0	Y	Y	Y	N	Y	5-141
C22			Y	Y	1st: 0.00	Y	Y	Y	N	Y	
C23			Y	Y	2nd: F	Y	Y	Y	N	Y	
C24			Y	Y	3rd: 1	Y	Y	Y	N	Y	
C25			Y	Y		Y	Y	Y	N	Y	
C26			Y	Y		Y	Y	Y	N	Y	
C27			Y	Y		Y	Y	Y	N	Y	
C28			Y	Y		Y	Y	Y	N	Y	
C30	Frequency setting 2	0: Keypad key operation 1: Analog voltage input (Terminal [12]) (from 0 to ±10 VDC) 2: Analog current input (Terminal [C1] (C1 function)) (4 to 20 mA DC, 0 to 20 mA DC) 3: Analog voltage input (Terminal [12]) + Analog current input (Terminal [C1] (C1 function)) 5: Analog voltage input (Terminal [C1] (V2 function)) (0 to 10 VDC) 7: UP DOWN control 8: Keypad key operation (key) (With balanceless bumpless) 10: Pattern operation 11: Digital input/output interface card (option) *5 12: Pulse train input	N	Y	2	Y	Y	Y	N	Y	5-143
C31	Analog input adjustment (Terminal [12]) (Offset) (Gain) (Filter) (Gain base point) (Polarity selection)	-5.0 to 5.0%	Y*	Y	0.0	Y	Y	Y	Y	Y	5-144
C32		0.00 to 200.00%	Y*	Y	100.0	Y	Y	Y	Y	Y	
C33		0.00 to 5.00 s	Y	Y	0.05	Y	Y	Y	Y	Y	
C34		0.00 to 100.00%	Y*	Y	100.0	Y	Y	Y	Y	Y	
C35		0: Bipolar 1: Unipolar	N	Y	1	Y	Y	Y	Y	Y	
C36	Analog input adjustment (Terminal [C1] (C1 function)) (Offset) (Gain) (Filter) (Gain base point)	-5.0 to 5.0%	Y*	Y	0.0	Y	Y	Y	Y	Y	
C37		0.00 to 200.00%	Y*	Y	100.0	Y	Y	Y	Y	Y	
C38		0.00 to 5.00 s	Y	Y	0.05	Y	Y	Y	Y	Y	
C39		0.00 to 100.00%	Y*	Y	100.0	Y	Y	Y	Y	Y	
C40	Terminal [C1] (C1 function) range / polarity selection	0: 4 to 20 mA Unipolar 1: 0 to 20 mA Unipolar 10: 4 to 20 mA Bipolar 11: 0 to 20 mA Bipolar	N	Y	0	Y	Y	Y	Y	Y	

*5: Available at ROM version 0300 or later.

5.2 Function Codes Table

Code	Name	Data setting range	Change when running	Data copying	Factory Default	Drive control					Related page
						V/f	PG V/f	w/ PG	Torque control	PM	
C41	Analog input adjustment (Terminal [C1] (V2 function)) (Offset)	-5.0 to 5.0%	Y*	Y	0.0	Y	Y	Y	Y	Y	
C42	(Gain)	0.00 to 200.00%	Y*	Y	100.0	Y	Y	Y	Y	Y	
C43	(Filter)	0.00 to 5.00 s	Y	Y	0.05	Y	Y	Y	Y	Y	
C44	(Gain base point)	0.00 to 100.00%	Y*	Y	100.0	Y	Y	Y	Y	Y	
C45	(Polarity selection)	0: Bipolar 1: Unipolar	N	Y	1	Y	Y	Y	Y	Y	
C50	Bias (for frequency setting 1) (Bias base point)	0.00 to 100.00%	Y*	Y	0.00	Y	Y	Y	N	Y	5-146
C53	Selection of normal/inverse operation (Frequency setting 1)	0: Normal 1: Inverse	Y	Y	0	Y	Y	Y	N	Y	5-146
C55	Analog input adjustment (Terminal 12) (Bias)	-100.00 to 100.00%	Y	Y	0.00	Y	Y	Y	Y	Y	5-144
C56	(Bias base point)	0.00 to 100.00 %	Y	Y	0.00	Y	Y	Y	Y	Y	
C58	(Display unit)	* Same as J105 (However, setting range is, 1 to 80)	Y	Y	2	Y	Y	Y	Y	Y	5-147
C59	(Maximum scale)	-999.00 to 0.00 to 9990.00	N	Y	100	Y	Y	Y	Y	Y	5-147
C60	(Minimum scale)	-999.00 to 0.00 to 9990.00	N	Y	0.00	Y	Y	Y	Y	Y	
C61	Analog input adjustment (Terminal[C1](C1 function)) (Bias)	-100.00 to 100.00 %	Y	Y	0.00	Y	Y	Y	Y	Y	5-144
C62	(Bias base point)	0.00 to 100.00 %	Y	Y	0.00	Y	Y	Y	Y	Y	
C64	(Display unit)	* Same as J105 (However, setting range is, 1 to 80)	Y	Y	2	Y	Y	Y	Y	Y	5-147
C65	(Maximum scale)	-999.00 to 0.00 to 9990.00	N	Y	100	Y	Y	Y	Y	Y	5-147
C66	(Minimum scale)	-999.00 to 0.00 to 9990.00	N	Y	0.00	Y	Y	Y	Y	Y	
C67	Analog input adjustment (Terminal [C1] (V2 function)) (Bias)	-100.00 to 100.00 %	Y	Y	0.00	Y	Y	Y	Y	Y	5-144
C68	(Bias base point)	0.00 to 100.00 %	Y	Y	0.00	Y	Y	Y	Y	Y	
C70	(Display unit)	* Same as J105 (However, setting range is, 1 to 80)	Y	Y	2	Y	Y	Y	Y	Y	5-147
C71	(Maximum scale)	-999.00 to 0.00 to 9990.00	N	Y	100	Y	Y	Y	Y	Y	5-147
C72	(Minimum scale)	-999.00 to 0.00 to 9990.00	N	Y	0.00	Y	Y	Y	Y	Y	
C89	Frequency correction 1 by (Numerator)	-32768 to 32767 (Keypad display is 8000 to 7FFFH) (Interpreted as 1 when the value is set to 0)	Y	Y	0001	Y	Y	Y	N	Y	—
C90	Frequency correction 2 by (Denominator)	-32768 to 32767 (Keypad display is 8000 to 7FFFH) (Interpreted as 1 when the value is set to 0)	Y	Y	0001	Y	Y	Y	N	Y	—

■ P codes: Motor 1 Parameters (Motor 1 parameter)

Code	Name	Data setting range	Change when running	Data copying	Factory Default	Drive control					Related page
						V/f	PG V/f	w/ PG	Torque control	PM	
P01	Motor 1 (No. of poles)	2 to 22 poles	N	Y1 Y2	4	Y	Y	Y	Y	Y	5-148
P02	(Rated capacity)	0.01 to 1000 kW (At P99 = 0 or 4, 15) 0.01 to 1000 HP (At P99 = 1)	N	Y1 Y2	*6	Y	Y	Y	Y	Y	5-148
P03	(Rated current)	0.00 to 2000A	N	Y1 Y2	*6	Y	Y	Y	Y	Y	5-148
P04	(Auto-tuning)	0: Disable 1: Stop tuning 2: Rotation tuning 5: Stop tuning(%R1, %X) *5	N	N	0	Y	Y	Y	Y	Y	5-149
P05	(Online tuning)	0: Invalid 1: Valid	Y	Y	0	Y	Y	N	N	N	5-150
P06	(No-load current)	0.00 to 2000A	N	Y1 Y2	*6	Y	Y	Y	Y	N	5-151
P07	(%R1)	0.00 to 50.00%	Y	Y1 Y2	*6	Y	Y	Y	Y	N	
P08	(%X)	0.00 to 50.00%	Y	Y1 Y2	*6	Y	Y	Y	Y	N	
P09	(Slip compensation gain for driving)	0.0 to 200.0%	Y*	Y	100.0	Y	Y	Y	N	N	5-151
P10	(Slip compensation response time)	0.01 to 10.00 s	Y	Y1 Y2	0.5	Y	Y	N	N	N	
P11	(Slip compensation gain for braking)	0.0 to 200.0 %	Y*	Y	100.0	Y	Y	Y	N	N	
P12	(Rated slip frequency)	0.00 to 15.00 Hz	N	Y1 Y2	*6	Y	Y	Y	N	N	5-152
P13	(Iron loss factor 1)	0.00 to 20.00 %	Y	Y1 Y2	*6	Y	Y	Y	Y	N	5-152
P16	(Magnetic saturation factor 1) *5	0.0 to 300.0 %	Y	Y1 Y2	*6	N	N	Y	Y	N	5-152
P17	(Magnetic saturation factor 2) *5	0.0 to 300.0 %	Y	Y1 Y2	*6	N	N	Y	Y	N	
P18	(Magnetic saturation factor 3) *5	0.0 to 300.0 %	Y	Y1 Y2	*6	N	N	Y	Y	N	
P19	(Magnetic saturation factor 4) *5	0.0 to 300.0 %	Y	Y1 Y2	*6	N	N	Y	Y	N	
P20	(Magnetic saturation factor 5) *5	0.0 to 300.0 %	Y	Y1 Y2	*6	N	N	Y	Y	N	
P30	(PMSM drive magnetic pole position detection mode) *5	0: Pull-in by current 1: For IPMSM (Interior permanent magnet synchronous motor) 2: For SPMSM (Surface permanent magnet synchronous motor) 3: Pull-in by current for IPMSM (Interior permanent magnet synchronous motor)	N	Y1 Y2	1	N	N	N	N	Y	5-153
P53	(%X correction factor 1) *5	0 to 300 %	Y	Y1 Y2	100	Y	Y	Y	Y	N	5-153
P55	(Torque current under vector control) *5	0.00 to 2000 A	N	Y1 Y2	*6	N	N	Y	Y	N	5-153
P56	(Induced voltage factor under vector control) *5	50 to 100 %	N	Y1 Y2	*6	N	N	Y	Y	N	
P60	(PMSM armature resistance)*5	0.000 to 50.000 ohm	N	Y1 Y2	*7	N	N	N	N	Y	5-153
P61	(PMSM d-axis inductance)*5	0.00 to 500.00 mH	N	Y1 Y2	*7	N	N	N	N	Y	
P62	(PMSM q-axis inductance)*5	0.00 to 500.00 mH	N	Y1 Y2	*7	N	N	N	N	Y	
P63	(PMSM induced voltage)*5	80 to 240V (200V class); 160 to 500V (400Vclass)	N	Y1 Y2	*7	N	N	N	N	Y	
P64	(PMSM iron loss)*5	0.0 to 20.0 %	Y	Y1 Y2	*7	N	N	N	N	Y	
P65	(PMSM d-axis inductance magnetic saturation correction)*5 *9	0.0 to 100.0 % ; 999	Y	Y1 Y2	*7	N	N	N	N	Y	5-154

■ indicates quick setup target function code.

*5: Available at ROM version 0300 or later.

*6: Factory defaults are depended on motor capacity. Refer to the VXT User's Manual, "5.2.4 Motor constant".

*7: Factory defaults are the parameters for IMO standard PMSM and depended on motor capacity.

*9: Factory use. Do not access these function codes.

5.2 Function Codes Table

Code	Name	Data setting range	Change when running	Data copying	Factory Default	Drive control					Related page
						V/f	PG V/f	w/ PG	Torque control	PM	
P74	(PMSM reference current at starting)*5	10 to 200 % (100%= motor rated current)	Y*	Y1 Y2	*7	N	N	N	N	Y	5-154
P83	(Reserved for PMSM)*5 *9	0.0 to 50.0; 999	Y	Y1 Y2	999	N	N	N	N	-	5-154
P84	(Reserved for PMSM)*5 *9	0.0 to 100.0; 999	N	Y1 Y2	999	N	N	N	N	-	
P85	(PMSM flux limitation value)	50.0 to 150.0; 999	Y	Y1 Y2	999	N	N	N	N	Y	5-154
P86	(Reserved for PMSM)	0.0 to 100.0%	N	N	0.0	N	N	N	N	-	5-154
P87	(PMSM reference current for polarity discrimination)	0 to 200 %	N	Y1 Y2	60	N	N	N	N	Y	-
P88	(Reserved for PMSM)*5 *9	0 to 100 %; 999	N	Y1 Y2	999	N	N	N	N	-	5-154
P89	(Reserved for PMSM)*5 *9	0; 1 to 100	N	Y1 Y2	0	N	N	N	N	-	
P90	(PMSM overcurrent protection level)*5	0.00(disable); 0.01 to 2000 A	N	Y1 Y2	*7	N	N	N	N	Y	5-154
P99	Motor 1 selection	0: Motor characteristics 0 1: Motor characteristics 1 (HP rating IMs) 4: Other IMs 20: Other motors(PMSMs) *5 21: Motor characteristics	N	Y1 Y2	0	Y	Y	Y	Y	Y	5-154

P99 indicates quick setup target function code.

Factory Default: set for Europe

*5: Available at ROM version 0300 or later.

*7: Factory defaults are the parameters for IMO standard PMSM and depended on motor capacity.

*9: Factory use. Do not access these function codes.

■ H codes: High Performance Functions (High level function)

Code	Name	Data setting range	Change when running	Data copying	Factory Default	Drive control					Related page	
						V/f	PG V/f	w/ PG	Torque control	PM		
H02	Data initialization (Method)	0: Standard 1: User	N	Y	0	Y	Y	Y	Y	Y	5-155	
H03	(Target)	0: Manual setting value 1: Initial value (factory default value) 2: Initialize motor 1 parameters 3: Initialize motor 2 parameters 11: Initialize the parameters(excluding parameters related to communication) 12: Initialize the parameters related to customizable logic	N	N	0	Y	Y	Y	Y	Y		
H04	Auto-reset (Times)	0: Disable, 1 to 20: Number of retries	Y	Y	0	Y	Y	Y	Y	Y	5-157	
H05	(Interval)	0.5 to 20.0 s	Y	Y	5.0	Y	Y	Y	Y	Y		
H06	Cooling fan ON/OFF control	0: Disable (Always Fan ON) 1: Enable (ON/OFF control effective)	Y	Y	0	Y	Y	Y	Y	Y	5-158	
H07	Curve acceleration/ deceleration	0: Disable (Linear acceleration/deceleration) 1: S-curve acceleration/deceleration (Weak) 2: S-curve acceleration/deceleration (Arbitrary: According to H57 to H60) 3: Curve acceleration/deceleration	Y	Y	0	Y	Y	Y	N	Y	5-158	
H08	Rotational direction limitation	0: Disable 1: Enable (Reverse rotation inhibited) 2: Enable (Forward rotation inhibited)	N	Y	0	Y	Y	Y	N	Y	5-158	
H09	Starting mode (Auto search)	0: Disable 1: Enable (Only at restart after momentary power failure) 2: Enable (At normal start and at restart after momentary power failure)	N	Y	0	Y	Y	N	N	N	5-159	
H11	Deceleration mode	0: Normal deceleration 1: Coast to a stop	Y	Y	0	Y	Y	Y	N	Y	5-161	
H12	Instantaneous overcurrent limiting (Mode selection)	0: Disable 1: Enable	Y	Y	1	Y	Y	N	N	N	5-161	
H13	Restart mode after momentary power failure (Restart timer)	0.1 to 20.0 s	Y	Y1 Y2	*2	Y	Y	Y	N	N	5-161	
H14	(Frequency fall rate)	0.00: Selected deceleration time, 0.01 to 100.00Hz/s, 999 (According to current limiter)	Y	Y	999	Y	Y	N	N	N		
H15	(Continuous running level)	200 to 300V: (200 V class) 400 to 600V: (400V class)	Y	Y2	235 470	Y	Y	Y	N	Y		
H16	(Allowable momentary power failure time)	0.0 to 30.0s, 999 (Depend on inverter judgment)	Y	Y	999	Y	Y	Y	N	Y		
H18	Torque control *5 (Mode selection)	0: Disable (Speed control) 2: Function (Torque current command) 3: Function (Torque command)	N	Y	0	N	N	Y	Y	N	5-162	
H26	Thermistor (for motor) (Mode selection)	0: Disable 1: PTC: θ_{h4} trip and stop the inverter 2: PTC: Output motor overheat detected "THM" and continue to run	Y	Y	0	Y	Y	Y	Y	Y	5-164	
H27	(Level)	0.00 to 5.00 V	Y	Y	1.60	Y	Y	Y	Y	Y		
H28	Droop control	-60.0 to 0.0Hz	Y	Y	0.0	Y	Y	Y	N	N	5-166	
H30	Communication link function (Mode selection)	Frequency command Run command 0: F01/C30 F02 1: RS-485 (Port 1) F02 2: F01/C30 RS-485 (Port 1) 3: RS-485 (Port 1) RS-485 (Port 1) 4: RS-485 (Port 2) F02 5: RS-485 (Port 2) RS-485 (Port 1) 6: F01/C30 RS-485 (Port 2) 7: RS-485 (Port 1) RS-485 (Port 2) 8: RS-485 (Port 2) RS-485 (Port 2)	Y	Y	0	Y	Y	Y	Y	Y	Y	5-167
H42	Capacitance of DC link bus capacitor	For adjustment at replacement (0000 to FFFF (in hexadecimal))	Y	N	-	Y	Y	Y	Y	Y	5-169	
H43	Cumulative run time of cooling fan	For adjustment at replacement Displays the cumulative run time of cooling fan in units of ten hours.	Y	N	-	Y	Y	Y	Y	Y		
H44	Startup count for motor 1	For adjustment at replacement (0000 to FFFF in hexadecimal)	Y	N	-	Y	Y	Y	Y	Y	5-173	
H45	Mock alarm	0: Disable 1: Occurrence of mock Alarm	Y	N	0	Y	Y	Y	Y	Y	5-173	
H46	Starting mode (Auto search delay time 2)	0.1 to 20.0 s	Y	Y1 Y2	*6	Y	Y	N	N	Y	5-173	

*2: Factory defaults are depended on motor capacity. Refer to "5.2.3 Factory default value per applicable electric motor capacitance".

*5: Available at ROM version 0300 or later.

*6: Factory defaults are depended on motor capacity. Refer to the VXT User's Manual, "5.2.4 Motor constant".

5.2 Function Codes Table

Code	Name	Data setting range	Change when running	Data copying	Factory Default	Drive control					Related page
						V/f	PG V/f	w/ PG	Torque control	PM	
H47	Initial capacitance of DC link bus capacitor	For adjustment at replacement (0000 to FFFF in hexadecimal)	Y	N	–	Y	Y	Y	Y	Y	5-173
H48	Cumulative run time of capacitors on printed circuit boards	For adjustment at replacement Change in cumulative motor run time (Reset is enabled) (in units of ten hours)	Y	N	–	Y	Y	Y	Y	Y	5-169 5-173
H49	Starting mode (Auto search delay time 1)	0.0 to 10.0 s	Y	Y	0.0	Y	Y	Y	N	Y	5-174
H50	Non-linear V/f 1 (Frequency)	0.0 (Cancel), 0.1 to 500.0 Hz	N	Y	0.0	Y	Y	N	N	N	5-174
H51	(Voltage)	0 to 240 V:AVR operation (200 V class) 0 to 500V:AVR operation (400V class)	N	Y2	0	Y	Y	N	N	N	
H52	Non-linear V/f 2 (Frequency)	0.0 (Cancel), 0.1 to 500.0 Hz	N	Y	0.0	Y	Y	N	N	N	5-174
H53	(Voltage)	0 to 240V:AVR operation (200V class) 0 to 500V:AVR operation (400V class)	N	Y2	0	Y	Y	N	N	N	
H54	Acceleration time (Jogging)	0.00 to 6000 s	Y	Y	6.00 or 20.0 *10	Y	Y	Y	N	Y	5-174
H55	Deceleration time (Jogging)	0.00 to 6000 s	Y	Y		Y	Y	Y	N	Y	
H56	Deceleration time for forced stop	0.00 to 6000 s	Y	Y		Y	Y	Y	N	Y	
H57	1st S-curve acceleration range (At starting)	0 to 100%	Y	Y	10	Y	Y	Y	N	Y	5-174
H58	2nd S-curve acceleration range (At arrival)	0 to 100%	Y	Y	10	Y	Y	Y	N	Y	
H59	1st S-curve deceleration range (At starting)	0 to 100%	Y	Y	10	Y	Y	Y	N	Y	
H60	2nd S-curve deceleration range (At arrival)	0 to 100%	Y	Y	10	Y	Y	Y	N	Y	
H61	UP/DOWN control (Initial frequency setting)	0: Initial value is 0.00 Hz 1: Last UP/DOWN command value on releasing the run command.	N	Y	1	Y	Y	Y	N	Y	5-174
H63	Low limiter (Mode selection)	0: Limit by F16 (Frequency limiter: Low) and continue to run 1: If the output frequency lowers below the one limited by F16 (Frequency limiter: Low), decelerate to stop the motor.	Y	Y	0	Y	Y	Y	N	Y	5-174
H64	(Lower limiting frequency)	0.0: Depends on F16 (Frequency limiter, Low) 0.1 to 60.0 Hz	Y	Y	1.6	Y	Y	N	N	Y	5-174
H65	Non-linear V/f 3 (Frequency)	0.0 (Cancel), 0.1 to 500.0 Hz	N	Y	0.0	Y	Y	N	N	N	5-174
H66	(Voltage)	0 to 240V: AVR operation (200V class) 0 to 500V: AVR operation (400V class)	N	Y2	0	Y	Y	N	N	N	
H68	Slip compensation 1 (Operating conditions selection)	0: Enable during acceleration/deceleration, enable at base frequency or higher 1: Disable during acceleration/deceleration, enable at base frequency or higher 2: Enable during acceleration/deceleration, disable at base frequency or higher 3: Disable during acceleration/deceleration, disable at base frequency or higher	N	Y	0	Y	Y	N	N	N	5-174
H69	Anti-regenerative control (Mode selection)	0: Disable 2: Torque limit control with force-to-stop (Cancel limit control after three times of deceleration time has passed) 3: DC link bus voltage control with force-to-stop (Cancel voltage control after three times of deceleration time has passed) 4: Torque limit control without force-to-stop 5: DC link bus voltage control without force-to-stop	Y	Y	0	Y	Y	Y	N	Y	5-175
H70	Overload prevention control	0.00: Follow the deceleration time selected 0.01 to 100.00 Hz/s, 999 (Cancel)	Y	Y	999	Y	Y	Y	N	Y	5-176
H71	Deceleration characteristics	0: Disable 1: Enable	Y	Y	0	Y	Y	Y	N	N	5-176
H72	Main power shutdown detection (Mode selection)	0: Disable 1: Enable (Available VXT-88A-2/VXT-59A-4 or above)	Y	Y	1	Y	Y	Y	Y	Y	5-176
H74	Torque limiter *5 (Control target)	0: Torque limit 1: Torque current limit	N	Y	1	N	N	Y	Y	Y	5-177
H76	Torque limiter (Braking) (Frequency rising limiter for braking)	0.0 to 500.0Hz	Y	Y	5.0	Y	Y	N	N	N	5-177
H77	Service life of DC link bus capacitor	0 to 8760 (in units of ten hours)	Y	N	6132 (ND spec)	Y	Y	Y	Y	Y	5-177

5.2 Function Codes Table

Code	Name	Data setting range	Change when running	Data copying	Factory Default	Drive control					Related page
						V/f	PG V/f	w/ PG	Torque control	PM	
	(Remaining time)										

*5: Available at ROM version 0300 or later.

*10: 6.00s for inverters of nominal applied motor 22kW or below; 20.0s for those of 30kW or above.

Code	Name	Data setting range	Change when running	Data copying	Factory Default	Drive control					Related page
						V/f	PG V/f	w/ PG	Torque control	PM	
H78	Maintenance interval (M1)	0 (Disable): 1 to 9999 (in units of ten hours)	Y	N	6132 (ND spec)	Y	Y	Y	Y	Y	5-177
H79	Preset startup count for maintenance (M1)	0000 (Disable): 0001 to FFFF (in hexadecimal)	Y	N	0	Y	Y	Y	Y	Y	5-178
H80	Output current fluctuation damping gain for motor 1	0.00 to 1.00	Y	Y	0.20	Y	Y	N	N	N	5-178
H81	Light alarm selection 1	0000 to FFFF (in hexadecimal)	Y	Y	0	Y	Y	Y	Y	Y	5-179
H82	Light alarm selection 2	0000 to FFFF (in hexadecimal)	Y	Y	0	Y	Y	Y	Y	Y	
H84	Pre-excitation *5 (Level)	100 to 400 % (Motor rated magnetizing current for 100%)	Y	Y	100	N	N	Y	Y	N	5-181
H85	(Timer)	0.00; 0.01 to 30.00 s 0.00; Invalid 0.01 to 30.00 s	Y	Y	0.00	N	N	Y	Y	N	
H86	Reserved *9	0 to 2	Y	Y	0	-	-	-	-	-	5-183
H89	Reserved *9	0 to 1	Y	Y	1	-	-	-	-	-	5-183
H90	Reserved *9	0 to 1	Y	Y	0	-	-	-	-	-	5-183
H91	PID feedback wire break detection	0.0 (Alarm disable): 0.1 to 60.0 s	Y	Y	0.0	Y	Y	Y	N	Y	5-183
H92	Continuous running at the momentary power failure (P)	0.000 to 10.000 times; 999 999:Manufacturer adjustment value	Y	Y1 Y2	999	Y	Y	Y	N	Y	5-183
H93	(I)	0.010 to 10.000 s; 999 999:Manufacturer adjustment value	Y	Y1 Y2	999	Y	Y	Y	N	Y	
H94	Cumulative motor run time 1	0 to 9999 Change in cumulative motor run time (Reset is enabled) (in units of 10 hours)	N	N	-	Y	Y	Y	Y	Y	5-177-183
H95	DC braking (Braking response mode)	0: Slow response 1: Quick response	Y	Y	1	Y	Y	N	N	N	5-74 5-183
H96	STOP key priority/ Start check function	0: STOP key priority disable/ Start check function disable 1: STOP key priority enable/ Start check function disable 2: STOP key priority disable/ Start check function enable 3: STOP key priority enable/ Start check function enable	Y	Y	0	Y	Y	Y	Y	Y	5-184
H97	Clear alarm data	0: Disable 1: Alarm data clear (Automatically return to 0 after clearing data)	Y	N	0	Y	Y	Y	Y	Y	5-184
H98	Protection/Maintenance function (Mode selection)	0 to 127 (Data is displayed in decimal) Bit 0: Lower the carrier frequency automatically (0: Disable; 1: Enable) Bit 1: Input phase loss protection (0: Disable; 1: Enable) Bit 2: Output phase loss protection (0: Disable; 1: Enable) Bit 3: Main circuit capacitor life judgment selection (0: Factory default referenced; 1 User measurement value standard) Bit 4: Judge the life of main circuit capacitor (0: Disable; 1: Enable) Bit 5: Detect DC fan lock (0: Enable; 1: Disable) Bit 6: Braking transistor error detection (0: Disable; 1: Enable)	Y	Y	*11	Y	Y	Y	Y	Y	5-185
H99	Password 2 setting/check	0000 to FFFF (Hexadecimal)	Y	N	0	Y	Y	Y	Y	Y	5-187
H101	Destination	0: Not selected 1: Japan 2: Asia 3: China 4: Europe 5: Americas 7: Korea	N	Y	4	Y	Y	Y	Y	Y	5-190
H111	UPS operation level	120 to 220 VDC: (200 V class) 240 to 440 VDC: (400 V class)	Y	Y2	220 440	Y	Y	Y	N	N	5-190
H114	Anti-regenerative control (Level)	0.0 to 50.0%, 999: disabled	Y	Y	999	Y	Y	Y	N	Y	5-190
H147	Speed control (Jogging)	0.00 to 99.99 s	Y*	Y	0.00	N	N	Y	N	N	5-

5.2 Function Codes Table

Code	Name	Data setting range	Change when running	Data copying	Factory Default	Drive control					Related page
						V/f	PG V/f	w/ PG	Torque control	PM	
	FF (Gain) *5										1905-230

Factory Default: set for Europe

*5: Available at ROM version 0300 or later.

*9: Factory use. Do not access these function codes.

*11: VXT-115A-2 or below: 83, VXT-72A-4 or below: 83, VXT-12A-1 or below: 83, VXT-85A-4 or above: 19.

5.2 Function Codes Table

Code	Name	Data setting range	Change when running	Data copying	Factory Default	Drive control					Related page
						V/f	PG V/f	w/ PG	Torque control	PM	
H154	Torque bias (Mode selection) *5	0: Invalid 1: Digital torque bias 2: Analog torque bias	N	Y	0	N	N	Y	N	N	5-190
H155	(Level 1)	-300 to +300 %	N	Y	0	N	N	Y	N	N	
H156	(Level 2)	-300 to +300 %	N	Y	0	N	N	Y	N	N	
H157	(Level 3)	-300 to +300 %	N	Y	0	N	N	Y	N	N	
H158	(Mechanical loss compensation)	0 to 300 %	N	Y	0	N	N	Y	N	N	
H159	(Startup timer)	0.00 to 1.00 s	N	Y	0.00	N	N	Y	N	N	
H161	(Shutdown timer)	0.00 to 1.00 s	N	Y	0.00	N	N	Y	N	N	
H162	(Limiter)	0 to 300 %	N	Y	200	N	N	Y	N	N	
H173	Magnetic flux level at light load *5	10 to 100 %	Y	Y	100	N	N	Y	Y	N	5-192
H180	Brake control signal (Check-timer for brake operation)	0.00 to 10.00 s	Y	Y	0.00	Y	Y	Y	N	N	5-192
H193	User initial value (Save)	0: Disable, 1: Save	Y	N	0	Y	Y	Y	Y	Y	5-156
H194	(Protection)	0: Save enable, 1: Protected (Save disable)	Y	Y	0	Y	Y	Y	Y	Y	
H195	DC braking (Braking timer at the startup)	0.00 (Disable): 0.01 to 30.00 s	Y	Y	0.00	Y	Y	N	N	N	5-74 5-192
H196	Reserved *5 *9	0.001 to 9.999, 999	Y	Y	999	Y	Y	N	N	N	—
H197	User password 1 (Selection of protective operation)	0: All function codes are disclosed, but the change is not allowed. 1: Only the function code for quick setup can be disclosed/changed. 2: Only the function code for customize logic setting is not disclosed/not changed.	Y	Y	0	Y	Y	Y	Y	Y	5-187
H198	(Setting/check)	0000 to FFFF (Hexadecimal)	Y	N	0	Y	Y	Y	Y	Y	
H199	User password protection valid	0: Disable 1: Protected	Y	N	0	Y	Y	Y	Y	Y	

*5: Available at ROM version 0300 or later.

*9: Factory use. Do not access these function codes.

■ A codes: Motor 2 Parameters (Motor 2 parameters)

Code	Name	Data setting range	Change when running	Data copying	Factory Default	Drive control					Related page
						V/f	PG V/f	w/ PG	Torque control	PM	
A01	Maximum output frequency 2	25.0 to 500.0Hz	N	Y	50.0 Hz	Y	Y	Y	Y	N	-
A02	Base frequency 2	25.0 to 500.0Hz	N	Y	50Hz	Y	Y	Y	Y	N	
A03	Rated voltage at base frequency 2	0: AVR disable (output voltage proportional to power voltage) 80 to 240V: AVR operation (200V class) 160 to 500V: AVR operation (400V class)	N	Y2	200V class 200V	Y	Y	Y	Y	N	
A04	Maximum output voltage 2	80 to 240V: AVR operation (200V class) 160 to 500V: AVR operation (400V class)	N	Y2	400V class 400V	Y	Y	N	Y	N	
A05	Torque boost 2	0.0 to 20.0% (% value against base frequency voltage 2)	Y	Y	*2	Y	Y	N	N	N	
A06	Electronic thermal overload protection for motor 2 (Select motor characteristics)	1: Enable (For a general-purpose motor with self-cooling fan) 2: Enable (For an inverter-driven motor with separately powered cooling fan)	Y	Y	1	Y	Y	Y	Y	N	
A07	(Overload detection level)	0.00 (disable), current value of 1 to 135% of inverter rated current	Y	Y1 Y2	*3	Y	Y	Y	Y	N	
A08	(Thermal time constant)	0.5 to 75.0 min	Y	Y	*4	Y	Y	Y	Y	N	
A09	DC braking 2 (Braking starting frequency)	0.0 to 60.0Hz	Y	Y	0.0	Y	Y	Y	N	N	
A10	(Braking level)	0 to 100% (HHD mode), 0 to 80% (HD/HND mode) 0 to 60% (ND mode)	Y	Y	0	Y	Y	Y	N	N	
A11	(Braking time)	0.00 (Disable): 0.01 to 30.00 s	Y	Y	0.00	Y	Y	Y	N	N	
A12	Starting frequency 2	0.0 to 60.0Hz	Y	Y	0.5	Y	Y	Y	N	N	
A13	Load selection / Auto torque boost/ Auto energy-saving operation 2	0: Variable torque load 1: Constant torque load 2: Auto torque boost 3: Auto energy-saving operation (variable torque load) 4: Auto energy-saving operation (constant torque load) 5: Auto energy-saving operation with auto torque boost	N	Y	1	Y	Y	Y	N	N	
A14	Drive control selection 2	0: V/f control without slip compensation 1: Vector control without speed sensor (Dynamic torque vector control) 2: V/f control with slip compensation 3: V/f control with speed sensor 4: V/f control with speed sensor and auto torque boost 6: Vector control for induction motor with speed sensor	N	Y	0	Y	Y	Y	Y	N	
A15	Motor 2 (No. of poles)	2 to 22 poles	N	Y1 Y2	4	Y	Y	Y	Y	N	
A16	(Rated capacity)	0.01 to 1000 kW (At P39 = 0, 4) 0.01 to 1000 HP (At P39 = 1)	N	Y1 Y2	*6	Y	Y	Y	Y	N	
A17	(Rated current)	0.00 to 2000A	N	Y1 Y2	*6	Y	Y	Y	Y	N	
A18	(Auto-tuning)	0: Disable 1: Stop tuning 2: Rotation tuning 5: Stop tuning (%R1, %X)	N	N	0	Y	Y	Y	Y	N	
A19	(Online tuning)	0: Invalid 1:Valid	Y	Y	0	Y	N	N	N	N	
A20	(No-load current)	0.00 to 2000A	N	Y1 Y2	*6	Y	Y	Y	Y	N	
A21	(%R1)	0.00 to 50.00%	Y	Y1 Y2	*6	Y	Y	Y	Y	N	
A22	(%X)	0.00 to 50.00%	Y	Y1 Y2	*6	Y	Y	Y	Y	N	

Factory Default: set for Europe

*2: Factory defaults are depended on motor capacity. Refer to "5.2.3 Factory default value per applicable electric motor capacitance".

*3: The motor rated current is automatically set. Refer to the VXT User's Manual, "5.2.4 Motor constant" (function code P03).

*4: Standard applicable electric motor is 5.0 min for 22 kW or lower and 10.0 min for 30 kW or higher.

*6: Factory defaults are depended on motor capacity. Refer to the VXT User's Manual, "5.2.4 Motor constant".

5.2 Function Codes Table

Code	Name	Data setting range	Change when running	Data copying	Factory Default	Drive control					Related page
						V/f	PG V/f	w/ PG	Torque control	PM	
A23	Motor 2 (Slip compensation gain for driving)	0.0 to 200.0%	Y*	Y	100.0	Y	Y	Y	N	N	
A24	(Slip compensation response time)	0.01 to 10.00 s	Y	Y1 Y2	0.50	Y	Y	N	N	N	
A25	(Slip compensation gain for braking)	0.0 to 200.0%	Y*	Y	100.0	Y	Y	Y	N	N	
A26	(Rated slip frequency)	0.00 to 15.00Hz	N	Y1 Y2	*6	Y	Y	Y	N	N	
A27	(Iron loss factor 1)	0.00 to 20.00%	Y	Y1 Y2	*6	Y	Y	Y	Y	N	
A30	(Magnetic saturation factor 1) *5	0.0 to 300.0 %	Y	Y1 Y2	*6	N	N	Y	Y	N	
A31	(Magnetic saturation factor 2) *5	0.0 to 300.0 %	Y	Y1 Y2	*6	N	N	Y	Y	N	
A32	(Magnetic saturation factor 3) *5	0.0 to 300.0 %	Y	Y1 Y2	*6	N	N	Y	Y	N	
A33	(Magnetic saturation factor 4) *5	0.0 to 300.0 %	Y	Y1 Y2	*6	N	N	Y	Y	N	
A34	(Magnetic saturation factor 5) *5	0.0 to 300.0 %	Y	Y1 Y2	*6	N	N	Y	Y	N	
A39	Motor 2 selection	0: Motor characteristics 0 1: Motor characteristics 1 (HP rating IMs) 4: Other IMs	N	Y1 Y2	0	Y	Y	Y	Y	N	
A40	Slip compensation 2 (Operating conditions selection)	0: Enable during acceleration/deceleration, enable at base frequency or higher 1: Disable during acceleration/deceleration, enable at base frequency or higher 2: Enable during acceleration/deceleration, disable at base frequency or higher 3: Disable during acceleration/deceleration, disable at base frequency or higher	N	Y	0	Y	Y	N	N	N	
A41	Output current fluctuation damping gain for motor 2	0.00 to 1.00	Y	Y	0.20	Y	Y	N	N	N	
A43	Speed control 2 *5 (Speed command filter)	0.000 to 5.000 s	Y	Y	0.020	N	Y	Y	N	Y	5-228
A44	(Speed detection filter)	0.000 to 0.100 s	Y*	Y	0.005	N	Y	Y	N	Y	
A45	P (Gain)	0.1 to 200.0 times	Y*	Y	10.0	N	Y	Y	N	Y	
A46	I (Integral time)	0.001 to 9.999 s; 999 (Cancel integral term)	Y	Y	0.100	N	Y	Y	N	Y	
A47	FF (Gain)	0.00 to 99.99 s	Y	Y	0.00	N	N	Y	N	Y	
A49	(Notch filter resonance frequency)	1 to 200 Hz	Y	Y	200	N	N	Y	N	N	
A50	(Notch filter attenuation level)	0 to 20 dB	Y	Y	0	N	N	Y	N	N	
A51	Cumulative motor run time 2	0 to 9999 Change in cumulative motor run time (Reset is enabled) (in units of 10 hours)	N	N	-	Y	Y	Y	Y	N	-
A52	Startup counter for motor 2	For adjustment at replacement (0000 to FFFF in hexadecimal)	Y	N	-	Y	Y	Y	Y	N	
A53	Motor 2 (%X correction factor 1)	0 to 300%	Y	Y1 Y2	100	Y	Y	Y	Y	N	
A55	(Torque current under vector control) *5	0.00 to 2000 A	N	Y1 Y2	*6	N	N	Y	Y	N	
A56	(Induced voltage factor under vector control) *5	50 to 100 %	N	Y1 Y2	*6	N	N	Y	Y	N	
A98	Motor 2 (Function selection)	0 to 255 (Data is displayed in decimal, Meaning of each bit 0: Disable; 1 Enable) bit0: Current limiter (F43, F44) bit1: Rotational direction control (H08) bit2: Non-linear V/f (H50 to H53, H65, H66) bit3: PID control (J01 to J62, H91) bit4: Brake signal bit5: Braking timer at the Startup (H195) Bit6 to 7: Reserved *9	N	Y	0	Y	Y	Y	Y	Y	5-195

Factory Default: set for Europe

*5: Available at ROM version 0300 or later.

*6: Factory defaults are depended on motor capacity. Refer to the VXT User's Manual, "5.2.4 Motor constant".

*9: Factory use. Do not change these function codes.

■ **b codes: Motor control parameter 3**

Code	Name	Data setting range	Change when running	Data copying	Factory Default	Drive control					Related page
						V/f	PG V/f	w/ PG	Torque control	PM	
b43	Speed control 3 *5 (Speed command filter)	0.000 to 5.000 s	Y	Y	0.020	N	Y	Y	N	Y	5-228
b44	(Speed detection filter)	0.000 to 0.100 s	Y*	Y	0.005	N	Y	Y	N	Y	
b45	P (Gain)	0.1 to 200.0	Y*	Y	10.0	N	Y	Y	N	Y	
b46	I (Integral time)	0.001 to 9.999 s; 999 (Cancel integral term)	Y*	Y	0.100	N	Y	Y	N	Y	
b47	FF (Gain)	0.00 to 99.99	Y*	Y	0.00	N	N	Y	N	Y	
b49	(Notch filter resonance frequency)	1 to 200Hz	Y	Y	200	N	N	Y	N	N	
b50	(Notch filter attenuation level)	0 to 20dB	Y	Y	0	N	N	Y	N	N	

*5: Available at ROM version 0300 or later.

■ **r codes: Motor control parameter 4**

Code	Name	Data setting range	Change when running	Data copying	Factory Default	Drive control					Related page
						V/f	PG V/f	w/ PG	Torque control	PM	
r43	Speed control 4 *5 (Speed command filter)	0.000 to 5.000 s	Y	Y	0.020	N	Y	Y	N	Y	5-228
r44	(Speed detection filter)	0.000 to 0.100 s	Y*	Y	0.005	N	Y	Y	N	Y	
r45	P (Gain)	0.1 to 200.0 times	Y*	Y	10.0	N	Y	Y	N	Y	
r46	I (Integral time)	0.001 to 9.999 s; 999 (Cancel integral term)	Y*	Y	0.100	N	Y	Y	N	Y	
r47	FF (Gain)	0.00 to 99.99	Y*	Y	0.00	N	N	Y	N	Y	
r49	(Notch filter resonance frequency)	1 to 200 Hz	Y	Y	200	N	N	Y	N	N	
r50	(Notch filter attenuation level)	0 to 20 dB	Y	Y	0	N	N	Y	N	N	

*5: Available at ROM version 0300 or later.

■ J codes: Application Functions 1 (Application function 1)

Code	Name	Data setting range	Change when running	Data copying	Factory Default	Drive control					Related page
						V/f	PG V/f	w/ PG	Torque control	PM	
J01	PID control (Mode selection)	0: Disable 1: Process (normal operation) 2: Process (inverse operation) 3: Speed control (Dancer)	N	Y	0	Y	Y	Y	N	Y	5-197
J02	(Remote command)	0: Keypad key operation (↔/↔key) 1: PID process command 1 (Analog input: Terminals 12, C1 and V2) 3: UP/DOWN 4: Communication	N	Y	0	Y	Y	Y	N	Y	5-198
J03	P (Gain)	0.000 to 30.000 times	Y	Y	0.100	Y	Y	Y	N	Y	5-204
J04	I (Integral time)	0.0 to 3600.0 s	Y	Y	0.0	Y	Y	Y	N	Y	
J05	D (Differential time)	0.00 to 600.00 s	Y	Y	0.00	Y	Y	Y	N	Y	
J06	(Feedback filter)	0.0 to 900.0 s *1	Y	Y	0.5	Y	Y	Y	N	Y	
J10	(Anti-reset windup)	0 to 200%	Y	Y	200	Y	Y	Y	N	Y	5-207
J11	(Select Warning output)	0: Warning caused by process command value 1: Warning caused by process command value with hold 2: Warning caused by process command value with latch 3: Warning caused by process command value with hold and latch 4: Warning caused by PID error value 5: Warning caused by PID error value with hold 6: Warning caused by PID error value with latch 7: Warning caused by PID error value with hold and latch	Y	Y	0	Y	Y	Y	N	Y	5-208
J12	(Upper limit of warning (AH))	-100% to 100%	Y	Y	100	Y	Y	Y	N	Y	
J13	(Lower limit of warning (AL))	-100% to 100%	Y	Y	0	Y	Y	Y	N	Y	
J15	(Sleep frequency)	0.0 (Disable): 1.0 to 500.0 Hz	Y	Y	0.0	Y	Y	Y	N	Y	5-210
J16	(Sleep timer)	0 to 60 s	Y	Y	30	Y	Y	Y	N	Y	
J17	(Wakeup frequency)	0.0 to 500.0Hz	Y	Y	0.0	Y	Y	Y	N	Y	
J18	(Upper limit of PID process output)	-150% to 150% ; 999 (Depends on setting of F15)	Y	Y	999	Y	Y	Y	N	Y	5-211
J19	(Lower limit of PID process output)	-150% to 150% ; 999 (Depends on setting of F16)	Y	Y	999	Y	Y	Y	N	Y	
J23	(Wakeup level of PID error)	0.0 to 100.0%	Y	Y	0.0	Y	Y	Y	N	Y	5-210
J24	(Wakeup timer)	0 to 3600 s	Y	Y	0	Y	Y	Y	N	Y	
J57	(Dancer position set point)	-100 to 0 to 100%	Y	Y	0	Y	Y	Y	N	Y	5-211
J58	(Detection width of dancer position error)	0: Disable switching PID constant 1 to 100%: Manually set value	Y	Y	0	Y	Y	Y	N	Y	5-212
J59	P (Gain) 2	0.000 to 30.000 times	Y	Y	0.100	Y	Y	Y	N	Y	
J60	I (Integral time) 2	0.0 to 3600.0 s	Y	Y	0.0	Y	Y	Y	N	Y	
J61	D (Differential time) 2	0.00 to 600.00 s	Y	Y	0.00	Y	Y	Y	N	Y	
J62	(PID control block selection)	0 to 3 bit0: Select polarity compensation for PID output/error 0=Plus (Addition); 1=Minus (Subtraction) bit1: Select compensation factor for PID output 0=Ratio (relative to the main setting) 1=Speed command (relative to maximum frequency)	N	Y	0	Y	Y	Y	N	Y	5-212
J63	Overload stop (Item selection)	0: Torque, 1: Current	Y	Y	0	Y	Y	Y	N	Y	5-213
J64	(Detection level)	20 to 200%	Y	Y	100	Y	Y	Y	N	Y	
J65	(Mode selection)	0: Disable 1: Decelerate to stop 2: Coast to a stop	N	Y	0	Y	Y	Y	N	Y	
J66	(Operation mode)	0: During constant speed running and deceleration 1: During constant speed running 2: Anytime	Y	Y	0	Y	Y	Y	N	Y	
J67	(Timer)	0.00 to 600.00 s	Y	Y	0.00	Y	Y	Y	N	Y	

5.2 Function Codes Table

Code	Name	Data setting range	Change when running	Data copying	Factory Default	Drive control					Related page
						V/f	PG V/f	w/ PG	Torque control	PM	
J68	Brake control signal (Brake-release current)	0.00 to 300.00%	Y	Y	100.0	Y	Y	Y	N	N	5-214
J69	(Brake-release frequency/speed)	0.0 to 25.0 Hz	Y	Y	1.0	Y	Y	N	N	N	
J70	(Brake-release timer)	0.00 to 5.00 s	Y	Y	1.00	Y	Y	Y	N	N	
J71	(Brake-applied frequency/speed)	0.0 to 25.0 Hz	Y	Y	1.0	Y	Y	Y	N	N	
J72	(Brake-applied timer)	0.00 to 5.00 s	Y	Y	1.00	Y	Y	Y	N	N	
J73	Positioning control *5 (Start timer)	0.0 to 1000.0 s	Y	Y	0.0	Y	Y	N	N	N	5-217
J74	(Start point; upper digits)	-999(83E7) to 999(03E7) -999(83E7) to -1(8001) 0(0000) to 999(03E7)	Y	Y	0	Y	Y	N	N	N	
J75	(Start point; lower digits)	0(0000) to 9999(270F) ; P = -1(FFFF)	Y	Y	0	Y	Y	N	N	N	
J76	(Preset point; upper digits)	-999(83E7) to 999(03E7) -999(83E7) to -1(8001) 0(0000) to 999(03E7)	Y	Y	0	Y	Y	N	N	N	
J77	(Preset point; lower digits)	0(0000) to 9999(270F) ; P = -1(FFFF)	Y	Y	0	Y	Y	N	N	N	
J78	(Creep speed SW point; upper digits)	0 to 999	Y	Y	0	Y	Y	N	N	N	
J79	(Creep speed SW point; lower digits)	0 to 9999	Y	Y	0	Y	Y	N	N	N	
J80	(Creep speed)	0 to 500 Hz	Y	Y	0.0	Y	Y	N	N	N	
J81	(End point; upper digits)	-999(83E7) to 999(03E7) -999(83E7) to -1(8001) 0(0000) to 999(03E7)	Y	Y	0	Y	Y	N	N	N	
J82	(End point; lower digits)	0(0000) to 9999(270F)	Y	Y	0	Y	Y	N	N	N	
J83	(Completion range)	0 to 9999	Y	Y	0	Y	Y	N	N	N	
J84	(End timer)	0.0 to 1000.0 s	Y	Y	0.0	Y	Y	N	N	N	
J85	(Coasting compensation)	0 to 9999	Y	Y	0	Y	Y	N	N	N	
J86	(End point: serial pulse input format)	0: Direction and pulse 1: Forward and reverse pulse	Y	Y	0	Y	Y	N	N	N	
J87	(Preset positioning requirement)	0: Allow to preset at the forward rotation only 1: Allow to preset at the reverse rotation only 2: Allow to preset at any rotations	N	Y	0	Y	Y	N	N	N	
J88	(Direction of detected position)	0: Not switch the direction of detected position 1: Switch the direction of detected position	N	Y	0	Y	Y	N	N	N	
J95	Brake control signal *5 (Brake-release torque)	0.00 to 300.00 %	Y	Y	100.00	N	N	Y	N	N	5-214
J96	(Brake-apply conditions)	0 to 31 Bit0: Speed detection / Speed command (0: Speed detection ; 1: Speed command) Bit1: Reserved Bit2: Reserved Bit3: Reserved Bit4: Brake-apply condition (0: Regardless of run command status (ON or OFF) ; 1: Only when run command is OFF.)	Y	Y	0	N	N	Y	N	N	
J97	Servo lock *5 (Gain)	0.000 to 9.999 times	Y*	Y	0.010	N	N	Y	N	N	5-226
J98	(Completion timer)	0.000 to 1.000 s	Y	Y	0.100	N	N	Y	N	N	
J99	(Completion range)	0 to 9999	Y	Y	10	N	N	Y	N	N	

*5: Available at ROM version 0300 or later.

5.2 Function Codes Table

Code	Name	Data setting range	Change when running	Data copying	Factory Default	Drive control					Related page
						V/f	PG V/f	w/ PG	Torque control	PM	
J105	PID control (Display unit)	0 to 80 0: Inherit (PID Control 1 feedback unit) 1: none 2: % 4: r/min 7: kW [Flow] 20: m3/s 21: m3/min 22: m3/h 23: L/s 24: L/min 25: L/h [Pressure] 40: Pa 41: kPa 42: MPa 43: mbar 44: bar 45: mmHg 46: psi PSI (Pounds per square inch absolute) 47: mWG 48: inWG [Temperature] 60: K 61: degreeC 62: degreeF [Concentration] 80: ppm	N	Y	0	Y	Y	Y	N	Y	5-227
J106	(Maximum scale)	-999.00 to 0.00 to 9990.00	N	Y	100	Y	Y	Y	N	Y	
J107	(Minimum scale)	-999.00 to 0.00 to 9990.00	N	Y	0.00	Y	Y	Y	N	Y	
J136	PID multistep command (Multistep command 1)	-999.00 to 0.00 to 9990.00	Y	Y	0.00	Y	Y	Y	N	Y	5-227
J137	(Multistep command 2)	-999.00 to 0.00 to 9990.00	Y	Y	0.00	Y	Y	Y	N	Y	
J138	(Multistep command 3)	-999.00 to 0.00 to 9990.00	Y	Y	0.00	Y	Y	Y	N	Y	

■ d codes: Application Functions 2 (Application function 2)

Code	Name	Data setting range	Change when running	Data copying	Factory Default	Drive control					Related page
						V/f	PG V/f	w/ PG	Torque control	PM	
d01	Speed control 1 *5 (Speed command filter)	0.000 to 5.000 s	Y	Y	0.020	N	Y	Y	N	Y	5-228
d02	(Speed detection filter)	0.000 to 0.100 s	Y*	Y	0.005	N	Y	Y	N	Y	
d03	P (Gain)	0.1 to 200.0 times	Y*	Y	10.0	N	Y	Y	N	Y	
d04	I (Integral time)	0.001 to 9.999 s; 999(Cancel integral term)	Y	Y	0.100	N	Y	Y	N	Y	
d05	FF (Gain)	0.00 to 99.99 s	Y	Y	0.00	N	N	Y	N	Y	
d07	(Notch filter resonance frequency)	1 to 200 Hz	Y	Y	200	N	N	Y	N	N	
d08	(Notch filter attenuation level)	0 to 20dB	Y	Y	0	N	N	Y	N	N	
d09	Speed control (Jogging) *5 (Speed command filter)	0.000 to 5.000 s	Y	Y	0.020	N	Y	Y	N	N	
d10	(Speed detection filter)	0.000 to 0.100 s	Y*	Y	0.005	N	Y	Y	N	N	
d11	P (Gain)	0.1 to 200.0 times	Y*	Y	10.0	N	Y	Y	N	N	
d12	I (Integral time)	0.001 to 9.999 s; 999(Cancel integral term)	Y*	Y	0.100	N	Y	Y	N	N	
d14	Feedback Input *5 (Pulse input format)	0: Frequency and direction 1: Forward and reverse pulse 2: Quadrature A/B signal(B phase lead) 3: Quadrature A/B signal(A phase lead)	N	Y	2	N	Y	Y	Y	N	5-231
d15	(Encoder pulse resolution)	0014 to EA60(Hexadecimal) pulses (20 to 60000 (Decimal) pulses)	N	Y	0400 (1024)	N	Y	Y	Y	N	
d16	(Pulse scaling factor 1)	1 to 9999	N	Y	1	N	Y	Y	Y	N	
d17	(Pulse scaling factor 2)	1 to 9999	N	Y	1	N	Y	Y	Y	N	
d21	Speed agreement / PG error *5 (Hysteresis width)	0.0 to 50.0 %	Y	Y	10.0	N	Y	Y	N	Y	5-233
d22	(Detection timer)	0.00 to 10.00 s	Y	Y	0.50	N	Y	Y	N	Y	
d23	PG error processing *5	0: Continue to run 1 1: Stop with alarm 1 2: Stop with alarm 2 3: Continue to run 2 4: Stop with alarm 3 5: Stop with alarm 4	N	Y	2	N	Y	Y	N	Y	
d24	Zero speed control *5	0: Disable at startup 1: Enable at startup	N	Y	0	N	N	Y	N	N	5-234
d25	ASR switching time *5	0.000 to 1.000 s	Y	Y	0.000	N	Y	Y	Y	Y	5-234
d32	Speed limit / Over speed level 1 *5	0 to 110 %	Y	Y	100	N	N	Y	Y	Y	5-234
d33	Speed limit / Over speed level 2 *5	0 to 110 %	Y	Y	100	N	N	Y	Y	Y	
d35	Over speed detection level *5	0 to 120 %; 999 999: Depend on d32, d33	Y	Y	999	N	Y	Y	Y	Y	5-234
d41	Application specific function selection *5	0: Invalid 1: Line speed control with speed sensor 2: Master-follower operation (Immediate synchronization mode at the start, without Z phase) 3: Master-follower operation (Start after synchronization mode) 4: Master-follower operation (Immediate synchronization mode at the start, with Z phase)	N	Y	0	N	Y	N	N	N	5-234
d51	Reserved *9	-500 to 500	N	Y	*12	Y	Y	Y	Y	Y	5-237
d52	Reserved *9	-500 to 500	N	Y	*12	Y	Y	Y	Y	Y	
d55	Reserved *9	0000 to 00FF (Display in hexadecimal)	N	Y	0	Y	Y	Y	Y	Y	
d59	Command (Pulse train input) *5 (Pulse input format)	0: Frequency and direction 1: Forward and reverse pulse 2: Quadrature A/B signal(B phase lead) 3: Quadrature A/B signal(A phase lead)	N	Y	0	Y	Y	Y	Y	Y	5-244
d60	(Encoder pulse resolution)	0014 to 0E10 (Hexadecimal) pulses (20 to 3600 (Decimal) pulses)	N	Y	0400 (1024)	N	Y	Y	N	N	5-237
d61	(Filter time constant)	0.000 to 5.000 s	Y	Y	0.005	Y	Y	Y	Y	Y	5-237
d62	(Pulse scaling factor 1)	1 to 9999	Y	Y	1	Y	Y	Y	Y	Y	
d63	(Pulse scaling factor 2)	1 to 9999	Y	Y	1	Y	Y	Y	Y	Y	

*5: Available at ROM version 0300 or later.

*9: Factory use. Do not change these function codes.

*12: VXT12A-1 or below: 20, VXT115A-2 or below: 20, VXT290A-4 or below: 20, VXT361A-4 and VXT415A-4□:50, VXT520A-4 or above: 100.

5.2 Function Codes Table

Code	Name	Data setting range	Change when running	Data copying	Factory Default	Drive control					Related page
						V/f	PG V/f	w/ PG	Torque control	PM	
d67	PMSM starting mode *5 (Auto search)	0: Disable 1: Enable (At restart after momentary power failure) 2: Enable (At restart after momentary power failure and at normal start)	N	Y	2	N	N	N	N	Y	5-237
d69	Reserved *9	30.0 to 100.0Hz	Y	Y	30.0	Y	Y	N	N	N	5-237
d70	Speed control limiter *5	0.00 to 100.00 %	Y	Y	100.00	N	Y	N	N	N	5-247
d71	Master follower control *5 (Main speed regulator gain)	0.00 to 1.50 times	Y	Y	1.00	N	Y	Y	N	N	5-238
d72	(APR gain)	0.00 to 200.00 times	Y	Y	15.00	N	Y	Y	N	N	
d73	(APR positive output limiter)	20 to 200 %; 999: Invalid	Y	Y	999	N	Y	Y	N	N	
d74	(APR negative output limiter)	20 to 200 %; 999: Invalid	Y	Y	999	N	Y	Y	N	N	
d75	(Z phase alignment gain)	0.00 to 10.00 times	Y	Y	1.00	N	Y	Y	N	N	
d76	(Offset angle between master and follower)	0 to 359 deg	Y	Y	0	N	Y	Y	N	N	
d77	(Synchronous completion detection angle)	0 to 359 deg	Y	Y	15	N	Y	Y	N	N	
d78	(Excessive error detection level)	0 to 65535 (10 unit pulse)	Y	Y	65535	N	Y	Y	N	N	
d79	Reserved *5 *9	0; 80 to 240 V (200V order) 160 to 500 V (400V order); 999	N	Y2	0	N	N	N	N	Y	5-237
d88	Reserved *5 *9	0.00 to 100.00 %, 999	Y	Y	999	N	N	N	N	Y	
d90	Magnetic flux level during deceleration under vector control *5	100 to 300 %	Y	Y	150	N	N	Y	N	N	5-247
d91	Reserved *9	0.00 to 2.00, 999	Y	Y	999	-	-	-	-	-	5-237
d92	Reserved *5 *9	0.00 to 10.00	Y	Y	0.30	-	-	-	-	-	
d93	Reserved *5 *9	0.00 to 10.00; 999	Y	Y	999	N	N	N	N	Y	
d94	Reserved *5 *9	0.00 to 10.00; 999	Y	Y	999	N	N	N	N	Y	
d95	Reserved *5 *9	0.00 to 10.00; 999	Y	Y	999	N	N	N	N	Y	
d96	Reserved *5 *9	-50.0 to 50.0; 999	Y	Y	999	N	N	N	N	Y	
d97	Reserved *5 *9	-50.0 to 50.0; 999	Y	Y	999	N	N	N	N	Y	
d99	Extension function 1	0 to 127 Bit 0-2: Reserved *9 Bit 3: JOG operation from communication (0: Disable; 1: Enable) Bit 4-8: Reserved *9	Y	Y	0	-	-	-	-	-	5-247

*5: Available at ROM version 0300 or later.

*9: Factory use. Do not change these function codes.

■ U codes: Application Functions 3 (Customizable logic)

Code	Name	Data setting range	Change when running	Data copying	Factory Default	Drive control					Related page
						V/f	PG V/f	w/ PG	Torque control	PM	
U00	Customizable logic (Mode selection)	0: Disable 1: Enable (Customizable logic operation) ECL alarm occurs when the value is changed from 1 to 0 during operation.	Y	Y	0	Y	Y	Y	Y	Y	5-250
U01	Customizable logic: Step 1 (Block selection)	[Digital] 0: No function assigned 10 to 15: Through output + General-purpose timer 20 to 25: Logical AND + General-purpose timer 30 to 35: Logical OR + General-purpose timer 40 to 45: Logical XOR + General-purpose timer 50 to 55: Set priority flip-flop + General-purpose timer 60 to 65: Reset priority flip-flop + General-purpose timer 70, 72, 73: Rising edge detector + General-purpose timer 80, 82, 83: Falling edge detector + General-purpose timer 90, 92, 93: Rising & falling edges detector + General-purpose timer 100 to 105: Hold + General-purpose timer 110: Increment counter 120: Decrement counter 130: Timer with reset input General-purpose timer function (Least significant digit 0 to 5) _0: No timer _1: On-delay timer _2: Off-delay timer _3: Pulse (1 shot) _4: Retriggerable timer _5: Pulse train output [Analog] 2001: Adder 2002: Subtractor 2003: Multiplier 2004: Divider 2005: Limiter 2006: Absolute value of input 2007: Inverting adder 2008: Variable limiter 2009: Linear function 2051 to 2056: Comparator1 to 6 2071, 2072: Window comparator1, 2 2101: High selector 2102: Low selector 2103: Average of inputs 2151: Loading function from S13 2201: Clip and map function 2202: Scale converter 3001: Quadratic function 3002: Square root function [Digital, Analog] 4001: Hold 4002: Inverting adder with enable 4003, 4004: Selector 1, 2 4005: LPF(Low-pass filter) with enable 4006: Rate limiter with enable 5000: Selector 3 5100: Selector 4 6001: Reading function code 6002: Writing function code 6003: Temporary change of function code 6101: PID dancer output gain frequency	N	Y	0	Y	Y	Y	Y	Y	

5.2 Function Codes Table

Code	Name	Data setting range	Change when running	Data copying	Factory Default	Drive control					Related page
						V/f	PG V/f	w/ PG	Torque control	PM	
U02	Customizable logic: Step 1 (Input 1)	[Digital] 0 to 105: The same as E20 value. However, 27, 111 to 120 cannot be selected	N	Y	100	Y	Y	Y	Y	Y	
U03	(Input 2)	2001 to 2200 (3001 to 3200): Output of Step 1 to 200 "SO01" to "SO200" 4001 (5001): X1 terminal input signal "X1" 4002 (5002): X2 terminal input signal "X2" 4003 (5003): X3 terminal input signal "X3" 4004 (5004): X4 terminal input signal "X4" 4005 (5005): X5 terminal input signal "X5" 4010 (5010): FWD terminal input signal "FWD" 4011 (5011): REV terminal input signal "REV" *4021(5021): Digital input I1 (OPC-DIO) *5 *4022(5022): Digital input I2 (OPC-DIO) *5 *4023(5023): Digital input I3 (OPC-DIO) *5 *4024(5024): Digital input I4 (OPC-DIO) *5 *4025(5025): Digital input I5 (OPC-DIO) *5 *4026(5026): Digital input I6 (OPC-DIO) *5 *4027(5027): Digital input I7 (OPC-DIO) *5 *4028(5028): Digital input I8 (OPC-DIO) *5 *4029(5029): Digital input I9 (OPC-DIO) *5 *4030(5030): Digital input I10 (OPC-DIO) *5 *4031(5031): Digital input I11 (OPC-DIO) *5 *4032(5032): Digital input I12 (OPC-DIO) *5 *4033(5033): Digital input I13 (OPC-DIO) *5 6000 (7000): Final run command RUN "FL_RUN" 6001 (7001): Final run command FWD "FL_FWD" 6002 (7002): Final run command REV "FL_REV" 6003 (7003): Accelerating "DACC" 6004 (7004): Decelerating "DDEC" 6005 (7005): Under anti-regenerative control "REGA" 6006 (7006): Within dancer reference position "DR_REF" 6007 (7007): With/without alarm factor "ALM_ACT" * Inside the () is the negative logic signal. (OFF at short-circuit) [Analog] 8000 to 8021: The value with 8000 added to F31 9001: Analog I2 terminal input signal [I2] 9002: Analog C1 terminal input signal [C1] (C1) 9003: Analog V2 terminal input signal [C1] (V2) *9004: Analog I2 terminal input signal [I2] *5 *9005: Analog C2 terminal input signal [C2] *5	N	Y	100	Y	Y	Y	Y	Y	
U04	(Function 1)	-9990 to 0.00 to 9990	N	Y	0.00	Y	Y	Y	Y	Y	
U05	(Function 2)		N	Y	0.00	Y	Y	Y	Y	Y	

*: The use of the option card lets those functions remain in effect.
*5: Available at ROM version 0300 or later.

Customizable logic Step 1 to 14 function code is assigned as follows: Setting value is the same as U01 to U05.

Block selection	Step1	Step2	Step3	Step4	Step5	Step6	Step7	Step8	Step9	Step10
Input 1	U01	U06	U11	U16	U21	U26	U31	U36	U41	U46
Input 2	U02	U07	U12	U17	U22	U27	U32	U37	U42	U47
Function 1	U03	U08	U13	U18	U23	U28	U33	U38	U43	U48
Function 2	U04	U09	U14	U19	U24	U29	U34	U39	U44	U49
	U05	U10	U15	U20	U25	U30	U35	U40	U45	U50
Block selection	Step11	Step12	Step13	Step14						
Input 1	U51	U56	U61	U66						
Input 2	U52	U57	U62	U67						
Function 1	U53	U58	U63	U68						
Function 2	U54	U59	U64	U69						
	U55	U60	U65	U70						

5.2 Function Codes Table

Code	Name	Data setting range	Change when running	Data copying	Factory Default	Drive control					Related page
						V/f	PG V/f	w/ PG	Torque control	PM	
U71	Customizable logic (Output selection) Output signal 1	0: Disable 1 to 200: Output of Step 1 to 200 "S001" to "S0200"	N	Y	0	Y	Y	Y	Y	Y	
U72	Output signal 2		N	Y	0	Y	Y	Y	Y	Y	
U73	Output signal 3		N	Y	0	Y	Y	Y	Y	Y	
U74	Output signal 4		N	Y	0	Y	Y	Y	Y	Y	
U75	Output signal 5		N	Y	0	Y	Y	Y	Y	Y	
U76	Output signal 6		N	Y	0	Y	Y	Y	Y	Y	
U77	Output signal 7		N	Y	0	Y	Y	Y	Y	Y	
U78	Output signal 8		N	Y	0	Y	Y	Y	Y	Y	
U79	Output signal 9		N	Y	0	Y	Y	Y	Y	Y	
U80	Output signal 10		N	Y	0	Y	Y	Y	Y	Y	
U81	Customizable logic (Function selection) Output signal 1	0 to 172 (1000 to 1172): Same as E01 8001 to 8020: The value with 8000 added to E61	N	Y	100	Y	Y	Y	Y	Y	
U82	Output signal 2		N	Y	100	Y	Y	Y	Y	Y	
U83	Output signal 3		N	Y	100	Y	Y	Y	Y	Y	
U84	Output signal 4		N	Y	100	Y	Y	Y	Y	Y	
U85	Output signal 5		N	Y	100	Y	Y	Y	Y	Y	
U86	Output signal 6		N	Y	100	Y	Y	Y	Y	Y	
U87	Output signal 7		N	Y	100	Y	Y	Y	Y	Y	
U88	Output signal 8		N	Y	100	Y	Y	Y	Y	Y	
U89	Output signal 9		N	Y	100	Y	Y	Y	Y	Y	
U90	Output signal 10		N	Y	100	Y	Y	Y	Y	Y	
U91	Customizable logic timer monitor (Step selection)	0: Monitor disable 1 to 200: Step 1 to 200	Y	N	0	Y	Y	Y	Y	Y	
U92	Customizable logic (The coefficients of the approximate formula) (Mantissa of KA1)	-9.999 to 9.999	N	Y	0.000	Y	Y	Y	Y	Y	
U93	(Exponent part of KA1)	-5 to 5	N	Y	0	Y	Y	Y	Y	Y	
U94	(Mantissa of KB1)	-9.999 to 9.999	N	Y	0.000	Y	Y	Y	Y	Y	
U95	(Exponent part of KB1)	-5 to 5	N	Y	0	Y	Y	Y	Y	Y	
U96	(Mantissa of KC1)	-9.999 to 9.999	N	Y	0.000	Y	Y	Y	Y	Y	
U97	(Exponent part KC1)	-5 to 5	N	Y	0	Y	Y	Y	Y	Y	
U100	Task process cycle setting	0: Auto select from 2, 5, 10 or 20 ms depending on the number of steps 2: 2 ms (Up to 10 step) 5: 5 ms (Up to 50 step) 10: 10 ms (Up to 100 step) 20: 20ms (Up to 200 step) *5	N	Y	0	Y	Y	Y	Y	Y	
U101	Customizable logic (Operating point 1 (X1))	-999.00 to 0.00 to 9990.00	Y	Y	0.00	Y	Y	Y	Y	Y	5-250 5-273
U102	(Operating point 1 (Y1))		Y	N		Y	Y	Y	Y	Y	
U103	(Operating point 2 (X2))		Y	N		Y	Y	Y	Y	Y	
U104	(Operating point 2 (Y2))		Y	N		Y	Y	Y	Y	Y	
U105	(Operating point 3 (X3))		Y	N		Y	Y	Y	Y	Y	
U106	(Operating point 3 (Y3))		Y	N		Y	Y	Y	Y	Y	
U107	Customizable logic (Auto calculation of the coefficients of the approximate formula)	0: Invalid 1: Execute calculation (When the calculation is finished, the results are stored to the function code U92 to U97)	N	N	0	Y	Y	Y	Y	Y	5-250 5-274

5.2 Function Codes Table

Code	Name	Data setting range	Change when running	Data copying	Factory Default	Drive control					Related page
						V/f	PG V/f	w/ PG	Torque control	PM	
U121	Customizable logic (User parameter 1)	-9990.00 to 0.00 to 9990.00	Y	Y	0.00	Y	Y	Y	Y	Y	5-250
U122	(User parameter 2)					Y	Y	Y	Y	Y	
U123	(User parameter 3)					Y	Y	Y	Y	Y	
U124	(User parameter 4)					Y	Y	Y	Y	Y	
U125	(User parameter 5)					Y	Y	Y	Y	Y	
U126	(User parameter 6)					Y	Y	Y	Y	Y	
U127	(User parameter 7)					Y	Y	Y	Y	Y	
U128	(User parameter 8)					Y	Y	Y	Y	Y	
U129	(User parameter 9)					Y	Y	Y	Y	Y	
U130	(User parameter 10)					Y	Y	Y	Y	Y	
U131	(User parameter 11)					Y	Y	Y	Y	Y	
U132	(User parameter 12)					Y	Y	Y	Y	Y	
U133	(User parameter 13)					Y	Y	Y	Y	Y	
U134	(User parameter 14)					Y	Y	Y	Y	Y	
U135	(User parameter 15)					Y	Y	Y	Y	Y	
U136	(User parameter 16)					Y	Y	Y	Y	Y	
U137	(User parameter 17)					Y	Y	Y	Y	Y	
U138	(User parameter 18)					Y	Y	Y	Y	Y	
U139	(User parameter 19)					Y	Y	Y	Y	Y	
U140	(User parameter 20)					Y	Y	Y	Y	Y	
U171	Customizable logic (Storage area 1)	-9990.00 to 0.00 to 9990.00	Y	Y	0.00	Y	Y	Y	Y	Y	
U172	(Storage area 2)					Y	Y	Y	Y	Y	
U173	(Storage area 3)					Y	Y	Y	Y	Y	
U174	(Storage area 4)*5					Y	Y	Y	Y	Y	
U175	(Storage area 5)*5					Y	Y	Y	Y	Y	
U190	Customizable logic setting step (Step number)	1 to 200	Y	Y	15	Y	Y	Y	Y	Y	
U191	Setting step (Select block)	Same as U01	N	Y	0	Y	Y	Y	Y	Y	
U192	(Input 1)	Same as U02	N	Y	100	Y	Y	Y	Y	Y	
U193	(Input 2)	Same as U03	N	Y	100	Y	Y	Y	Y	Y	
U194	(Function 1)	Same as U04	N	Y	0.00	Y	Y	Y	Y	Y	
U195	(Function 2)	Same as U05	N	Y	0.00	Y	Y	Y	Y	Y	
U196	Customizable logic ROM version Upper digit (Monitor)	0 to 9999	N	N	0	Y	Y	Y	Y	Y	
U197	Customizable logic ROM version Upper digit (For User setting)	0 to 9999	N	Y	0	Y	Y	Y	Y	Y	
U198	Customizable logic ROM version Lower digit (Monitor)	0 to 9999	N	N	0	Y	Y	Y	Y	Y	
U199	Customizable logic ROM version Lower digit (For User setting)	0 to 9999	N	Y	0	Y	Y	Y	Y	Y	

*5: Available at ROM version 0300 or later.

■ y codes: LINK Functions (Link function)

Code	Name	Data setting range	Change when running	Data copying	Factory Default	Drive control					Related page
						V/f	PG V/f	w/ PG	Torque control	PM	
y01	RS-485 Communication 1 (Station address)	1 to 255	N	Y	1	Y	Y	Y	Y	Y	5-277
y02	(Communications error processing)	0: Immediately trip with alarm <i>erβ</i> 1: Trip with alarm <i>erβ</i> after running for the period specified by timer y03 2: Retry during the period specified by timer y03. If the retry fails, trip with alarm <i>erβ</i> . If it succeeds, continue to run. 3: Continue to run	Y	Y	0	Y	Y	Y	Y	Y	
y03	(Timer)	0.0 to 60.0 s	Y	Y	2.0	Y	Y	Y	Y	Y	
y04	(Baud rate)	0: 2400 bps 1: 4800 bps 2: 9600 bps 3: 19200 bps 4: 38400 bps	Y	Y	3	Y	Y	Y	Y	Y	
y05	(Data length selection)	0: 8 bit 1: 7 bits	Y	Y	0	Y	Y	Y	Y	Y	
y06	(Parity selection)	0: None (Stop bit: 2 bits) 1: Even number parity (Stop bit: 1 bits) 2: Odd number parity (Stop bit: 1 bits) 3: None (Stop bit: 1 bits)	Y	Y	0	Y	Y	Y	Y	Y	
y07	(Stop bit selection)	0: 2 bits 1: 1 bits	Y	Y	0	Y	Y	Y	Y	Y	
y08	(Communication time-out detection timer)	0: Not check of the time-out 1 to 60 s	Y	Y	0	Y	Y	Y	Y	Y	
y09	(Response interval time)	0.00 to 1.00 s	Y	Y	0.01	Y	Y	Y	Y	Y	
y10	(Protocol selection)	0: Modbus RTU protocol 1: IMO Loader protocol (SX protocol) 2: IMO general-purpose inverter protocol	Y	Y	1	Y	Y	Y	Y	Y	
y11	RS-485 Communication 2 (Station address)	1 to 255	N	Y	1	Y	Y	Y	Y	Y	
y12	(Communications error processing)	0: Immediately trip with alarm <i>erp</i> 1: Trip with alarm <i>erp</i> after running for the period specified by timer y13 2: Retry during the period specified by timer y13. If the retry fails, trip with alarm <i>erp</i> . If it succeeds, continue to run. 3: Continue to run	Y	Y	0	Y	Y	Y	Y	Y	
y13	(Timer)	0.0 to 60.0 s	Y	Y	2.0	Y	Y	Y	Y	Y	
y14	(Baud rate)	0: 2400 bps 1: 4800 bps 2: 9600 bps 3: 19200 bps 4: 38400 bps	Y	Y	3	Y	Y	Y	Y	Y	
y15	(Data length selection)	0: 8 bits 1: 7 bits	Y	Y	0	Y	Y	Y	Y	Y	
y16	(Parity selection)	0: None (Stop bit: 2 bits) 1: Even number parity (Stop bit: 1 bits) 2: Odd number parity (Stop bit: 1 bits) 3: None (Stop bit: 1 bits)	Y	Y	0	Y	Y	Y	Y	Y	
y17	(Stop bit selection)	0: 2 bits 1: 1 bit	Y	Y	0	Y	Y	Y	Y	Y	
y18	(Communication time-out detection timer)	0: Not check of the time-out 1 to 60 s	Y	Y	0	Y	Y	Y	Y	Y	
y19	(Response interval time)	0.00 to 1.00 s	Y	Y	0.01	Y	Y	Y	Y	Y	
y20	(Protocol selection)	0: Modbus RTU protocol 1: IMO Loader protocol (SX protocol) 2: IMO general-purpose inverter protocol	Y	Y	0	Y	Y	Y	Y	Y	

5.2 Function Codes Table

Code	Name	Data setting range	Change when running	Data copying	Factory Default	Drive control					Related page
						V/f	PG V/f	w/ PG	Torque control	PM	
y21	Built-in CAN communication (Node ID)	1 to 127	N	Y	1	Y	Y	Y	Y	Y	5-280
y24	(Baud rate)	0: 125kbps 1: 20kbit/s 2: 50kbit/s 3: 125kbit/s 4: 250kbit/s 5: 500kbit/s 6: 800kbit/s 7: 1Mbit/s	N	Y	0	Y	Y	Y	Y	Y	
y25	Map the inverter function code1 to RPDO No. 3	0000 to FFFF (in hexadecimal) Data mapped I/O (Write)	N	Y	0000	Y	Y	Y	Y	Y	
y26	Map the inverter function code2 to RPDO No. 3					Y	Y	Y	Y	Y	
y27	Map the inverter function code3 to RPDO No. 3					Y	Y	Y	Y	Y	
y28	Map the inverter function code4 to RPDO No. 3					Y	Y	Y	Y	Y	
y29	Map the inverter function code1 to TPDO No. 3					Y	Y	Y	Y	Y	
y30	Map the inverter function code2 to TPDO No. 3					Y	Y	Y	Y	Y	
y31	Map the inverter function code3 to TPDO No. 3					Y	Y	Y	Y	Y	
y32	Map the inverter function code4 to TPDO No. 3					Y	Y	Y	Y	Y	
y33	(Operation selection)	0: Disable, 1: Enable	Y	Y	0	Y	Y	Y	Y	Y	
y34	(Communications error processing)	This function code is valid in case of y36=-4 or -5. 1: After the time specified by [y35], coast to a stop and trip with [ert]. 2: If the inverter receives any data within the time specified by [y35], ignore the communications error. After the timeout, coast to a stop and trip with [ert]. 10: Immediately decelerate to a stop. Issue [ert] after stopping. 11: After the time specified by [y35], decelerate to a stop. Issue [ert] after stopping. 12: If the inverter receives any data within the time specified by [y35], ignore the communications error. After the timeout, decelerate to a stop and trip with [ert]. Otherwise: Immediately coast to a stop and trip with [ert].	Y	Y	0	Y	Y	Y	Y	Y	
y35	(Communication time-out detection timer)	0.0 to 60.0	Y	Y	0.0	Y	Y	Y	Y	Y	
y36	(Operation selection in abort status) *5	-5 to 3	Y	Y	1	Y	Y	Y	Y	Y	
y95	Data clear processing for communications error	0: Do not clear the data of function codes Sxx when a communications error occurs. (compatible with the conventional inverters) 1: Clear the data of function codes S01/S05/S19 when a communications error occurs. 2: Clear the run command assigned bit of function code S06 when a communications error occurs. 3: Clear both data of S01/S05/S19 and run command assigned bit of S06 when a communications error occurs. * Related alarms: <i>er8, erp, er4, er5, ert</i>	Y	Y	0	Y	Y	Y	Y	Y	5-280
y97	Communication data storage selection	0: Store into nonvolatile memory (Rewritable times are limited) 1: Write into temporary memory (Rewritable times are unlimited) 2: Save all data from temporary memory to nonvolatile memory (After all save, return to Data 1)	Y	Y	0	Y	Y	Y	Y	Y	5-280
y98	Bus link function (Mode selection)	Frequency command Run command 0: Follow H30 Follow H30 1: Bus link Follow H30 2: Follow H30 Bus link 3: Bus link Bus link	Y	Y	0	Y	Y	Y	Y	Y	5-280
y99	Loader link function (Mode selection)	Frequency command Run command 0: Follow H30, y98 Follow H30, y98 1: Jaguar loader Follow H30, y98 2: Follow H30, y98 Jaguar loader 3: Jaguar loader Jaguar loader	Y	N	0	Y	Y	Y	Y	Y	5-281

*5: Available at ROM version 0300 or later.

■ K codes: Keypad functions for VXT-KP-LED

Code	Name	Data setting range	Change when running	Data copying	Factory Default	Drive control				Related page	
						V/f	PG V/f	w/ PG	Torque control		PM
K01	Multifunction keypad (Language selection)	0: Japanese 1: English 2: German 3: French 4: Spanish 5: Italian 6: Chinese 8: Russian 9: Greek 10: Turkish 11: Polish 12: Czech 13: Swedish 14: Portuguese 15: Dutch 16: Malay 17: Vietnamese 18: Thai 19: Indonesian 100: User-Customizable language	Y	Y	1	Y	Y	Y	Y	Y	-
K02	(Backlight OFF time)	0: Always OFF 1 to 30 min	Y	Y	5	Y	Y	Y	Y	Y	-
K03	(Backlight brightness adjustment)	0 (dark) - 10 (bright)	Y	Y	5	Y	Y	Y	Y	Y	-
K04	(Contrast adjustment)	0 (low) - 10 (high)	Y	Y	5	Y	Y	Y	Y	Y	-
K08	(LCD monitor status display)	0: Not displayed 1: Fully displayed	Y	Y	1	Y	Y	Y	Y	Y	-
K15	(Sub-monitor display selection)	0: Operation guide display 1: Bar graph display	Y	Y	0	Y	Y	Y	Y	Y	-
K16	(Sub-monitor 1 display selection)	1 to 35 1: Output frequency 1 (before slip compensation) 2: Output frequency 2 (after slip compensation)	Y	Y	13	Y	Y	Y	Y	Y	-
K17	(Sub-monitor 2 display selection)	3: Reference frequency 4: Motor rotation speed 5: Load rotation speed 6: Line speed 7: Transport time for specified length 8: Speed (%) 13: Output current 14: Output voltage 18: Calculated torque 19: Input power 25: Load factor 26: Motor output 27: Analog input monitor 31: Current position pulse 32: Position error pulse 33: Torque current (%) 34: Magnetic flux command (%) 35: Input watt-hour	Y	Y	19	Y	Y	Y	Y	Y	-
K20	(Bar graph 1 display selection)	1: Output frequency 1 (before slip compensation) 13: Output current 14: Output voltage	Y	Y	1	Y	Y	Y	Y	Y	-
K21	(Bar graph 2 display selection)	18: Calculated torque 19: Input power	Y	Y	13	Y	Y	Y	Y	Y	-
K22	(Bar graph 3 display selection)	25: Load factor 26: Motor output	Y	Y	19	Y	Y	Y	Y	Y	-
K91	(< key shortcut selection)	0: disabled	Y	Y	0	Y	Y	Y	Y	Y	-
K92	(> key shortcut selection)	11 to 99: respective mode	Y	Y	64	Y	Y	Y	Y	Y	-

The keypad function K codes are used when the multi-function keypad is connected. For details about the K codes, refer to the instruction manual for the keypad.

5.2.3 Factory default value per applicable electric motor capacitance

Applicable electric motor capacity		Torque boost 1 to 2 F09/ A05	
kW	HP		
0.4	1/2	3.5	Restart mode after momentary power failure (Restart timer) H13
0.75	1	6.5	
1.5	2	4.9	
2.2	3	4.5	
3.7	5	4.1	
5.5	7.5	3.4	
7.5	10	2.7	
11	15	2.1	
15	20	1.6	
18.5	25	1.3	1.0
22	30	1.1	
30	40	0.0	
37	50		
45	60		
55	75	0.0	1.5
75	100		
90	125		
110	150		
132	175		2.0
160	200		
200	250		2.5
220	300		
280	400		
315	450		4.0
355	500		

Chapter 6 TROUBLESHOOTING

6.1 Protective Function

In order to prevent system down or to shorten a downtime, Jaguar VXT is provided with various protective functions shown in Table 6.1-1 below. The protective functions marked with an asterisk (*) in the table are disabled by factory default. Enable them according to your needs.

The protective functions include, for example, the “heavy alarm” detection function which, upon detection of an abnormal state, displays the alarm code on the LED monitor and causes the inverter to trip, the “light alarm” detection function which displays the alarm code but lets the inverter continue the current operation, and other warning signal output functions.

If any problem arises, understand the protective functions listed below and follow the procedures given in Sections 6.2 and onwards for troubleshooting.

Table 6.1-1 Abnormal States Detectable (“Heavy Alarm” and “Light Alarm” Objects)

Protective function	Description	Related function code
“Heavy alarm” detection	This function detects an abnormal state, displays the corresponding alarm code, and causes the inverter to trip. See “Table 6.3-1 Various failure detections (Heavy failure objects)” for alarm codes. For details of each alarm code, see the corresponding item in the troubleshooting in the Jaguar VXT User’s Manual, Section 6.3 . The inverter retains the last four alarm codes and their factors together with their running information applied when the alarm occurred, so it can display them.	H98
“Light alarm” detection*	This function detects an abnormal state categorized as a “light alarm,” displays <i>l-a/</i> and lets the inverter continue the current operation without tripping. Details of light alarms are selectable. Selectable details (codes) are shown in “Table 6.3-1 Various failure detections (Heavy failure objects).” See the Jaguar VXT User’s Manual, Section 6.4 for the confirming method and releasing method of the light alarms.	H81 H82
Stall prevention	When the output current exceeds the current limiter level (F44) during acceleration/ deceleration or constant speed running, this function decreases the output frequency to avoid an overcurrent trip.	F44
Overload prevention control*	Before the inverter trips due to a cooling fin overheat (<i>Oh1</i>) or inverter overload (<i>Olu</i>), this function decreases the output frequency of the inverter to reduce the load.	H70
Anti-regenerative control*	If regenerative energy returned exceeds the inverter’s braking capability, this function automatically increases the deceleration time or controls the output frequency to avoid an overvoltage trip.	H69
Deceleration characteristics* (Improvement of braking performance)	During deceleration, this function increases the motor energy loss and decreases the regenerative energy returned to avoid an overvoltage trip (<i>Ou</i>).	H71
Reference loss detection*	This function detects a frequency reference loss (due to a broken wire, etc.), issues the alarm, and continues the inverter operation at the specified frequency.	E65
Automatic lowering of carrier frequency	Before the inverter trips due to an abnormal surrounding temperature or output current, this function automatically lowers the carrier frequency to avoid a trip.	H98
Motor overload early warning*	When the inverter output current has exceeded the specified level, this function issues the “Motor overload early warning” signal before the thermal overload protection function causes the inverter to trip for motor protection (Only for the 1st motor).	E34 E35
Retry*	When the inverter has stopped because of a trip, this function allows the inverter to automatically reset and restart itself. The number of retries and the latency between stop and reset can be specified.	H04 H05
Forced stop*	Upon receipt of the “Force to stop” terminal command STOP, this function interrupts the run and other commands currently applied in order to forcedly decelerate the inverter to a stop state.	H56
Surge protection	This function protects the inverter from a surge voltage between main circuit power lines and the ground.	-
Momentary power failure protection*	<ul style="list-style-type: none"> If a momentary power failure for 15 ms or longer occurs, a protective operation (inverter stop) is activated. When momentary power failure restart is selected, the inverter restarts automatically after voltage restoration within a set-up time (momentary power failure permissible time). 	F14

6.2 Before Proceeding with Troubleshooting

WARNING

- If any of the protective functions has been activated, first remove the cause. Then, after checking that all run commands are set to OFF, release the alarm. If the alarm is released while any run command is set to ON, the inverter may supply the power to the motor, running the motor.

Injury may occur.

- Even though the inverter has interrupted power to the motor, if the voltage is applied to the main circuit input terminals L1/R, L2/S, L3/T, L1/L and L2/N, voltage may be output to inverter output terminals U, V, and W.
- Turn OFF the power and wait for at least five minutes for inverters with a capacity of VX-T11A-1 / VXT-115A-2 / VXT-72A-4 or below, or at least ten minutes for inverters with a capacity of VXT-85A-4 or above. Make sure that the LED monitor or charging lamp are turned OFF. Further, make sure, using a multi-meter or a similar instrument, that the DC intermediate circuit voltage between the terminals P (+) and N (-) has dropped to the safe level (+25 VDC or below).

Electric shock may occur.

6.3 If an Alarm Code Appears on the LED Monitor

6.3.1 Alarm code list

When an alarm is detected, check the alarm code displayed on 7-segment LED of keypad.

When one alarm code has more than one cause, alarm subcodes are provided to make it easy to identify the cause. When there is only one cause, the alarm subcode is displayed as “-” and described as “-.”

* See the Jaguar VXT User's Manual, Chapter 3 “3.4.6 Reading alarm information” for the method of checking the alarm codes.

* With regard to alarm details having alarm sub codes name “For manufacturer”, inform the alarm sub codes, to IMO.

Table 6.3-1 Various failure detections (Heavy failure objects)

Alarm code	Alarm code name	Heavy failure object	Light alarm selectable	Retry object	Alarm subcode*	Alarm subcode name	Reference page
<i>cof</i>	PID feedback wire break	Y	Y	—	—	—	6-7
<i>dba</i>	Braking transistor broken	Y	—	—	—	—	6-7
<i>dbh</i>	Braking resistor overheat (VXT-115A-2 or below /VXT-11A-1 or below /VXT-72A-4 or below)	Y	Y	Y	0	DB resistor overheat	6-7
					1	For manufacturer	
<i>ecf</i>	EN circuit failure	Y	—	—	10	ASIC alarm for functional safety	6-8
					3000	Erroneous detection of STO input	
					Other than above	For manufacturer	
<i>ecl</i>	Customizable logic failure	Y	—	—	—	—	—
<i>ef</i>	Ground fault (VXT-85A-4 or above)	Y	—	—	—	—	6-8
<i>er1</i>	Memory error	Y	—	—	1 to 16	For manufacturer	6-8
<i>er2</i>	Keypad communications error	Y	—	—	1 to 2	For manufacturer	6-9
<i>er3</i>	CPU error	Y	—	—	1 to 9000	For manufacturer	6-9
<i>er4</i>	Option communications error	Y	Y	—	1	For manufacturer	6-9
<i>er5</i>	Option error	Y	Y	—	0	Time-out	6-9
					1 to 10	For manufacturer	
<i>er6</i>	Operation error	Y	—	—	1	STOP key priority/forced stop (STOP terminal)	6-10
					2	Start check function	
					3	Start check function (when operation is permitted)	
					4	Start check function (when reset is turned on)	
					5	Start check function (when the power recovers in powering on)	
					6	Start check function (TP connection)	
					8 to 14	For manufacturer	

6.3 If an Alarm Code Appears on the LED Monitor

Continuation of Table 6.3-1

Alarm code	Alarm code name	Heavy failure object	Light alarm selectable	Retry object	Alarm subcode*	Alarm subcode name	Reference page
<i>er7</i>	Tuning error	Y	—	—	7	Operation command OFF during motor tuning	6-10
					8	Forced stop during motor tuning	
					9	BX command during motor tuning	
					10	Hardware current limit during motor tuning	
					11	Occurrence of low voltage (LV) during motor tuning	
					12	Failure due to prevention of reverse rotation during motor tuning	
					13	Over upper limit frequency during motor tuning	
					14	Switching to commercial power during motor tuning	
					15	Occurrence of alarm during motor tuning	
					16	Change of run command source during motor tuning	
					18	Over acceleration time during motor tuning	
					24	EN terminal failure during motor tuning	
					5000 to 5065	Refer to Chapter 4 “4.8.2 Alarm Information”	
					Other than above	For manufacturer	
<i>er8</i>	RS-485 communications error (Communication port 1)	Y	Y	—	—	—	6-11
<i>erd</i>	Step-out detection	Y	—	—	5001 to 5008	For manufacturer	6-12
<i>ere</i>	Speed inconsistency/ excessive speed deviation	Y	Y	—	1	Signs of speed command and speed detection are inconsistent.	6-13
					3	In the case of excessive speed deviation ($ \text{detected speed} > \text{speed command} $)	
					5	Detected speed remains 0Hz irrespective of speed command.	
					7	In the case of excessive speed deviation ($ \text{detected speed} < \text{speed command} $)	
<i>erf</i>	Data saving error during undervoltage	Y	—	—	—	—	6-14
<i>erh</i>	Hardware error	Y	—	—	—	—	6-14
<i>ero</i>	Positioning control error	Y	Y	—	1 to 5	For manufacturer	6-14
<i>erp</i>	RS-485 communications error (Communication port 2)	Y	Y	—	—	—	6-12
<i>err</i>	Simulated failure	Y	—	—	—	—	6-15
<i>ert</i>	CAN communications failure	Y	—	—	1 to 2	For manufacturer	6-15
<i>fUs</i>	DC fuse-blowing	Y	—	—	—	—	6-15
<i>lin</i>	Input phase loss	Y	—	—	1-2	For manufacturer	6-16
<i>lu</i>	Undervoltage	Y	—	—	1	Occurrence of low voltage during gate ON (F14=0)	6-16
					2	Run command ON during low voltage (F14=0, 2)	
					3	LV trip on power recovery from a momentary power failure (F14=1)	
					4 to 5	For manufacturer	

6.3 If an Alarm Code Appears on the LED Monitor

Continuation of Table 6.3-1

Alarm code	Alarm code name	Heavy failure object	Light alarm selectable	Retry object	Alarm subcode*	Alarm subcode name	Reference page
<i>0c1</i>	Instantaneous overcurrent	Y	—	Y	1 to 5001	For manufacturer	6-17
<i>0c2</i>							
<i>0c3</i>							
<i>0h1</i>	Cooling fin overheat	Y	Y	Y	6	Detection of fan stop	6-18
					Other than above	For manufacturer	
<i>0h2</i>	External alarm	Y	Y	—	—	—	6-18
<i>0h3</i>	Inverter internal overheat	Y	Y	Y	0	Internal air overheat	6-18
					1	Charging resistor overheat	
					Other than above	For manufacturer	
<i>0h4</i>	Motor protection (PTC thermistor)	Y	—	Y	—	—	6-19
<i>0h6</i>	Charging resistor overheat	Y	Y	Y	—	—	6-19
<i>0l1</i>	Motor 1 overload	Y	Y	Y	—	—	6-20
<i>0l2</i>	Motor 2 overload	Y	Y	Y	—	—	
<i>0lu</i>	Inverter overload	Y	—	Y	1	IGBT protection	6-21
					2	Inverter overload	
					10	For manufacturer	
<i>0pl</i>	Output phase-failure detection	Y	—	—	1 to 10	For manufacturer	6-21
<i>0s</i>	Overspeed protection	Y	—	—	—	—	6-22
<i>0u1</i>	Overvoltage	Y	—	Y	1 to 12	For manufacturer	6-22
<i>0u2</i>							
<i>0u3</i>							
<i>pbf</i>	Charger circuit fault (VXT-203A-4 or above)	Y	—	—	1 to 2	For manufacturer	6-23
<i>pg</i>	PG wire break	Y	—	—	10 to 20	For manufacturer	6-23
<i>cnT</i>	Inverter life (Number of startups)	—	Y	—	—	—	6-24
<i>fal</i>	Detect DC fan lock	—	Y	—	—	—	
<i>lif</i>	Lifetime alarm	—	Y	—	—	—	
<i>0h</i>	Cooling fin overheat early warning	—	Y	—	—	—	
<i>0l</i>	Overload early warning	—	Y	—	—	—	
<i>pid</i>	PID alarm output	—	Y	—	—	—	
<i>pTc</i>	PTC thermistor activated	—	Y	—	—	—	
<i>ref</i>	Reference command loss detected	—	Y	—	—	—	
<i>rTe</i>	Machine life (Cumulative motor running hours)	—	Y	—	—	—	
<i>uTl</i>	Low torque detection	—	Y	—	—	—	

- NB) • If a control power supply voltage drops to such a level that the operation of the inverter control circuit cannot be maintained, all protective functions are automatically reset.
- By OFF → ON operation of  key or X terminal (assigned to RST) the protection stop state can be released. In a state that an alarm cause is not removed, however, resetting operation is not effective.
 - If two or more alarms are occurring, the resetting operation remains ineffective until all the alarm causes



6.3 If an Alarm Code Appears on the LED Monitor

- are removed. Alarm factors not removed can be checked from the keypad.
- When assigned to light alarms, "30A/B/C" do not work.

See page shows the page of the user's manual.

Chapter 7 MAINTENANCE AND INSPECTION

Perform daily and periodic inspections to avoid trouble and keep reliable operation of the inverter for a long time. When performing inspections, follow the instructions given in this chapter.

 WARNING 
<ul style="list-style-type: none"> • Before proceeding to the maintenance/inspection jobs, turn OFF the power and wait at least five minutes for inverters VXT-115A-2 / VXT-72A-4 / VXT-11A-1 or below, or at least ten minutes for inverters VXT-85A-4 or above. Make sure that the LED monitor / charging lamp are turned OFF. Further, make sure, using a multi-meter or a similar instrument, that the DC link bus voltage between the terminals P(+) and N(-) has dropped to the safe level (+25 VDC or below). <p>Electric shock may occur.</p> <ul style="list-style-type: none"> • Maintenance, inspection, and parts replacement should be made only by authorized persons. • Take off the watch, rings and other metallic objects before starting work. • Use insulated tools. • Never modify the inverter. <p>Electric shock or injuries could occur.</p>

7.1 Inspection Interval

Table 7.1-1 lists the inspection intervals and check items, as a guide.

Table 7.1-1 List of Inspections

Inspection type	Inspection interval	Check items
Daily inspection	Every day	See Section 7.2 .
Periodic inspection	Every year	See Section 7.3 .
Decennial inspection *1	Every 10 years *2	Replacement of cooling fans *3 Replacement of DC link bus capacitors and close checks

*1 The decennial inspection (except replacement of cooling fans) should be performed only by the persons who authorised by IMO. Contact IMO for further information.

*2 Every 7 years for ND-mode inverters.

*3 For the standard replacement interval of cooling fans, refer to “0

 **Note** The replacement intervals are based on the inverter’s service life estimated at an ambient temperature of 40°C at 100% (HHD-mode inverters) or 80% (ND-/HD-/HND-mode inverters) of full load. In environments with an ambient temperature above 40°C or a large amount of dust or dirt, the replacement intervals may be shorter.

Standard replacement intervals mentioned above are only a guide for replacement, not a guaranteed service life.”

7.2 Daily Inspection

Visually inspect the inverter for operation errors from the outside without removing the covers when the inverter is running or the power is ON.

Table 7.2-1 lists daily inspection items.

Table 7.2-1 Daily Inspection List

Check part	Check item	How to inspect	Evaluation criteria
Environment	1) Check the surrounding temperature, humidity, vibration and atmosphere (dust, gas, oil mist, or water drops). 2) Check that tools or other foreign materials or dangerous objects are not left around the equipment.	1) Check visually or measure using apparatus. 2) Visual inspection	1) The usage environment given in Chapter 1, Section 1.3.1 must be satisfied. 2) No foreign or dangerous objects are left.
External appearance and others	1) Check that the bolts securing the wires to the main circuit terminals and control circuit terminals are not loose <u>before turning the power ON.</u> 2) Check for traces of overheat, discoloration and other defects. 3) Check for abnormal noise, odor, or excessive vibration.	1) Retighten <u>before turning the power ON.</u> 2) Visual inspection 3) Auditory, visual, and olfactory inspection	1) No loose screws. If loose, retighten the screws. 2), 3) No abnormalities
Cooling fans	Check for abnormal noise or excessive vibration when the cooling fans are in operation.	Auditory and visual inspections	No abnormalities
Keypad	Check for alarm indication.	Visual inspection	If any alarm is displayed, refer to Chapter 6.
Performance	Check that the inverter provides the expected performance (as defined in the standard specifications).	Check the monitor items shown on the keypad.	No abnormalities in the output speed, current and voltage and other running data.

7.3 Periodic Inspection

7.3.1 Periodic inspection 1--Before the inverter is powered ON or after it stops running

Perform periodic inspections according to the items listed in Table 7.3-1. Before performing periodic inspection 1, shut down the power and then remove the front cover.

Even if the power has been shut down, it takes the time for the DC link bus capacitor to discharge. After the charging lamp is turned OFF, therefore, make sure that the DC link bus voltage has dropped to the safe level (+25 VDC or below) using a multi-meter or a similar instrument.

Table 7.3-1 Periodic Inspection List 1

Check part	Check item	How to inspect	Evaluation criteria	
Structure such as frame and cover	Check for: 1) Loose bolts (at clamp sections). 2) Deformation and breakage 3) Discoloration caused by overheat 4) Contamination and accumulation of dust or dirt	1) Retighten. 2), 3), 4) Visual inspection	1), 2), 3), 4) No abnormalities (If any section is stained, clean it with a soft cloth.)	
Main circuit	Common	1) Check that bolts and screws are tight and not missing. 2) Check the devices and insulators for deformation, cracks, breakage and discoloration caused by overheat or deterioration. 3) Check for contamination or accumulation of dust or dirt.	1) Retighten. 2), 3) Visual inspection	1), 2), 3) No abnormalities (If any section is stained, clean it with a soft cloth.)
	Conductors and wires	1) Check conductors for discoloration and distortion caused by overheat. 2) Check the sheath of the wires for cracks and discoloration.	1), 2) Visual inspection	1), 2) No abnormalities
	Terminal blocks	Check that the terminal blocks are not damaged.	Visual inspection	No abnormalities
	DC link bus capacitor	1) Check for electrolyte leakage, discoloration, cracks and swelling of the casing. 2) Check that the safety valve does not protrude remarkably.	1), 2) Visual inspection	1), 2) No abnormalities
	Braking resistor	1) Check for abnormal odor or cracks in insulators caused by overheat. 2) Check for wire breakage.	1) Olfactory and visual inspection 2) Check the wires visually, or disconnect either one of the wires and measure the conductivity with a multi-meter.	1) No abnormalities 2) Within $\pm 10\%$ of the resistance of the braking resistor
Control circuit	Printed circuit board	1) Check for loose screws and connectors. 2) Check for odor and discoloration. 3) Check for cracks, breakage, deformation and remarkable rust. 4) Check the capacitors for electrolyte leaks and deformation.	1) Retighten. 2) Olfactory and visual inspection 3), 4) Visual inspection * Judgment on service life using "Menu #5 Maintenance Information" in the VXT User manual	1), 2), 3), 4) No abnormalities
Cooling system	Cooling fan	1) Check for engagement or abnormal vibration. 2) Check for loose bolts. 3) Check for discoloration caused by overheat.	1) Turn by hand. (Be sure to turn the power OFF beforehand.) 2) Retighten. 3) Visual inspection * Judgment on service life using "Menu #5 Maintenance Information" in the VXT User manual	1) Smooth rotation 2), 3) No abnormalities
	Ventilation path	Check the heat sink, intake and exhaust ports for clogging and foreign materials.	Visual inspection	No clogging or accumulation of dust, dirt or foreign materials. Clean it, if any, with a vacuum cleaner.

7.3.2 Periodic inspection 2--When the inverter is ON or it is running

Visually inspect the inverter for operation errors from the outside without removing the covers when the inverter is ON or it is running.

Perform periodic inspections according to the items listed in Table 7.3-2

Table 7.3-2 Periodic Inspection List 2

Check part	Check item	How to inspect	Evaluation criteria	
Input voltage	Check that the input voltages of the main and control circuits are correct.	Measure the input voltages using a multi-meter or the like.	The standard specifications must be satisfied.	
Structure such as chassis and covers	Check for abnormal noise or excessive vibration when the inverter is running.	Visual and auditory inspections	No abnormalities	
Main circuit	Transformers and reactors	Check for abnormal roaring noise or odor when the inverter is running.	Auditory, visual, and olfactory inspections	No abnormalities
	Magnetic contactors and relays	Check for chatters when the inverter is running.	Auditory inspection	No abnormalities
	DC link bus capacitor	Measure the capacitance if necessary.	Judgment on service life using "Menu #5 Maintenance Information (%che)" in the VXT User manual	Capacitance \geq Initial value x 0.85
Cooling fans	Check for abnormal noise or excessive vibration when the inverter is running.	Visual and auditory inspections	No abnormalities	

Additional notes

- (1) The inspection interval (every year) of check items given in Table 7.3-1 and Table 7.3-2 is merely a guide. Make the interval shorter depending on the usage environment.
- (2) Store and organize the inspection results to utilize them as a guide for operation and maintenance of the equipment and service life estimation.
- (3) At the time of an inspection, check the cumulative run times on the keypad to utilize them as a guide for replacement of parts. Refer to "7.4.1 Judgment on service life".
- (4) The inverter has cooling fans inside to ventilate itself for discharging the heat generated by the power converter section. This will accumulate dust or dirt on the heat sink depending on the ambient environment. In a dusty environment, the heat sink requires cleaning in a shorter interval than that specified in periodic inspection. Neglecting cleaning of the heat sink can rise its temperature, activating protective circuits to lead to an abrupt shutdown or causing the temperature rise of the surrounding electronic devices to adversely affect their service life.

7.4 List of Periodic Replacement Parts

Each part of the inverter has its own service life that will vary according to the environmental and operating conditions. It is recommended that the following parts be replaced at the specified intervals.

When the replacement is necessary, consult IMO.

Table 7.4-1 Replacement Parts

Part name	Standard replacement intervals (See Note below.)
DC link bus capacitor	10 years (7 years in the ND mode)
Electrolytic capacitors on printed circuit boards	10 years (7 years in the ND mode)
Cooling fans	10 years (7 years in the ND mode)
Fuses	10 years (7 years in the ND mode)

Note. These replacement intervals are based on the inverter's service life estimated at a surrounding temperature

of 40°C at 100% (HHD-mode inverters) or 80% (ND-/HD-/HND-mode inverters) of full load. In environments with an ambient temperature above 40°C or a large amount of dust or dirt, the replacement intervals may be shorter. The condition for inverters of VXT-20A-2 / VXT-12A-4 / VXT-11A-1 or below capacity models is a load ratio of 80% even for HHD-mode.

Notes for periodic replacement of parts

- (1) The replacement intervals listed above are a guide for almost preventing parts from failure if those parts are replaced with new ones at the intervals. They do not guarantee the completely fault-free operation.
- (2) Table 7.4-1 does not apply to unused spare parts being kept in storage.
It applies only when they are stored under the temporary and long-term storage conditions given in Chapter 1 "1.3.2 Storage environment" and energized approximately once a year.
- (3) Cooling fans can be replaced by users. Other components can be replaced only by IMO authorised personnel. For the purchase of spare cooling fans, contact IMO.

7.4.1 Judgment on service life

The inverter has the life prediction function for some parts which measures the discharging time or counts the voltage applied time, etc. The function allows you to monitor the current lifetime state on the LED monitor and judge whether those parts are approaching the end of their service life.

The life prediction function can also issue early warning signals if the life time alarm command **LIFE** is assigned to any of the digital output terminals. Refer to the VXT User manual Reading maintenance information "Maintenance Information: %che".

Table 7.4-2 lists the parts whose service life can be predicted and details the life prediction function. The predicted values should be used only as a guide since the actual service life is influenced by the ambient temperature and other usage environments.

Table 7.4-2 Life Prediction

Object of life prediction	Prediction function	End-of-life criteria	Prediction timing	"5: MAINTENANCE" on the LED monitor
DC link bus capacitor	<u>Measurement of discharging time</u> Measures the discharging time of the DC link bus capacitor when the main power is shut down and calculates the capacitance.	85% or lower of the initial capacitance at shipment	At periodic inspection (H98: Bit 3 = 0)	5_05 (Capacity)
		85% or lower of the reference capacitance under ordinary operating conditions at the user site	During ordinary operation (H98: Bit 3 = 1)	5_05 (Capacity)
	<u>ON-time counting</u> Counts the time elapsed when the voltage is applied to the DC link bus capacitor, while correcting it according to the capacitance measured above.	Exceeding 87,600 hours (10 years)	During ordinary operation	5_26 (Elapsed time) 5_27 (Time remaining before the end of life)
Electrolytic capacitors on printed circuit boards	Counts the time elapsed when the voltage is applied to the capacitors, while correcting it according to the surrounding temperature.	Exceeding 87,600 hours (10 years)	During ordinary operation	5_06 (Cumulative run time)
Cooling fans	Counts the run time of the cooling fans.	Exceeding 87,600 hours (10 years)	During ordinary operation	5_07 (Cumulative run time)

The service life of the DC link bus capacitor can be judged by the "Measurement of discharging time of the DC link bus capacitor" or "ON-time counting of DC link bus capacitor."

Measurement of discharging time of the DC link bus capacitor

- The discharging time of the DC link bus capacitor depends largely on the inverter's internal load conditions, e.g. options attached or ON/OFF status of digital I/O signals. If actual load conditions are so different from the ones at which the initial/reference capacitance is measured that the measurement result falls out of the accuracy level required, then the inverter does not measure.
When the inverter is connected with a converter or with another inverter via DC common connection, it does not perform any measurement.
- The capacitance measuring conditions at shipment are drastically restricted, e.g., all input terminals being OFF in order to stabilize the load and measure the capacitance accurately. Those conditions are, therefore, different from the actual operating conditions in almost all cases. If the actual operating conditions are the same as those at shipment, shutting down the inverter power automatically measures the discharging time; however, if they are different, no automatic measurement is performed. To perform it, put those conditions back to the factory default ones and shut down the inverter. Refer to 7.4.1 [1] Measuring the capacitance of DC link bus capacitor in comparison with initial one at shipment on page 7-6.
- To measure the capacitance of the DC link bus capacitor *under ordinary operating conditions* when the power is turned OFF, it is necessary to set up the load conditions for ordinary operation and measure the reference capacitance (initial setting) when the inverter is introduced. For the reference capacitance setup procedure, see [2] on page 7-7. Performing the setup procedure automatically detects and saves the measuring conditions of the DC link bus capacitor.
Setting bit 3 of H98 data at "0" restores the inverter to the measurement in comparison with the initial capacitance measured at shipment.



When the inverter uses an auxiliary control power input, the load conditions widely differ so that the discharging time cannot be accurately measured. In this case, measuring of the discharging time can be disabled with the function code H98 (Bit 4 = 0) for preventing unintended measuring.

ON-time counting of DC link bus capacitor

- In a machine system where the inverter main power is rarely shut down, the inverter does not measure the discharging time. For this case, the ON-time counting is provided. The ON-time counting result can be represented as "elapsed time" (5_26) and "time remaining before the end of life" (5_27) as shown in the "DC link bus capacitor" section in Table 7.4-2.

[1] Measuring the capacitance of DC link bus capacitor in comparison with initial one at shipment

The measuring procedure given below measures the capacitance of DC link bus capacitor in comparison with initial one at shipment when the power is turned OFF. The measuring result can be displayed on the keypad as a ratio (%) to the initial capacitance.

----- **Capacitance measuring procedure** -----

- 1) To ensure validity in the comparative measurement, put the condition of the inverter back to the state at factory shipment.
 - Remove the option card (if already in use) from the inverter.
 - In case another inverter is connected via the DC link bus to the P(+) and N(-) terminals of the main circuit, disconnect the wires. It is not required to disconnect the DC reactor (optional), if any.
 - Disconnect power wires for the auxiliary input to the control circuit (R0, T0).
 - Mount the keypad.
 - Turn OFF all the digital input signals fed to terminals [FWD], [REV], and [X1] through [X5] of the control circuit.
 - If an external speed command potentiometer is connected to terminal [13], disconnect it.
 - If an external apparatus is attached to terminal [PLC], disconnect it.
 - Ensure that transistor outputs [Y1] and [Y2] and Relay output terminals [30A/B/C] will not be turned ON.
 - Disable the RS-485 communications link and CANopen communications link.
- If negative logic is specified for the transistor output and relay output signals, they are considered ON when the inverter is not running. Specify positive logic for them.
- 2) Turn ON the main circuit power.
 - 3) Confirm that the DC cooling fan is rotating and the inverter is in stopped state. Disable the cooling fan ON/OFF control (H06 = 0).
 - 4) Shut down the main circuit power.
 - 5) The inverter automatically starts the measurement of the capacitance of the DC link bus capacitor.



If “. . . .” does not appear on the LED monitor, the measurement has not started. Check the conditions listed in 1).

- 6) After “. . . .” has disappeared from the LED monitor, turn ON the main circuit power again.
- 7) Select Menu #5 “Maintenance Information” in Programming mode and check the capacitance (%) of the DC link bus capacitor (5_05).

[2] Measuring the capacitance of the DC link bus capacitor under ordinary operating conditions

The inverter automatically measures the capacitance of the DC link bus capacitor under ordinary operating conditions when the power is turned OFF. This measurement requires setting up the load conditions for ordinary operation and measuring the reference capacitance when the inverter is introduced to the practical operation, using the setup procedure given below

----- Reference capacitance setup procedure -----

- 1) Set bit 3 of function code H98 at “1” (User mode) to enable the user to specify the judgment criteria for the service life of the DC link bus capacitor.
- 2) Turn OFF all run commands.
- 3) Make the inverter ready to be turned OFF under ordinary operating conditions.
- 4) Set each of function codes H42 (Capacitance of DC link bus capacitor) and H47 (Initial capacitance of DC link bus capacitor) at “0000.”
- 5) Turn OFF the inverter, and the following operations are automatically performed.

The inverter measures the discharging time of the DC link bus capacitor and saves the result in function code H47 (Initial capacitance of DC link bus capacitor).

The conditions under which the measurement has been conducted will be automatically collected and saved.

- 6) Turn ON the inverter again.

Confirm that H47 (Initial capacitance of DC link bus capacitor) holds right values. Switch to Menu #5 “Maintenance Information” in Programming mode and confirm that the main capacitor capacity is 100% (5_05 = 100%).



If the measurement has failed, “0001” is entered into each of H42 and H47. Remove the cause of the failure and conduct the measurement again.

Hereafter, each time the inverter is turned OFF, it automatically measures the discharging time of the DC link bus capacitor if the above conditions are met. Periodically check the capacitance (%) of the DC link bus capacitor (5_05) with Menu #5 “Maintenance Information” in Programming mode.



The condition given above produces a rather large measurement error. If this mode gives you a lifetime alarm, revert bit 3 of H98 (Main circuit capacitor life judgment selection) to the default setting (Bit 3 = 0) and conduct the measurement under the condition at the time of factory shipment.

[3] Early warning of lifetime alarm

For the components listed in Table 7.4-2, the inverter can issue an early warning of lifetime alarm LIFE at one of the transistor output terminals [Y1] and [Y2] and Relay output terminals [30A/B/C] as soon as any one of the levels specified in Table 7.4-2 has been exceeded.

The early warning signal is also turned ON when a lock condition on the internal air circulation DC fan (provided on VXT-203A-4 or above) has been detected.

7.5 Measurement of Electrical Amounts in Main Circuit

Because the voltage and current of the power supply (input, primary circuit) of the main circuit of the inverter and those of the motor (output, secondary circuit) contain harmonic components, the readings may vary with the type of the meter. Use meters indicated in Table 7.5-1 when measuring main circuit.

The power factor cannot be measured by a commercially available power-factor meter that measures the phase difference between the voltage and current. To obtain the power factor, measure the power, voltage and current on each of the input and output sides and use the following formula.

■ Three-phase input

$$\text{Power factor} = \frac{\text{Electric power (W)}}{\sqrt{3} \times \text{Voltage (V)} \times \text{Current (A)}} \times 100 \%$$

Table 7.5-1 Meters for Measurement of Main Circuit

Item	Input (primary) side			Output (secondary) side			DC link bus voltage (P(+)-N(-))
Waveform	Voltage 		Current 	Voltage 		Current 	
Name of meter	Ammeter AR, AS, AT	Voltmeter VR, VS, VT	Wattmeter WR, WT	Ammeter AU, AV, AW	Voltmeter VU, VV, VW	Wattmeter WU, WW	DC voltmeter V
Type of meter	Moving iron type	Rectifier or moving iron type	Digital AC power meter	Digital AC power meter	Digital AC power meter	Digital AC power meter	Moving coil type
Symbol of meter			—	—	—	—	

NOTE It is not recommended that meters other than a digital AC power meter be used for measuring the output voltage or output current since they may cause larger measurement errors or, in the worst case, they may be damaged.

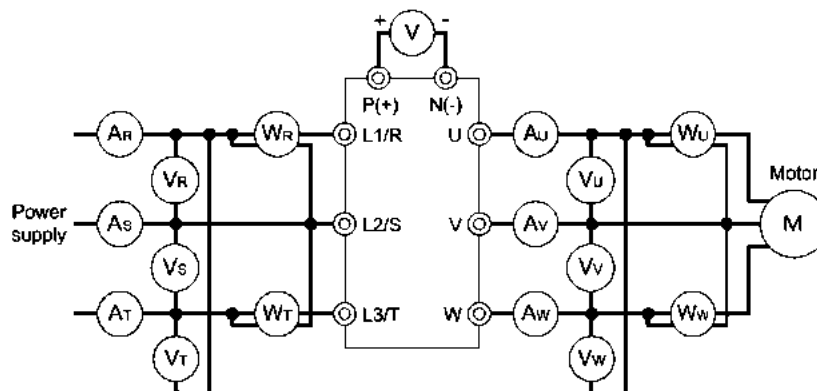

Figure 7.5-1 Connection of Meters

7.6 Insulation Test

Since the inverter has undergone an insulation test before shipment, avoid making a Megger test at the customer's site.

If a Megger test is unavoidable for the main circuit, observe the following instructions; otherwise, the inverter may be damaged.

A withstand voltage test may also damage the inverter if the test procedure is wrong. When the withstand voltage test is necessary, consult IMO.

(1) Megger test of main circuit

- 1) Use a 500 VDC Megger and ensure that the main power has been shut off before measurement.
- 2) If the test voltage leaks to the control circuit due to the wiring, disconnect all the wiring from the control circuit.
- 3) Connect the main circuit terminals with a common line as shown in Figure 7.6-1.
- 4) The Megger test must be limited to across the common line of the main circuit and the ground (⊕).
- 5) Value of 5 MΩ or more displayed on the Megger indicates a correct state. (The value is measured on the inverter alone.)

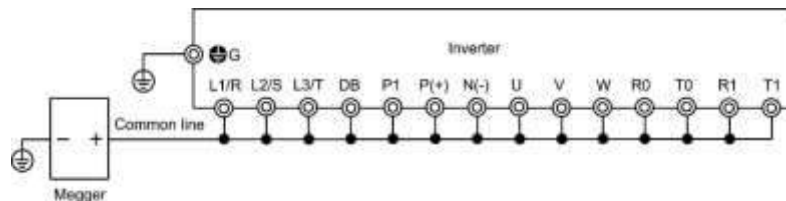

Figure 7.6-1 Main Circuit Terminal Connection for Megger Test

(2) Insulation test of control circuit

Do not make a Megger test or withstand voltage test for the control circuit. Use a high resistance range tester for the control circuit.

- 1) Disconnect all the external wiring from the control circuit terminals.
- 2) Perform a continuity test to the ground. One MΩ or a larger measurement indicates a correct state.

(3) Insulation test of external main circuit and sequence control circuit

Disconnect all the wiring connected to the inverter so that the test voltage is not applied to the inverter.

7.7 Inquiries about Product and Guarantee

7.7.1 When making an inquiry

Upon breakage of the product, uncertainties, failure or inquiries, contact IMO.

- 1) Inverter type. Refer to Chapter 1 "1.1 Acceptance Inspection (Nameplates and Inverter Type)".
- 2) SER No. (serial number of equipment). Refer to Chapter 1 "1.1 Acceptance Inspection (Nameplates and Inverter Type)".
- 3) Function codes and their data that you changed. Refer to the VXT User manual, checking changed function codes "Data Checking: *rep*".
- 4) ROM version. Refer to the maintenance item *5_14* in the VXT User manual, reading maintenance information "Maintenance Information: *%che*".
- 5) Date of purchase
- 6) Inquiries (for example, point and extent of breakage, uncertainties, failure phenomena, and other circumstances)

7.7.2 Product warranty

To all our customers who purchase IMO Jaguar inverters included in this documentation:

Please take the following items into consideration when placing your order.

When requesting an estimate and placing your orders for the products included in these materials, please be aware that any items such as specifications which are not specifically mentioned in the contract, catalogue, specifications or other materials will be as mentioned below.

In addition, the products included in these materials are limited in the use they are put to and the place where they can be used, etc., and may require periodic inspection. Please confirm these points with your sales representative or directly with this IMO.

Furthermore, regarding purchased products and delivered products, we request that you take adequate consideration of the necessity of rapid receiving inspections and of product management and maintenance even before receiving your products.

[1] Warranty period and warranty range

IMO Jaguar inverter 5 year warranty
<p>. Terms of IMO 5 year warranty.</p> <ul style="list-style-type: none"> • IMO Jaguar Inverters are covered by a 5 year warranty from date of dispatch. • In the event of failure due to faulty components or inferior workmanship, the Inverter will be replaced or repaired free Warranty replacements and repaired units will be dispatched free of charge, all costs related to faulty units being returned to IMO for inspection/repair are the responsibility of the sender. • In circumstances where it is viable for the Inverter to be repaired in situ due to size (>30kw), an Engineer from IMO or contracted to represent IMO can be supplied. Site visits are chargeable at IMO's current service rate, any warranty parts will be replaced free of charge. • All Inverters require a Returns Authorization reference to be supplied with the Inverter upon returning the drive to IMO, this reference can be obtained from our website www.imopconline.com by registering and following the returns instructions. <p>Warranty restrictions.</p> <ul style="list-style-type: none"> • Incorrect, or unsafe installation. • Poor condition due to abuse, neglect or improper maintenance. • Modifications, repairs performed by anyone other than IMO or without prior written agreement. • Inverter used in incorrect application or used for function other than for which it is designed. • Any alterations, which may invalidate the Inverters CE declaration. • Non IMO options or ancillary devices used. <p>Liability.</p> <ul style="list-style-type: none"> • Regardless whether a breakdown occurs during or after the warranty period, IMO shall not be liable for any loss of opportunity, loss of profits, penalty clauses or damages arising from any special circumstances, secondary damages, accident compensation to another company, damages to any equipment, or personal injury.

(3) Fault diagnosis

As a rule, the customer is requested to carry out a preliminary fault diagnosis. However, at the customer's request, IMO can perform the fault diagnosis on a chargeable basis. In this case, the customer is asked to accept the charges levied in accordance with IMO'S fee schedule.

[2] Exclusion of liability for loss of opportunity, etc.

Regardless of whether a breakdown occurs during or after the free of charge warranty period, IMO shall not be liable for any loss of opportunity, loss of profits, or damages arising from special circumstances, secondary damages, accident compensation to another company, or damages to products other than IMO'S products, whether foreseen or not by IMO, which IMO is not be responsible for causing.

[3] Repair period after production stop, spare parts supply period (holding period)

Concerning models (products) which have gone out of production, IMO can perform repairs for a period of 5 years after production stop, counting from the month and year when the production stop occurs. In addition, we will continue to supply the spare parts required for repairs for a period of 5 years, counting from the month and year when the production stop occurs. However, if it is estimated that the life cycle of certain electronic and other parts is short and it will be difficult to procure or produce those parts, there may be cases where it is difficult to provide repairs or supply spare parts even within this 5-year period. For details, contact IMO.

[4] Transfer rights

In the case of standard products which do not include settings or adjustments in an application program, the products shall be transported to and transferred to the customer and this company shall not be responsible for local adjustments or trial operation.

[5] Service contents

The cost of purchased and delivered products does not include the cost of dispatching engineers or service costs. Depending on the request, these can be discussed separately.

[6] Applicable scope of service

Above contents shall be assumed to apply to transactions and use of the country where you purchased the products. Consult IMO.

Chapter 8 SPECIFICATIONS

This chapter describes the output ratings, input power, basic functions and other specifications of the Jaguar VXT standard and EMC Filter Built-in model.

Contents

8.1	Standard Model	8-2
8.1.1	ND-mode inverters for general load	8-2
8.1.2	HD-mode inverters for heavy duty load	8-5
8.1.3	HND-mode inverters for general load	8-8
8.1.4	HHD-mode inverters for heavy duty load	8-13
8.2	EMC Filter Built-in Type	8-19
8.2.1	ND-mode inverters for general load	8-19
8.2.2	HD-mode inverters for heavy duty load	8-19
8.2.3	HND-mode inverters for general load	8-20
8.2.4	HHD-mode inverters for heavy duty load	8-21
8.3	Common Specifications	8-22

8.1 Standard Model

8.1.1 ND-mode inverters for general load

Standard-model, Three-phase 400 V (460 V) class series (ND-mode: 0.75 kW to 5.5 kW)

Item		Specifications				
Type (VXT-***A-4)		2	4	6	7	12
Nominal applied motor (kW) (Output rating) *1		0.75	1.5	2.2	3.0	5.5
Output ratings	Rated capacity (kVA) *2	1.6 [1.7]	3.1 [3.3]	4.2 [4.4]	5.3 [5.5]	9.1 [9.6]
	Rated voltage (V) *3	Three-phase 380 to 480 V (with AVR function)				
	Rated current (A) *4	2.1	4.1	5.5	6.9	12
	Overload capability	120%-1 min				
Input power	Voltage, frequency	Three-phase 380 to 480 V, 50/60 Hz				
	Allowable voltage/frequency	Voltage: +10 to -15% (Interphase voltage unbalance: 2% or less) *6, Frequency: +5 to -5%				
	Rated input current (w/o DCR) (A) *7	2.7	4.8	7.3	11.3	16.8
	(with DCR) (A)	1.5	2.9	4.2	5.8	10.1
Required capacity (with DCR) (kVA) *8	1.1	2.1	3.0	4.1	7.0	
Braking	Torque (%) *9	53%	50%	48%	29%	27%
	DC braking	Braking starting frequency: 0.0 to 60.0 Hz, Braking time: 0.0 to 30.0 s, Braking level: 0 to 60%				
	Braking transistor	Built-in as standard				
	Minimum resistance value (Ω)	200		160		130
	Braking resistor	Separately mounted option				
DC reactor (DCR)	Separately mounted option					
Applicable safety standards	IEC/EN61800-5-1: 2007					
Enclosure (IEC60529)	IP20, UL open type					
Cooling method	Natural cooling			Fan cooling		
Weight / Mass (kg)	1.2	1.5	1.5	1.6	1.9	

*1 4-pole standard motor

*2 Rated capacity is calculated assuming the rated output voltage as 440 V (460 V).

*3 Output voltage cannot exceed the power supply voltage.

*4 Setting the carrier frequency (F26) to the following value or above requires current derating.

ND spec. of all types : 4 kHz

If the ambient temperature is 40°C (104°F) or above, derating of 2%/°C (2%/1.8°F) relative to the rated current given in this manual is required. For details, refer to Chapter 10 "10.4.2 Guideline for selecting inverter drive mode and capacity."

*6
$$\text{Voltage unbalance}(\%) = \frac{\text{Max. voltage(V)} - \text{Min. voltage(V)}}{\text{Three-phase average voltage(V)}} \times 67 \quad (\text{IEC 61800-3})$$

If the unbalance ratio is 2% to 3%, use an optional AC reactor (ACR).

*7 This specification is an estimated value to be applied when the power supply capacity is 500 kVA (Inverter capacity × 10 when the capacity exceeds 50 kVA) and the power supply with %X = 5% is connected.

*8 This specification applies when a DC reactor (DCR) is used.

*9 Average braking torque for the motor running alone. It depends on the efficiency of the motor.

Standard-model, Three-phase 400 V (460 V) class series (ND-mode: 11 kW to 55 kW)

Item		Specifications							
Type (VXT-***A-4)		22	29	37	44	59	72	85	105
Nominal applied motor (kW) (Output rating) *1		11	15	18.5	22	30	37	45	55
Output ratings	Rated capacity (kVA) *2	16 [17]	22 [23]	28 [29]	34 [35]	45 [47]	55 [57]	65 [68]	80 [84]
	Rated voltage (V) *3	Three-phase 380 to 480 V (with AVR function)							
	Rated current (A) *4	21.5	28.5	37.0	44.0	59.0	72.0	85.0	105
	Overload capability	120%-1 min							
Input power	Voltage, frequency	Three-phase 380 to 480 V, 50/60 Hz							
	Allowable voltage/frequency	Voltage: +10 to -15% (Interphase voltage unbalance: 2% or less) *6, Frequency: +5 to -5%							
	Rated input current (w/o DCR) (A) *7	33.0	43.8	52.3	60.6	77.9	94.3	114	140
	(with DCR) (A)	21.1	28.8	35.5	42.2	57.0	68.5	83.2	102
Required capacity (with DCR) (kVA) *8	15	20	25	29	39	47	58	71	
Braking	Torque (%) *9	12%						5% to 9%	
	DC braking	Braking starting frequency: 0.0 to 60.0 Hz, Braking time: 0.0 to 30.0 s, Braking level: 0 to 60%							
	Braking transistor	Built-in as standard						Separately mounted option	
	Minimum resistance value (Ω)	80	60	40	34.4	16		-	-
	Braking resistor	Separately mounted option							
DC reactor (DCR)	Separately mounted option								
Applicable safety standards	IEC/EN61800-5-1: 2007								
Enclosure (IEC60529)	IP20, UL open type						IP00, UL open type		
Cooling method	Fan cooling								
Weight / Mass (kg)	5.0	5.0	8.0	9.0	9.5	10	2	26	

*1 4-pole standard motor

*2 Rated capacity is calculated assuming the rated output voltage as 440 V (460 V).

*3 Output voltage cannot exceed the power supply voltage.

*4 Setting the carrier frequency (F26) to the following value or above requires current derating.

ND spec. of all types: 4 kHz

If the ambient temperature is 40°C (104°F) or above, derating of 2%/°C (2%/1.8°F) relative to the rated current given in this manual is required. For details, refer to Figure 10.4-1 in Chapter 10 "10.4.2 Guideline for selecting inverter drive mode and capacity."

*6
$$\text{Voltage unbalance}(\%) = \frac{\text{Max. voltage(V)} - \text{Min. voltage(V)}}{\text{Three-phase average voltage(V)}} \times 67 \quad (\text{IEC 61800-3})$$

If the unbalance ratio is 2% to 3%, use an optional AC reactor (ACR).

*7 This specification is an estimated value to be applied when the power supply capacity is 500 kVA (Inverter capacity × 10 when the capacity exceeds 50 kVA) and the power supply with %X = 5% is connected. When applying with motors of 75 kW or above, a DC reactor (DCR) should be used.

*8 This specification applies when a DC reactor (DCR) is used.

*9 Average braking torque for the motor running alone. It depends on the efficiency of the motor.

Standard-model, Three-phase 400 V (460 V) class series (ND-mode: 75 kW to 315 kW)

Item		Specifications									
Type (VXT-***A-4)		139	168	203	240	290	361	415	520	590	
Nominal applied motor (kW) (Output rating)	*1	75	90	110	132	160	200	220	280	315	
Output ratings	Rated capacity (kVA)	*2	106 [111]	128 [134]	155 [162]	183 [191]	221 [231]	275 [288]	316 [331]	396 [414]	450 [470]
	Rated voltage (V)	*3	Three-phase 380 to 480 V (with AVR function)								
	Rated current (A)	*4	139	168	203	240	290	361	415	520	590
	Overload capability		120%-1 min								
Input power	Voltage, frequency		Three-phase 380 to 480 V, 50/60 Hz		Three-phase 380 to 440 V, 50 Hz Three-phase 380 to 480 V, 60 Hz *5						
	Allowable voltage/frequency		Voltage: +10 to -15% (Interphase voltage unbalance: 2% or less) *6 , Frequency: +5 to -5%								
	Rated input current (w/o DCR) (A)	*7	–	–	–	–	–	–	–	–	–
	(with DCR) (A)		138	164	201	238	286	357	390	500	559
Required capacity (with DCR) (kVA)	*8	96	114	139	165	199	248	271	347	388	
Braking	Torque (%)	*9	5% to 9%								
	DC braking		Braking starting frequency: 0.0 to 60.0 Hz, Braking time: 0.0 to 30.0 s, Braking level: 0 to 60%								
	Braking transistor		Separately mounted option								
	Minimum resistance value (Ω)		–								
	Braking resistor		Separately mounted option								
DC reactor (DCR)		Must be used. Separately mounted component. *11									
Applicable safety standards		IEC/EN61800-5-1: 2007									
Enclosure (IEC60529)		IP00, UL open type									
Cooling method		Fan cooling									
Weight / Mass (kg)		30	33	40	62	63	95	96	130	140	

*1 4-pole standard motor

*2 Rated capacity is calculated assuming the rated output voltage as 440 V (460 V).

*3 Output voltage cannot exceed the power supply voltage.

*4 Setting the carrier frequency (F26) to the following value or above requires current derating.
ND spec. of all types : 4 kHz

If the ambient temperature is 40°C (104°F) or above, derating of 2%/°C (2%/1.8°F) relative to the rated current given in this manual is required. For details, refer to Figure 10.4-1 in Chapter 10 "10.4.2 Guideline for selecting inverter drive mode and capacity."

*5 Inverters of VXT-203-4 or above (400 V class series) are equipped with a power switching connector. Use the connector depending upon the applied voltage. For details, refer to Chapter 2 "2.2.7 Switching Connector."

*6
$$\text{Voltage unbalance}(\%) = \frac{\text{Max. voltage(V)} - \text{Min. voltage(V)}}{\text{Three-phase average voltage(V)}} \times 67 \quad (\text{IEC 61800-3})$$

If the unbalance ratio is 2% to 3%, use an optional AC reactor (ACR).

*7 This specification is an estimated value to be applied when the power supply capacity is 500 kVA (Inverter capacity × 10 when the capacity exceeds 50 kVA) and the power supply with %X = 5% is connected. When applying with motors of 75 kW or above, a DC reactor (DCR) should be used.

*8 This specification applies when a DC reactor (DCR) is used.

*9 Average braking torque for the motor running alone. It depends on the efficiency of the motor.

*11 Please consult IMO for details.

8.1.2 HD-mode inverters for heavy duty load

Standard-model, Three-phase 400 V (460 V) class series (HD-mode: 0.75 kW to 5.5 kW)

Item		Specifications				
Type (VXT-***A-4)		2	4	6	7	12
Nominal applied motor (kW) (Output rating)	*1	0.75	1.1	2.2	3.0	5.5
Output ratings	Rated capacity (kVA)	*2 1.4 [1.4]	2.6 [2.7]	3.8 [4.0]	4.8 [5.0]	8.5 [8.8]
	Rated voltage (V)	*3 Three-phase 380 to 480 V (with AVR function)				
	Rated current (A)	*4 1.8	3.4	5.0	6.3	11.1
	Overload capability	150%-1 min				
Input power	Voltage, frequency	Three-phase 380 to 480 V, 50/60 Hz				
	Allowable voltage/frequency	Voltage: +10 to -15% (Interphase voltage unbalance: 2% or less) *6, Frequency: +5 to -5%				
	Rated input current (w/o DCR) (A)	*7 2.7	3.9	7.3	11.3	16.8
	(with DCR) (A)	1.5	2.1	4.2	5.8	10.1
Required capacity (with DCR) (kVA)	*8 1.1	1.5	3.0	4.1	7.0	
Braking	Torque (%)	*9 53%	68%	48%	29%	27%
	DC braking	Braking starting frequency: 0.0 to 60.0 Hz, Braking time: 0.0 to 30.0 s, Braking level: 0 to 80%				
	Braking transistor	Built-in as standard				
	Minimum resistance value (Ω)	200		160		130
	Braking resistor	Separately mounted option				
DC reactor (DCR)	Separately mounted option					
Applicable safety standards	IEC/EN61800-5-1: 2007					
Enclosure (IEC60529)	IP20, UL open type					
Cooling method	Natural cooling			Fan cooling		
Weight / Mass (kg)		1.2	1.5	1.5	1.6	1.9

*1 4-pole standard motor

*2 Rated capacity is calculated assuming the rated output voltage as 440 V (460 V).

*3 Output voltage cannot exceed the power supply voltage.

*4 Setting the carrier frequency (F26) to the following value or above requires current derating.
HD spec. of all types : 4 kHz

If the ambient temperature is 40°C (104°F) or above, derating of 2%/°C (2%/1.8°F) relative to the rated current given in this manual is required. For details, refer to Figure 10.4-1 in Chapter 10 "10.4.2 Guideline for selecting inverter drive mode and capacity."

*6
$$\text{Voltage unbalance}(\%) = \frac{\text{Max. voltage}(\text{V}) - \text{Min. voltage}(\text{V})}{\text{Three-phase average voltage}(\text{V})} \times 67 \quad (\text{IEC 61800-3})$$

If the unbalance ratio is 2% to 3%, use an optional AC reactor (ACR).

*7 This specification is an estimate to be applied when the power supply capacity is 500 kVA (Inverter capacity × 10 when the capacity exceeds 50 kVA) and the power supply with %X = 5% is connected. When applying with motors of 75 kW or above, a DC reactor (DCR) should be used.

*8 This specification applies when a DC reactor (DCR) is used.

*9 Average braking torque for the motor running alone. It depends on the efficiency of the motor.

Standard-model, Three-phase 400 V (460 V) class series (HD-mode: 7.5 kW to 45 kW)

Item		Specifications							
Type (VXT-***A-4)		22	29	37	44	59	72	85	105
Nominal applied motor (kW) (Output rating) *1		7.5	11	15	18.5	22	30	37	45
Output ratings	Rated capacity (kVA) *2	13 [14]	18 [18]	24 [25]	29 [30]	34 [36]	46 [48]	57 [60]	69 [73]
	Rated voltage (V) *3	Three-phase 380 to 480 V (with AVR function)							
	Rated current (A) *4	17.5	23	31	38	45	60	75	91
	Overload capability	150%-1 min							
Input power	Voltage, frequency	Three-phase 380 to 480 V, 50/60 Hz							
	Allowable voltage/frequency	Voltage: +10 to -15% (Interphase voltage unbalance: 2% or less) *6, Frequency: +5 to -5%							
	Rated input current (w/o DCR) (A) *7	23.2	33.0	43.8	52.3	60.6	77.9	94.3	114
	(with DCR) (A)	14.4	21.1	28.8	35.5	42.2	57.0	68.5	83.2
Required capacity (with DCR) (kVA) *8	10	15	20	25	29	39	47	58	
Braking	Torque (%) *9	15%						7% to 12%	
	DC braking	Braking starting frequency: 0.0 to 60.0 Hz, Braking time: 0.0 to 30.0 s, Braking level: 0 to 80%							
	Braking transistor	Built-in as standard						Separately mounted option	
	Minimum resistance value (Ω)	80	60	40	34.4	16	-	-	
	Braking resistor	Separately mounted option							
DC reactor (DCR)	Separately mounted option								
Applicable safety standards	IEC/EN61800-5-1: 2007								
Enclosure (IEC60529)	IP20, UL open type						IP00, UL open type		
Cooling method	Fan cooling								
Weight / Mass (kg)	5.0	5.0	8.0	9.0	9.5	10	25	26	

*1 4-pole standard motor

*2 Rated capacity is calculated assuming the rated output voltage as 440 V (460 V).

*3 Output voltage cannot exceed the power supply voltage.

*4 Setting the carrier frequency (F26) to the following value or above requires current derating.

HD spec. of all types : 4 kHz

If the ambient temperature is 40°C (104°F) or above, derating of 2%/°C (2%/1.8°F) relative to the rated current given in this manual is required. For details, refer to Figure 10.4-1 in Chapter 10 "10.4.2 Guideline for selecting inverter drive mode and capacity."

*6
$$\text{Voltage unbalance}(\%) = \frac{\text{Max. voltage}(V) - \text{Min. voltage}(V)}{\text{Three-phase average voltage}(V)} \times 67 \quad (\text{IEC 61800-3})$$

If the unbalance ratio is 2% to 3%, use an optional AC reactor (ACR).

*7 This specification is an estimated value to be applied when the power supply capacity is 500 kVA (Inverter capacity × 10 when the capacity exceeds 50 kVA) and the power supply with %X = 5% is connected. When applying with motors of 75 kW or above, a DC reactor (DCR) should be used.

*8 This specification applies when a DC reactor (DCR) is used.

*9 Average braking torque for the motor running alone. It depends on the efficiency of the motor.

Standard-model, Three-phase 400 V (460 V) class series (HD-mode: 55 kW to 250 kW)

Item		Specifications								
Type (VXT-***A-4)		139	168	203	240	290	361	415	520	590
Nominal applied motor (kW) (Output rating) *1		55	75	90	110	132	160	200	220	250
Output ratings	Rated capacity (kVA) *2	85 [89]	114 [120]	134 [140]	160 [167]	193 [202]	232 [242]	287 [300]	316 [331]	364 [380]
	Rated voltage (V) *3	Three-phase 380 to 480 V (with AVR function)								
	Rated current (A) *4	112	150	176	210	253	304	377	415	477
	Overload capability	150%-1 min								
Input power	Voltage, frequency	Three-phase 380 to 480 V, 50/60 Hz			Three-phase 380 to 440 V, 50 Hz Three-phase 380 to 480 V, 60 Hz *5					
	Allowable voltage/frequency	Voltage: +10 to -15% (Interphase voltage unbalance: 2% or less) *6, Frequency: +5 to -5%								
	Rated input current (w/o DCR) (A) *7	140	–	–	–	–	–	–	–	–
	(with DCR) (A)	102	138	164	201	238	286	357	390	443
Required capacity (with DCR) (kVA) *8	71	96	114	140	165	199	248	271	307	
Braking	Torque (%) *9	7% to 12%								
	DC braking	Braking starting frequency: 0.0 to 60.0 Hz, Braking time: 0.0 to 30.0 s, Braking level: 0 to 80%								
	Braking transistor	Separately mounted option								
	Minimum resistance value (Ω)	–								
	Braking resistor	Separately mounted option								
DC reactor (DCR)	Separately mounted option	Must be used. Separately mounted component. *11								
Applicable safety standards	IEC/EN61800-5-1: 2007									
Enclosure (IEC60529)	IP00, UL open type									
Cooling method	Fan cooling									
Weight / Mass (kg)	30	33	40	62	63	95	96	130	140	

*1 4-pole standard motor

*2 Rated capacity is calculated assuming the rated output voltage as 440 V (460 V).

*3 Output voltage cannot exceed the power supply voltage.

*4 Setting the carrier frequency (F26) to the following value or above requires current derating.
HD spec. of all types : 4 kHz

If the ambient temperature is 40°C (104°F) or above, derating of 2%/°C (2%/1.8°F) relative to the rated current given in this manual is required. For details, refer to Figure 10.4-1 in Chapter 10 "10.4.2 Guideline for selecting inverter drive mode and capacity."

*5 Inverters of VXT-203-4 or above (400 V class series) are equipped with a power switching connector. Use the connector depending upon the applied voltage. For details, refer to Chapter 2 "2.2.7 Switching Connector."

*6
$$\text{Voltage unbalance}(\%) = \frac{\text{Max. voltage}(V) - \text{Min. voltage}(V)}{\text{Three-phase average voltage}(V)} \times 67 \quad (\text{IEC 61800-3})$$

If the unbalance ratio is 2% to 3%, use an optional AC reactor (ACR).

*7 This specification is an estimated value to be applied when the power supply capacity is 500 kVA (Inverter capacity × 10 when the capacity exceeds 50 kVA) and the power supply with %X = 5% is connected. When applying with motors of 75 kW or above, a DC reactor (DCR) should be used.

*8 This specification applies when a DC reactor (DCR) is used.

*9 Average braking torque for the motor running alone. It depends on the efficiency of the motor.

*11 Please consult IMO for options.

8.1.3 HND-mode inverters for general load

Standard-model, Three-phase 200 V (230 V) class series (HND-mode: 0.75 kW to 5.5 kW)

Item		Specifications					
Type (VXT-***A-2)		4	6	10	12 *10	20 *10	
Nominal applied motor (kW) (Output rating)	*1	0.75	1.1	2.2	3.0	5.5	
Output ratings	Rated capacity (kVA)	*2	1.3 [1.4]	2.3 [2.4]	3.7 [3.8]	4.6 [4.8]	7.5 [7.8]
	Rated voltage (V)	*3	Three-phase 200 to 240 V (with AVR function)				
	Rated current (A)	*4	3.5	6.0	9.6	12	19.6
	Overload capability		120%-1 min				
Input power	Voltage, frequency		Three-phase 200 to 240 V, 50/60 Hz				
	Allowable voltage/frequency		Voltage: +10 to -15% (Interphase voltage unbalance: 2% or less) *6, Frequency: +5 to -5%				
	Rated input current (w/o DCR) (A)	*7	4.9	6.7	12.8	17.9	31.9
	(with DCR) (A)		3.0	4.3	8.3	11.7	19.9
Required capacity (with DCR) (kVA)	*8	1.1	1.5	2.9	4.1	6.9	
Braking	Torque (%)	*9	53%	68%	48%	29%	27%
	DC braking		Braking starting frequency: 0.0 to 60.0 Hz, Braking time: 0.0 to 30.0 s, Braking level: 0 to 80% (Type VXT12A-2 and VXT20A-2 : 0 to 60%)				
	Braking transistor		Built-in as standard				
	Minimum resistance value (Ω)		100		40		33
	Braking resistor		Separately mounted option				
DC reactor (DCR)		Separately mounted option					
Applicable safety standards		IEC/EN61800-5-1: 2007					
Enclosure (IEC60529)		IP20, UL open type					
Cooling method		Natural cooling		Fan cooling			
Weight / Mass (kg)		0.6	0.8	1.5	1.5	1.8	

*1 4-pole standard motor

*2 Rated capacity is calculated assuming the rated output voltage as 220 V (230 V).

*3 Output voltage cannot exceed the power supply voltage.

*4 Setting the carrier frequency (F26) to the following value or above requires current derating.
HND/ND spec. of types VXT-4A-2 to VXT-20A-2 : 4 kHz,
If reduction is necessary, for details, refer to Chapter 10, Section 10.4.2 "Guideline for selecting inverter
drive mode and capacity."

*6
$$\text{Voltage unbalance}(\%) = \frac{\text{Max. voltage(V)} - \text{Min. voltage(V)}}{\text{Three-phase average voltage(V)}} \times 67 \quad (\text{IEC 61800-3})$$

If the unbalance ratio is 2% to 3%, use an optional AC reactor (ACR).

*7 This specification is an estimated value to be applied when the power supply capacity is 500 kVA (Inverter capacity × 10 when the capacity exceeds 50 kVA) and the power supply with %X = 5% is connected.

*8 This specification applies when a DC reactor (DCR) is used.

*9 Average braking torque for the motor running alone. It depends on the efficiency of the motor.

*10 Types VXT-12A-2 and VXT-20A-2 are ND spec; allowable ambient temperature 40°C (+104°F) or less. The rated output current is decreased 1% for every 1°C (1.8°F) when ambient temperature is +40°C (+104°F) or more.

Standard-model, Three-phase 200 V (230 V) class series (HND-mode: 7.5 kW to 30 kW)

Item		Specifications					
Type (VXT-***A-2)		30	40	56	69	88	115
Nominal applied motor (kW) (Output rating) *1		7.5	11	15	18.5	22	30
Output ratings	Rated capacity (kVA) *2	11 [12]	15 [16]	21 [22]	26 [27]	34 [35]	44 [46]
	Rated voltage (V) *3	Three-phase 200 to 240 V (with AVR function)					
	Rated current (A) *4	30	40	56	69	88	115
	Overload capability	120%-1 min					
Input power	Voltage, frequency	Three-phase 200 to 240 V, 50/60 Hz					
	Allowable voltage/frequency	Voltage: +10 to -15% (Interphase voltage unbalance: 2% or less) *6, Frequency: +5 to -5%					
	Rated input current (w/o DCR) (A) *7	42.7	60.7	80.0	97.0	112	151
	(with DCR) (A)	28.8	42.2	57.6	71.0	84.4	114
Required capacity (with DCR) (kVA) *8	10	15	20	25	30	40	
Braking	Torque (%) *9	15%					
	DC braking	Braking starting frequency: 0.0 to 60.0 Hz, Braking time: 0.0 to 30.0 s, Braking level: 0 to 80%					
	Braking transistor	Built-in as standard					
	Minimum resistance value (Ω)	20	15	10	8.6	4	
	Braking resistor	Separately mounted option					
DC reactor (DCR)	Separately mounted option						
Applicable safety standards	IEC/EN61800-5-1: 2007						
Enclosure (IEC60529)	IP20, UL open type						
Cooling method	Fan cooling						
Weight / Mass (kg)	5.0	5.0	8.0	9.0	9.5	10	

*1 4-pole standard motor

*2 Rated capacity is calculated assuming the rated output voltage as 220 V (230 V).

*3 Output voltage cannot exceed the power supply voltage.

*4 Setting the carrier frequency (F26) to the following value or above requires current derating.
HND spec of type VXT-30A-2 to VXT-115A-2: 10 kHz
HND spec of type VXT-88A-2, VXT-115A-2: 4 kHz
If reduction is necessary, for details, refer to Chapter 10 "10.4.2 Guideline for selecting inverter drive mode and capacity."

*6
$$\text{Voltage unbalance(\%)} = \frac{\text{Max. v oltage(V)} - \text{Min. v oltage(V)}}{\text{Three - phase av erage v oltage(V)}} \times 67 \quad (\text{IEC 61800-3})$$

If the unbalance ratio is 2% to 3%, use an optional AC reactor (ACR).

*7 This specification is an estimated value to be applied when the power supply capacity is 500 kVA (Inverter capacity × 10 when the capacity exceeds 50 kVA) and the power supply with %X = 5% is connected.

*8 This specification applies when a DC reactor (DCR) is used.

*9 Average braking torque for the motor running alone. It depends on the efficiency of the motor.

Standard-model, Three-phase 400 V (460 V) class series (HND-mode: 0.75 kW to 5.5 kW)

Item		Specifications				
Type (VXT-***A-4)		2	4	6	7 *10	12 *10
Nominal applied motor (kW) (Output rating) *1		0.75	1.1	2.2	3.0	5.5
Output ratings	Rated capacity (kVA) *2	1.4 [1.4]	2.6 [2.7]	3.8 [4.0]	4.8 [5.0]	8.5 [8.8]
	Rated voltage (V) *3	Three-phase 380 to 480 V (with AVR function)				
	Rated current (A) *4	1.8	3.4	5.0	6.3	11.1
	Overload capability	120%-1 min				
Input power	Voltage, frequency	Three-phase 380 to 480 V, 50/60 Hz				
	Allowable voltage/frequency	Voltage: +10 to -15% (Interphase voltage unbalance: 2% or less) *6, Frequency: +5 to -5%				
	Rated input current (w/o DCR) (A) *7	2.7	3.9	7.3	11.3	16.8
	(with DCR) (A)	1.5	2.1	4.2	5.8	10.1
Required capacity (with DCR) (kVA) *8	1.1	1.5	3.0	4.1	7.0	
Braking	Torque (%) *9	53%	68%	48%	29%	27%
	DC braking	Braking starting frequency: 0.0 to 60.0 Hz, Braking time: 0.0 to 30.0 s, Braking level: 0 to 80% (Type VXT-7A-2 and VXT-12A-2 : 0 to 60%)				
	Braking transistor	Built-in as standard				
	Minimum resistance value (Ω)	200		160		130
	Braking resistor	Separately mounted option				
DC reactor (DCR)		Separately mounted option				
Applicable safety standards		IEC/EN61800-5-1: 2007				
Enclosure (IEC60529)		IP20, UL open type				
Cooling method		Natural cooling			Fan cooling	
Weight / Mass (kg)		1.2	1.5	1.5	1.6	1.9

*1 4-pole standard motor

*2 Rated capacity is calculated assuming the rated output voltage as 440 V (460 V).

*3 Output voltage cannot exceed the power supply voltage.

*4 Setting the carrier frequency (F26) to the following value or above requires current derating.
HND spec of type VXT-2A-4 to VXT-6A-4: 8 kHz,
ND spec of type VXT-7A-4 to VXT-12A-4: 4 kHz,
HND spec of type VXT-22A-4 to VXT-59A-4: 10 kHz,
HND spec of type VXT-72A-4 to VXT-168A-4: 6 kHz,
HND spec of type VXT-203A-4 to VXT-590A-4: 4 kHz
If reduction is necessary, for details, refer to Figure 10.4-1 in Chapter 10 "10.4.2 Guideline for selecting inverter drive mode and capacity."

*6
$$\text{Voltage unbalance}(\%) = \frac{\text{Max. voltage}(\text{V}) - \text{Min. voltage}(\text{V})}{\text{Three-phase average voltage}(\text{V})} \times 67 \quad (\text{IEC 61800-3})$$

If the unbalance ratio is 2% to 3%, use an optional AC reactor (ACR).

*7 This specification is an estimated value to be applied when the power supply capacity is 500 kVA (Inverter capacity × 10 when the capacity exceeds 50 kVA) and the power supply with %X = 5% is connected. When applying with motors of 75 kW or above, a DC reactor (DCR) should be used.

*8 This specification applies when a DC reactor (DCR) is used.

*9 Average braking torque for the motor running alone. It depends on the efficiency of the motor.)

*10 Types VXT-7A-4 and VXT-12A-4 are ND spec; allowable ambient temperature 40°C (+104°F) or less. The rated output current is decreased 1% for every 1°C (1.8°F) when ambient temperature is +40°C (+104°F) or more.

Standard-model, Three-phase 400 V (460 V) class series (HND-mode: 7.5 kW to 45 kW)

Item		Specifications							
Type (VXT-***A-4)		22	29	37	44	59	72	85	105
Nominal applied motor (kW) (Output rating) *1		7.5	11	15	18.5	22	30	37	45
Output ratings	Rated capacity (kVA) *2	13 [14]	18 [18]	24 [25]	29 [30]	34 [36]	46 [48]	57 [60]	69 [73]
	Rated voltage (V) *3	Three-phase 380 to 480 V (with AVR function)							
	Rated current (A) *4	17.5	23	31	38	45	60	75	91
	Overload capability	120%-1 min							
Input power	Voltage, frequency	Three-phase 380 to 480 V, 50/60 Hz							
	Allowable voltage/frequency	Voltage: +10 to -15% (Interphase voltage unbalance: 2% or less) *6, Frequency: +5 to -5%							
	Rated input current (w/o DCR) (A) *7	23.2	33	43.8	52.3	60.6	77.9	94.3	114
	(with DCR) (A)	14.4	21.1	28.8	35.5	42.2	57.0	68.5	83.2
Required capacity (with DCR) (kVA) *8	10	15	20	25	29	39	47	58	
Braking	Torque (%) *9	15%					7% to 12%		
	DC braking	Braking starting frequency: 0.0 to 60.0 Hz, Braking time: 0.0 to 30.0 s, Braking level: 0 to 80%							
	Braking transistor	Built-in as standard						Separately mounted option	
	Minimum resistance value (Ω)	80	60	40	34.4	16		-	-
	Braking resistor	Separately mounted option							
DC reactor (DCR)	Separately mounted option								
Applicable safety standards	IEC/EN61800-5-1: 2007								
Enclosure (IEC60529)	IP20, UL open type						IP00, UL open type		
Cooling method	Fan cooling								
Weight / Mass (kg)	5.0	5.0	8.0	9.0	9.5	10	25	26	

*1 4-pole standard motor

*2 Rated capacity is calculated assuming the rated output voltage as 440 V (460 V).

*3 Output voltage cannot exceed the power supply voltage.

*4 Setting the carrier frequency (F26) to the following value or above requires current derating.
HND spec of type VXT-22A-4 to VXT-59A-4: 10 kHz,
HND spec of type VXT-72A-4 to VXT-168A-4: 6 kHz,
HND spec of type VXT-203A-4 to VXT-590A-4: 4 kHz
If reduction is necessary, for details, refer to Figure 10.4-1 in Chapter 10 "10.4.2 Guideline for selecting inverter drive mode and capacity."

*6
$$\text{Voltage unbalance}(\%) = \frac{\text{Max. voltage(V)} - \text{Min. voltage(V)}}{\text{Three-phase average voltage(V)}} \times 67 \quad (\text{IEC 61800-3})$$

If the unbalance ratio is 2% to 3%, use an optional AC reactor (ACR).

*7 This specification is an estimated value to be applied when the power supply capacity is 500 kVA (Inverter capacity × 10 when the capacity exceeds 50 kVA) and the power supply with %X = 5% is connected. When applying with motors of 75 kW or above, a DC reactor (DCR) should be used.

*8 This specification applies when a DC reactor (DCR) is used.

*9 Average braking torque for the motor running alone. It depends on the efficiency of the motor.

Standard-model, Three-phase 400 V (460 V) class series (HND-mode: 55 kW to 280 kW)

Item		Specifications								
Type (VXT-***A-4)		139	168	203	240	290	361	415	520	590
Nominal applied motor (kW) (Output rating) *1		55	75	90	110	132	160	200	220	280
Output ratings	Rated capacity (kVA) *2	85 [89]	114 [120]	134 [140]	160 [167]	193 [202]	232 [242]	287 [300]	316 [331]	396 [380]
	Rated voltage (V) *3	Three-phase 380 to 480 V (with AVR function)								
	Rated current (A) *4	112	150	176	210	253	304	377	415	520
	Overload capability	120%-1 min								
Input power	Voltage, frequency	Three-phase 380 to 480 V, 50/60 Hz			Three-phase 380 to 440 V, 50 Hz Three-phase 380 to 480 V, 60 Hz *5					
	Allowable voltage/frequency	Voltage: +10 to -15% (Interphase voltage unbalance: 2% or less) *6, Frequency: +5 to -5%								
	Rated input current (w/o DCR) (A) *7	140	–	–	–	–	–	–	–	–
	(with DCR) (A)	102	138	164	201	238	286	357	390	500
Required capacity (with DCR) (kVA) *8	71	96	114	140	165	199	248	271	347	
Braking	Torque (%) *9	7% to 12%								
	DC braking	Braking starting frequency: 0.0 to 60.0 Hz, Braking time: 0.0 to 30.0 s, Braking level: 0 to 80%								
	Braking transistor	Separately mounted option								
	Minimum resistance value (Ω)									
	Braking resistor	Separately mounted option								
DC reactor (DCR)	Separately mounted option	Must be used. Separately mounted component. *11								
Applicable safety standards	IEC/EN61800-5-1: 2007									
Enclosure (IEC60529)	IP00, UL open type									
Cooling method	Fan cooling									
Weight / Mass (kg)	30	33	40	62	63	95	96	130	140	

*1 4-pole standard motor

*2 Rated capacity is calculated assuming the rated output voltage as 440 V (460 V).

*3 Output voltage cannot exceed the power supply voltage.

*4 Setting the carrier frequency (F26) to the following value or above requires current derating.
HND spec of type VXT-22A-4 to VXT-59A-4: 10 kHz,
HND spec of type VXT-72A-4 to VXT-168A-4: 6 kHz,
HND spec of type VXT-203A-4 to VXT-590A-4: 4 kHz
If reduction is necessary, for details, refer to Figure 10.4-1 in Chapter 10 "10.4.2 Guideline for selecting inverter drive mode and capacity."

*5 Inverters of VXT-203A-4 or above (400 V class series) are equipped with a power switching connector. Use the connector depending upon the applied voltage. For details, refer to Chapter 2 "2.2.7 Switching Connector."

$$*6 \text{ Voltage unbalance}(\%) = \frac{\text{Max. voltage}(\text{V}) - \text{Min. voltage}(\text{V})}{\text{Three-phase average voltage}(\text{V})} \times 67 \text{ (IEC 61800-3)}$$

If the unbalance ratio is 2% to 3%, use an optional AC reactor (ACR).

*7 This specification is an estimated value to be applied when the power supply capacity is 500 kVA (Inverter capacity × 10 when the capacity exceeds 50 kVA) and the power supply with %X = 5% is connected. When applying with motors of 75 kW or above, a DC reactor (DCR) should be used.

*8 This specification applies when a DC reactor (DCR) is used.

*9 Average braking torque for the motor running alone. It depends on the efficiency of the motor.

*11 Please consult IMO for options.

8.1.4 HHD-mode inverters for heavy duty load

Standard-model, Three-phase 200 V (230 V) class series (HHD-mode: 0.4 kW to 4.0 kW)

Item		Specifications					
Type (VXT-***A-2)		4	6	10	12	20	
Nominal applied motor (kW) (Output rating)	*1	0.4	0.75	1.5	2.2	4.0	
Output ratings	Rated capacity (kVA)	*2	1.1 [1.2]	1.9 [2.0]	3.0 [3.2]	4.2 [4.4]	6.7 [7.0]
	Rated voltage (V)	*3	Three-phase 200 to 240 V (with AVR function)				
	Rated current (A)	*4	3.0	5.0	8.0	11	17.5
	Overload capability		150%-1 min, 200%-0.5 s				
Input power	Voltage, frequency		Three-phase 200 to 240 V, 50/60 Hz				
	Allowable voltage/frequency		Voltage: +10 to -15% (Interphase voltage unbalance: 2% or less) *6, Frequency: +5 to -5%				
	Rated input current (w/o DCR) (A)	*7	3.1	5.3	9.5	13.2	22.2
	(with DCR) (A)		1.6	3.0	5.7	8.3	14.0
Required capacity (with DCR) (kVA)	*8	0.6	1.1	2.0	2.9	4.9	
Braking	Torque (%)	*9	100%		70%	40%	
	DC braking		Braking starting frequency: 0.0 to 60.0 Hz, Braking time: 0.0 to 30.0 s, Braking level: 0 to 100%				
	Braking transistor		Built-in as standard				
	Minimum resistance value(Ω)		100		40	33	
	Braking resistor		Separately mounted option				
DC reactor (DCR)		Separately mounted option					
Applicable safety standards		IEC/EN61800-5-1: 2007					
Enclosure (IEC60529)		IP20, UL open type					
Cooling method		Natural cooling		Fan cooling			
Weight / Mass (kg)		0.6	0.8	1.5	1.5	1.8	

*1 4-pole standard motor

*2 Rated capacity is calculated assuming the rated output voltage as 220 V (230 V).

*3 Output voltage cannot exceed the power supply voltage.

*4 Setting the carrier frequency (F26) to the following value or above requires current derating.
HHD spec. of types VXT-4A-2 to VXT-20A-2 : 8 kHz,
HHD spec. of types VXT-30A-2 to VXT-115A-2 : 10 kHz,
If reduction is necessary, for details, refer to Chapter 10, Section 10.4.2 "Guideline for selecting inverter drive mode and capacity."

*6
$$\text{Voltage unbalance}(\%) = \frac{\text{Max. voltage(V)} - \text{Min. voltage(V)}}{\text{Three-phase average voltage(V)}} \times 67 \quad (\text{IEC 61800-3})$$

If the unbalance ratio is 2% to 3%, use an optional AC reactor (ACR).

*7 This specification is an estimated value to be applied when the power supply capacity is 500 kVA (Inverter capacity × 10 when the capacity exceeds 50 kVA) and the power supply with %X = 5% is connected.

*8 This specification applies when a DC reactor (DCR) is used.

*9 Average braking torque for the motor running alone. It depends on the efficiency of the motor.

Standard-model, Three-phase 200 V (230 V) class series (HHD-mode: 5.5 kW to 22 kW)

Item		Specifications					
Type (VXT-***A-2)		30	40	56	69	88	115
Nominal applied motor (kW) (Output rating) *1		5.5	7.5	11	15	18.5	22
Output ratings	Rated capacity (kVA) *2	9.5 [10]	13 [13]	18 [19]	23 [24]	29 [30]	34 [36]
	Rated voltage (V) *3	Three-phase 200 to 240 V (with AVR function)					
	Rated current (A) *4	25	33	47	60	76	90
	Overload capability	150%-1 min, 200%-0.5 s					
Input power	Voltage, frequency	Three-phase 200 to 240 V, 50/60 Hz					
	Allowable voltage/frequency	Voltage: +10 to -15% (Interphase voltage unbalance: 2% or less) *6, Frequency: +5 to -5%					
	Rated input current (w/o DCR) (A) *7	31.5	42.7	60.7	80.0	97.0	112
	(with DCR) (A)	21.1	28.8	42.2	57.6	71.0	84.4
Required capacity (with DCR) (kVA) *8	7.3	10	15	20	25	30	
Braking	Torque (%) *9	20%					
	DC braking	Braking starting frequency: 0.0 to 60.0 Hz, Braking time: 0.0 to 30.0 s, Braking level: 0 to 100%					
	Braking transistor	Built-in as standard					
	Minimum resistance value (Ω)	20	15	10	8.6	4	
	Braking resistor	Separately mounted option					
DC reactor (DCR)	Separately mounted option						
Applicable safety standards	IEC/EN61800-5-1: 2007						
Enclosure (IEC60529)	IP20, UL open type						
Cooling method	Fan cooling						
Weight / Mass (kg)	5.0	5.0	8.0	9.0	9.5	10	

*1 4-pole standard motor

*2 Rated capacity is calculated assuming the rated output voltage as 220 V (230 V).

*3 Output voltage cannot exceed the power supply voltage.

*4 Setting the carrier frequency (F26) to the following value or above requires current derating.
HHD spec. of types VXT-30A-2 to VXT-115A-2: 10 kHz
If reduction is necessary, for details, refer to Figure 10.4-1 in Chapter 10 "10.4.2 Guideline for selecting inverter drive mode and capacity."

*6
$$\text{Voltage unbalance}(\%) = \frac{\text{Max. voltage(V)} - \text{Min. voltage(V)}}{\text{Three-phase average voltage(V)}} \times 67 \quad (\text{IEC 61800-3})$$

If the unbalance ratio is 2% to 3%, use an optional AC reactor (ACR).

*7 This specification is an estimated value to be applied when the power supply capacity is 500 kVA (Inverter capacity × 10 when the capacity exceeds 50 kVA) and the power supply with %X = 5% is connected.

*8 This specification applies when a DC reactor (DCR) is used.

*9 Average braking torque for the motor running alone. It depends on the efficiency of the motor.

Standard-model, Three-phase 400 V (460 V) class series (HHD-mode: 0.4 kW to 4.0 kW)

Item		Specifications				
Type (VXT-***A-4)		2	4	6	7	12
Nominal applied motor (kW) (Output rating) *1		0.4	0.75	1.5	2.2	4.0
Output ratings	Rated capacity (kVA) *2	1.1 [1.2]	1.9 [2.0]	3.2 [3.3]	4.2 [4.4]	6.9 [7.2]
	Rated voltage (V) *3	Three-phase 380 to 480 V (with AVR function)				
	Rated current (A) *4	1.5	2.5	4.2	5.5	9.0
	Overload capability	150%-1 min, 200%-0.5 s				
Input power	Voltage, frequency	Three-phase 380 to 480 V, 50/60 Hz				
	Allowable voltage/frequency	Voltage: +10 to -15% (Interphase voltage unbalance: 2% or less) *6, Frequency: +5 to -5%				
	Rated input current (w/o DCR) (A) *7	1.7	3.1	5.9	8.2	13.0
	(with DCR) (A)	0.85	1.6	3.0	4.4	7.3
Required capacity (with DCR) (kVA) *8	0.6	1.2	2.1	3.1	5.1	
Braking	Torque (%) *9	100%		70%	40%	
	DC braking	Braking starting frequency: 0.0 to 60.0 Hz, Braking time: 0.0 to 30.0 s, Braking level: 0 to 100%				
	Braking transistor	Built-in as standard				
	Minimum resistance value (Ω)	200		160	130	
	Braking resistor	Separately mounted option				
DC reactor (DCR)	Separately mounted option					
Applicable safety standards	IEC/EN61800-5-1: 2007					
Enclosure (IEC60529)	IP20, UL open type					
Cooling method	Fan cooling					
Weight / Mass (kg)	1.2	1.5	1.5	1.6	1.9	

*1 4-pole standard motor

*2 Rated capacity is calculated assuming the rated output voltage as 440 V (460 V).

*3 Output voltage cannot exceed the power supply voltage.

*4 Setting the carrier frequency (F26) to the following value or above requires current derating.
HHD spec of type VXT-2A-4 to VXT-12A-4: 8 kHz,
HHD spec of type VXT-22A-4 to VXT-168A-4: 10 kHz,
HHD spec of type VXT-203A-4 to VXT-590A-4: 6 kHz,
If reduction is necessary, for details, refer to Figure 10.4-1 in Chapter 10 "10.4.2 Guideline for selecting inverter drive mode and capacity."

*6
$$\text{Voltage unbalance}(\%) = \frac{\text{Max. voltage(V)} - \text{Min. voltage(V)}}{\text{Three-phase average voltage(V)}} \times 67 \quad (\text{IEC 61800-3})$$

If the unbalance ratio is 2% to 3%, use an optional AC reactor (ACR).

*7 This specification is an estimated value to be applied when the power supply capacity is 500 kVA (Inverter capacity × 10 when the capacity exceeds 50 kVA) and the power supply with %X = 5% is connected. When applying with motors of 75 kW or above, a DC reactor (DCR) should be used.

*8 This specification applies when a DC reactor (DCR) is used.

*9 Average braking torque for the motor running alone. It depends on the efficiency of the motor.

Standard-model, Three-phase 400 V (460 V) class series (HHD-mode: 5.5 kW to 37 kW)

Item		Specifications							
Type (VXT-***A-4)		22	29	37	44	59	72	85	105
Nominal applied motor (kW) (Output rating) *1		5.5	7.5	11	15	18.5	22	30	37
Output ratings	Rated capacity (kVA) *2	9.9 [10]	14 [14]	18 [19]	23 [24]	30 [31]	34 [36]	46 [48]	57 [60]
	Rated voltage (V) *3	Three-phase 380 to 480 V (with AVR function)							
	Rated current (A) *4	13	18	24	30	39	45	60	75
	Overload capability	150%-1 min, 200%-0.5 s							
Input power	Voltage, frequency	Three-phase 380 to 480 V, 50/60 Hz							
	Allowable voltage/frequency	Voltage: +10 to -15% (Interphase voltage unbalance: 2% or less) *6, Frequency: +5 to -5%							
	Rated input current (w/o DCR) (A) *7	17.3	23.2	33	43.8	52.3	60.6	77.9	94.3
	(with DCR) (A)	10.6	14.4	21.1	28.8	35.5	42.2	57.0	68.5
Required capacity (with DCR) (kVA) *8	7.3	10	15	20	25	29	39	47	
Braking	Torque (%) *9	20%					10% to 15%		
	DC braking	Braking starting frequency: 0.0 to 60.0 Hz, Braking time: 0.0 to 30.0 s, Braking level: 0 to 100%							
	Braking transistor	Built-in as standard							
	Minimum resistance value (Ω)	80	60	40	34.4	16	—		
	Braking resistor	Separately mounted option							
DC reactor (DCR)		Separately mounted option							
Applicable safety standards		IEC/EN61800-5-1: 2007							
Enclosure (IEC60529)		IP20, UL open type							
Cooling method		Fan cooling							
Weight / Mass (kg)		5.0	5.0	8.0	9.0	9.5	10	25	26

*1 4-pole standard motor

*2 Rated capacity is calculated assuming the rated output voltage as 440 V (460 V).

*3 Output voltage cannot exceed the power supply voltage.

*4 Setting the carrier frequency (F26) to the following value or above requires current derating.
HHD spec of type VXT-2A-4 to VXT-12A-4: 8 kHz,
HHD spec of type VXT-22A-4 to VXT-168A-4: 10 kHz,
HHD spec of type VXT-203A-4 to VXT-590A-4: 6 kHz,
If reduction is necessary, for details, refer to Figure 10.4-1 in Chapter 10 "10.4.2 Guideline for selecting inverter drive mode and capacity."

*6
$$\text{Voltage unbalance}(\%) = \frac{\text{Max. voltage(V)} - \text{Min. voltage(V)}}{\text{Three-phase average voltage(V)}} \times 67 \quad (\text{IEC 61800-3})$$

If the unbalance ratio is 2% to 3%, use an optional AC reactor (ACR).

*7 This specification is an estimated value to be applied when the power supply capacity is 500 kVA (Inverter capacity × 10 when the capacity exceeds 50 kVA) and the power supply with %X = 5% is connected. When applying with motors of 75 kW or above, a DC reactor (DCR) should be used.

*8 This specification applies when a DC reactor (DCR) is used.

*9 Average braking torque for the motor running alone. It depends on the efficiency of the motor.

Standard-model, Three-phase 400 V (460 V) class series (HHD-mode: 45 kW to 220 kW)

Item		Specifications								
Type (VXT-***A-4)		139	168	203	240	290	361	415	520	590
Nominal applied motor (kW) (Output rating) *1		45	55	75	90	110]	132	160	200	220
Output ratings	Rated capacity (kVA) *2	69 [73]	85 [89]	114 [120]	134 [140]	160 [167]	193 [202]	232 [242]	287 [300]	316 [331]
	Rated voltage (V) *3	Three-phase 380 to 480 V (with AVR function)								
	Rated current (A) *4	91	112	150	176	210	253	304	377	415
	Overload capability	150%-1 min, 200%-0.5 s								
Input power	Voltage, frequency	Three-phase 380 to 480 V, 50/60 Hz		Three-phase 380 to 440 V, 50 Hz Three-phase 380 to 480 V, 60 Hz *5						
	Allowable voltage/frequency	Voltage: +10 to -15% (Interphase voltage unbalance: 2% or less) *6, Frequency: +5 to -5%								
	Rated input current (w/o DCR) (A) *7	114	140	–	–	–	–	–	–	–
	(with DCR) (A)	83.2	102	138	164	201	238	286	357	390
Required capacity (with DCR) (kVA) *8	58	71	96	114	140	165	199	248	271	
Braking	Torque (%) *9	10% to 15%								
	DC braking	Braking starting frequency: 0.0 to 60.0 Hz, Braking time: 0.0 to 30.0 s, Braking level: 0 to 100%								
	Braking transistor	Separately mounted option								
	Minimum resistance value (Ω)									
	Braking resistor	Separately mounted option								
DC reactor (DCR)	Separately mounted option		Must be used. Separately mounted component. *11							
Applicable safety standards	IEC/EN61800-5-1: 2007									
Enclosure (IEC60529)	IP00, UL open type									
Cooling method	Fan cooling									
Weight / Mass (kg)	30	33	40	62	63	95	96	130	140	

*1 4-pole standard motor

*2 Rated capacity is calculated assuming the rated output voltage as 440 V (460 V).

*3 Output voltage cannot exceed the power supply voltage.

*4 Setting the carrier frequency (F26) to the following value or above requires current derating.
HHD spec of type VXT-22A-4 to VXT-168A-4: 10 kHz,
HHD spec of type VXT203A-4 to VXT590A-4: 6 kHz,
If reduction is necessary, for details, refer to Figure 10.4-1 in Chapter 10 "10.4.2 Guideline for selecting inverter drive mode and capacity."

*5 Inverters of VXT-203A-4 or above (400 V class series) are equipped with a power switching connector. Use the connector depending upon the applied voltage. For details, refer to Chapter 2 "2.2.7 Switching Connector."

*6
$$\text{Voltage unbalance}(\%) = \frac{\text{Max. voltage}(\text{V}) - \text{Min. voltage}(\text{V})}{\text{Three-phase average voltage}(\text{V})} \times 67 \quad (\text{IEC 61800-3})$$

If the unbalance ratio is 2% to 3%, use an optional AC reactor (ACR).

*7 This specification is an estimated value to be applied when the power supply capacity is 500 kVA (Inverter capacity × 10 when the capacity exceeds 50 kVA) and the power supply with %X = 5% is connected. When applying with motors of 75 kW or above, a DC reactor (DCR) should be used.

*8 This specification applies when a DC reactor (DCR) is used.

*9 Average braking torque for the motor running alone. It depends on the efficiency of the motor.

*11 Please consult IMO for options.

Standard-model, Single-phase 200 V (230 V) class series (HHD-mode: 0.4 kW to 2.2 kW)

Item		Specifications			
Type (VXT-***A-1)		3	5	8	11
Nominal applied motor (kW) (Output rating) *1		0.4	0.75	1.5	2.2
Output ratings	Rated capacity (kVA) *2	1.1 [1.2]	1.9 [2.0]	3.0 [3.2]	4.2 [4.4]
	Rated voltage (V) *3	Three-phase 200 to 240 V (with AVR function)			
	Rated current (A) *4	3.0	5.0	8.0	11
	Overload capability	150%-1 min, 200%-0.5 s			
Input power	Voltage, frequency	Single-phase 200 to 240 V, 50/ 60 Hz			
	Allowable voltage/frequency	Voltage: +10 to -10%, Frequency: +5 to -5%			
	Rated input current (w/o DCR) (A) *7	5.4	9.7	16.4	24.8
	(with DCR) (A)	3.5	6.4	11.6	17.5
Required capacity (with DCR) (kVA) *8	0.7	1.3	2.4	3.5	
Braking	Torque (%) *9	100%		70%	40%
	DC braking	Braking starting frequency: 0.0 to 60.0 Hz, Braking time: 0.0 to 30.0 s, Braking level: 0 to 100%			
	Braking transistor	Built-in as standard			
	Minimum resistance value (Ω)	100		40	
	Braking resistor	Separately mounted option			
DC reactor (DCR)	Separately mounted option				
Applicable safety standards	IEC/EN61800-5-1: 2007				
Enclosure (IEC60529)	IP00, UL open type				
Cooling method	Natural cooling		Fan cooling		
Weight / Mass (kg)	0.6	0.9	1.6	1.8	

*1 4-pole standard motor

*2 Rated capacity is calculated assuming the rated output voltage as 220 V (230 V).

*3 Output voltage cannot exceed the power supply voltage.

*4 Setting the carrier frequency (F26) to the following value or above requires current derating.
HHD spec of type VXT-3A-1 to VXT-11A-1: 8 kHz,
If reduction is necessary, for details, refer to Figure 10.4-1 in Chapter 10 "10.4.2 "Guideline for selecting inverter drive mode and capacity."

*7 This specification is an estimated value to be applied when the power supply capacity is 500 kVA (Inverter capacity \times 10 when the capacity exceeds 50 kVA) and the power supply with %X = 5% is connected.

*8 This specification applies when a DC reactor (DCR) is used.

*9 Average braking torque for the motor running alone. It depends on the efficiency of the motor.

8.2 EMC Filter Built-in Type

8.2.1 ND-mode inverters for general load

Three-phase 400 V (460 V) class series

Item	Specifications				
Type (VXT-***A-4E)	2	4	6	7	12
Nominal applied motor (kW) (Output rating) *1	0.75	1.5	2.2	3.0	5.5
EMC filter	Compliant with EMC Directives. Emission: Category C2. Immunity: 2nd Env. (EN61800-3:2004)				
Weight / Mass (kg)	1.5	1.8	2.3	2.3	2.4

Item	Specifications							
Type (VXT-***A-4E)	22	29	37	44	59	72	85	105
Nominal applied motor (kW) (Output rating) *1	11	15	18.5	22	30	37	45	55
EMC filter	Compliant with EMC Directives. Emission: Category C3. Immunity: 2nd Env. (EN61800-3:2004)							
Weight / Mass (kg)	6.5	6.5	11.2	11.2	10.5	11.2	26	27

Item	Specifications									
Type (VXT-***A-4E)	139	168	203	240	290	361	415	520	590	
Nominal applied motor (kW) (Output rating) *1	75	90	110	132	160	200	220	280	315	
EMC filter	Compliant with EMC Directives. Emission: Category C3. Immunity: 2nd Env. (EN61800-3:2004)									
Weight / Mass (kg)	31	33	40	62	63	95	96	130	140	

*1 4-pole standard motor

The specification other than the above items is the same as "8.1.1 ND-mode inverters for general load".

8.2.2 HD-mode inverters for heavy duty load

Three-phase 400 V (460 V) class series

Item	Specifications				
Type (VXT-***A-4E)	2	4	6	7	12
Nominal applied motor (kW) (Output rating) *1	0.75	1.1	2.2	3.0	5.5
EMC filter	Compliant with EMC Directives. Emission: Category C2. Immunity: 2nd Env. (EN61800-3:2004)				
Weight / Mass (kg)	1.5	1.8	2.3	2.3	2.4

Item	Specifications							
Type (VXT-***A-4E)	22	29	37	44	59	72	85	105
Nominal applied motor (kW) (Output rating) *1	7.5	11	15	18.5	22	30	37	45
EMC filter	Compliant with EMC Directives. Emission: Category C3. Immunity: 2nd Env. (EN61800-3:2004)							
Weight / Mass (kg)	6.5	6.5	11.2	11.2	10.5	11.2	26	27

Item	Specifications									
Type (VXT-***A-4E)	139	168	203	240	290	361	415	520	590	
Nominal applied motor (kW) (Output rating) *1	55	75	90	110	132	160	200	220	250	
EMC filter	Compliant with EMC Directives. Emission: Category C3. Immunity: 2nd Env. (EN61800-3:2004)									
Weight / Mass (kg)	31	33	40	62	63	95	96	130	140	

*1 4-pole standard motor

The specification other than the above items is the same as "8.1.2 HD-mode inverters for heavy duty load".

8.2.3 HND-mode inverters for general load

Three-phase 400 V (460 V) class series

Item	Specifications				
Type (VXT-***A-4E)	2	4	6	7 *10	12 *10
Nominal applied motor (kW) (Output rating) *1	0.75	1.1	2.2	3.0	5.5
EMC filter	Compliant with EMC Directives. Emission: Category C2. Immunity: 2nd Env. (EN61800-3:2004)				
Weight / Mass (kg)	1.5	1.8	2.3	2.3	2.4

Item	Specifications							
Type (VXT-***A-4E)	22	29	37	44	59	72	85	105
Nominal applied motor (kW) (Output rating) *1	7.5	11	15	18.5	22	30	37	45
EMC filter	Compliant with EMC Directives. Emission: Category C3. Immunity: 2nd Env. (EN61800-3:2004)							
Weight / Mass (kg)	6.5	6.5	11.2	11.2	10.5	11.2	26	27

Item	Specifications									
Type (VXT-***A-4E)	139	168	203	240	290	361	415	520	590	
Nominal applied motor (kW) (Output rating) *1	55	75	90	110	132	160	200	220	280	
EMC filter	Compliant with EMC Directives. Emission: Category C3. Immunity: 2nd Env. (EN61800-3:2004)									
Weight / Mass (kg)	31	33	40	62	63	95	96	130	140	

*1 4-pole standard motor

*10 Types VXT7A-4E and VXT-12A-4E are ND spec; allowable ambient temperature 40°C (+104°F) or less. The rated output current is decreased 1% for every 1°C (1.8°F) when ambient temperature is +40°C (+104°F) or more.

The specification other than the above items is the same as "8.1.3 HND-mode inverters for general load".

8.2.4 HHD-mode inverters for heavy duty load

Three-phase 400 V (460 V) class series

Item	Specifications				
Type (VXT-***A-4E)	2	4	6	7	12
Nominal applied motor (kW) (Output rating) *1	0.4	0.75	1.5	2.2	4.0
EMC filter	Compliant with EMC Directives. Emission: Category C2. Immunity: 2nd Env. (EN61800-3:2004)				
Weight / Mass (kg)	1.5	1.8	2.3	2.3	2.4

Item	Specifications							
Type (VXT-***A-4E)	22	29	37	44	59	72	85	105
Nominal applied motor (kW) (Output rating) *1	5.5	7.5	11	15	18.5	22	30	37
EMC filter	Compliant with EMC Directives. Emission: Category C3. Immunity: 2nd Env. (EN61800-3:2004)							
Weight / Mass (kg)	6.5	6.5	11.2	11.2	10.5	11.2	26	27

Item	Specifications									
Type (VXT-***A-4E)	0139	0168	0203	0240	0290	0361	0415	0520	0590	
Nominal applied motor (kW) (Output rating) *1	45	55	75	90	110	132	160	200	220	
EMC filter	Compliant with EMC Directives. Emission: Category C3. Immunity: 2nd Env. (EN61800-3:2004)									
Weight / Mass (kg)	31	33	40	62	63	95	96	130	140	

Single-phase 200 V (230 V) class series







Item	Specifications			
Type (VXT-***A-1E)	3	5	8	11
Nominal applied motor (kW) (Output rating) *1	0.4	0.75	1.5	2.2
EMC filter	Compliant with EMC Directives. Emission: Category C2. Immunity: 2nd Env. (EN61800-3:2004)			
Weight / Mass (kg)	0.7	1.1	2.3	2.3



*1 4-pole standard motor

The specification other than the above items is the same as "8.1.4 HHD-mode inverters for heavy duty load".

8.3 Common Specifications

Item		Explanation	Remarks	
Output	Setting range	Maximum frequency	HHD/HND/HD mode: 25 to 500 Hz variable (under V/f control, Magnetic pole position sensorless vector control) (Up to 200 Hz in case of under vector control with speed sensor) ND mode: 25 to 120 Hz (under any drive control)	IMPG-VC
		Base frequency	25 to 500 Hz variable (in conjunction with the maximum frequency)	
		Starting frequency	0.1 to 60.0 Hz variable (0.0 Hz under vector control with speed sensor)	IMPG-VC
		Carrier frequency	<p>Three phase 200 V class series</p> <p>VXT-4A-2 to VXT-10A-2, VXT-30A-2 to VXT-88A-2:</p> <ul style="list-style-type: none"> 0.75 to 16 kHz variable (HHD/HND spec.) <p>VXT-12A-2 to VXT-20A-2:</p> <ul style="list-style-type: none"> 0.75 to 16 kHz variable (HHD spec.) 0.75 to 10 kHz variable (ND spec.) <p>VXT-115A-2:</p> <ul style="list-style-type: none"> 0.75 to 16 kHz variable (HHD spec.) 0.75 to 10 kHz variable (HND spec.) <p>Three phase 400 V class series</p> <p>VXT-2A-4 to VXT-59A-4:</p> <ul style="list-style-type: none"> 0.75 to 16 kHz variable (HHD/HND/HD spec.) 0.75 to 10 kHz variable (ND spec.) <p>VXT-72A-4 to VXT-168A-4:</p> <ul style="list-style-type: none"> 0.75 to 16 kHz variable (HHD spec.) 0.75 to 10 kHz variable (HND/HD spec.) 0.75 to 6 kHz variable (ND spec.) <p>VXT-203A-4 to VXT-590A-4:</p> <ul style="list-style-type: none"> 0.75 to 10 kHz variable (HHD spec.) 0.75 to 6 kHz variable (HND/HD/ND spec.) <p>Single phase 200 V class series</p> <p>VXT-3A-1 to VXT-11A-1:</p> <ul style="list-style-type: none"> 0.75 to 16 kHz variable (HHD spec.) <p>Note: The carrier frequency may automatically lower depending upon the ambient temperature or the output current to protect the inverter. (The automatic lowering function can be disabled.)</p>	
	Output frequency accuracy (Stability)	<ul style="list-style-type: none"> Analog setting: $\pm 0.2\%$ of maximum frequency (at $25 \pm 10^\circ\text{C}$) ($77 \pm 18^\circ\text{F}$) Keypad setting: $\pm 0.01\%$ of maximum frequency (at -10 to $+50^\circ\text{C}$) ($14 \pm 22^\circ\text{F}$) 		
	Frequency setting resolution	<ul style="list-style-type: none"> Analog setting: 0.05% of maximum frequency Keypad setting: 0.01 Hz (99.99 Hz or less), 0.1 Hz (100.0 to 500 Hz) Link setting: 0.005% of maximum frequency or 0.01 Hz (fixed) 		
	Speed control range	<ul style="list-style-type: none"> 1: 1500 (Minimum speed : Nominal speed, 4P, 1 to 1500 r/min) 1: 100 (Minimum speed : Nominal speed, 4P, 15 to 1500 r/min) 1: 10 (Minimum speed : Nominal speed, 6P, 180 to 1800 r/min) 	IMPG-VC IMPG-VF PM-SVC	
	Speed control accuracy	<ul style="list-style-type: none"> Analog setting: $\pm 0.2\%$ of maximum frequency or below (at $25 \pm 10^\circ\text{C}$) ($77 \pm 18^\circ\text{F}$) Digital setting: $\pm 0.01\%$ of maximum frequency or below (at -10 to $+50^\circ\text{C}$) (14 to 122°F) 	IMPG-VC	
<ul style="list-style-type: none"> Analog setting: $\pm 0.5\%$ of base frequency or below (at $25 \pm 10^\circ\text{C}$) ($77 \pm 18^\circ\text{F}$) Digital setting: $\pm 0.5\%$ of base frequency or below (-10 to $+50^\circ\text{C}$) (14 to 122°F) 		PM-SVC		
Control method	<ul style="list-style-type: none"> V/f control Vector control without speed sensor (Dynamic torque vector) V/f control, with slip compensation V/f control, with slip sensor (PG option) V/f Control with speed sensor (+Auto Torque Boost)(PG option) Vector control with speed sensor (PG option) Vector control without magnetic pole position sensor 	VF IM-SVC VF with SC IMPG-VF IMPG-ATB IMPG-VC PM-SVC		

Item	Explanation	Remarks
Control method	<ul style="list-style-type: none"> V/f control Vector control without speed sensor (Dynamic torque vector) V/f control, with slip compensation V/f control, with slip sensor (PG option) V/f Control with speed sensor (+Auto Torque Boost)(PG option) Vector control with speed sensor (PG option) Vector control without magnetic pole position sensor 	VF IM-SVC VF with SC IMPG-VF IMPG-ATB IMPG-VC PM-SVC
Voltage/frequency characteristics	<ul style="list-style-type: none"> Possible to set 80 to 240 V / 160 to 500 V at base frequency and at maximum output frequency. Non-linear V/f setting (3 points): Free voltage (0 to 240 V / 500 V) and frequency (0 to 500 Hz) can be set. 	
Torque boost	<ul style="list-style-type: none"> Auto torque boost (For constant torque load) Manual torque boost: Torque boost value can be set between 0.0 and 20.0% Select application load with the function code. (Variable torque load or constant torque load) 	
Starting torque	Three phase 400 V class series <ul style="list-style-type: none"> 200% or above, reference frequency 0.5 Hz (HHD-mode inverters of VXT-72A-4 or below) 150% or above, reference frequency 0.5 Hz (HHD-mode inverters of VXT-85A-4 or above) 120% or above, reference frequency 0.5 Hz (HND/ND mode) 150% or above, reference frequency 0.5 Hz (HD mode) Three phase 200 V class series <ul style="list-style-type: none"> 200% or above, reference frequency 0.5 Hz (HHD-mode inverters of VXT-69A-2 or below) 120% or above, reference frequency 0.5 Hz (HND-mode inverters of VXT-69A-2 or below) Single phase 200 V class series <ul style="list-style-type: none"> 200% or above, reference frequency 0.5 Hz (HHD-mode inverters of VXT-11A-1 or below) Base frequency 50 Hz, with slip compensation and auto torque boost active	
Start/stop operation	Keypad: Start and stop with  and  keys (Standard keypad) Start and stop with  /  and  keys (Optional multi-function keypad)	
	External signals (digital inputs): Forward (Reverse) rotation, stop command (capable of 3-wire operation), coast-to-stop command, external alarm, alarm reset, etc.	
	Link operation: Operation through RS-485 (built-in as standard), CANopen (built-in as standard) or field bus (option) communications link	
	Switching run command: Remote/local switching, link switching	
Frequency setting	Keypad: Using  and  keys	
	External potentiometer: Using external frequency command potentiometer. (External resistor of 1 to 5 kΩ 1/2 W)	
	Analog input: 0 to ±10 VDC (±5 VDC)/ 0 to ±100% (terminal [12]), 0 to +10 VDC (+5 VDC)/ 0 to +100% (terminal [12]) 4 to 20 mADC/ 0 to +100% (terminal [C1] (C1 function)) 4 to 20 mADC/ 0 to ±100% (terminal [C1] (C1 function)) 0 to 20 mADC/ 0 to +100% (terminal [C1] (C1 function)) 0 to 20 mADC/ 0 to ±100% (terminal [C1] (C1 function)) 0 to +10 VDC (+5 VDC)/ 0 to +100% (terminal [C1] (V2 function)), 0 to +10 VDC (+5 VDC)/ 0 to ±100% (terminal [C1] (V2 function))	
	UP/DOWN operation: Frequency can be increased or decreased while the digital input signal is ON.	
	Multistep frequency: Selectable from 16 different frequencies (step 0 to 15)	
	Pattern operation: The inverter runs automatically according to the previously specified run time, rotation direction, acceleration/deceleration time and reference frequency. Up to 7 stages can be specified.	

Item	Explanation	Remarks
	Link operation: Operation through RS-485 (built-in as standard), CANopen (built-in as standard) or field bus (option) communications link	
	Frequency setting: Two types of frequency settings can be switched with an external signal (digital input). Remote/local switching, link switching	
Frequency setting	Auxiliary frequency setting: Inputs at terminal [12], [C1] (C1 function) or [C1] (V2 function) can be added to the main setting as auxiliary frequency settings.	
	Operation at a specified ratio: The ratio can be set by analog input signal. 0 to 10 VDC/0 (4) to 20 mA/0 to 200% (variable)	
	Inverse operation: Switchable from "0 to +10 VDC/0 to 100%" to "+10 to 0 VDC/0 to 100%" for the external command (terminals [12] and [C1] (V2 function)) Switchable from "0 to -10 VDC/0 to -100%" to "-10 to 0 VDC/0 to -100%" for the external command (terminal [12]) Switchable from "4 to +20 mA DC/0 to 100%" to "20 to 4 mA DC/0 to 100%" for the external command (terminal [C1] (C1 function)) Switchable from "0 to +20 mA DC/0 to 100%" to "20 to 0 mA DC/0 to 100%" for the external command (terminal [C1] (C1 function))	
	Pulse train input (standard): Pulse input = Terminal [X5], Rotational direction = general terminal Complementary output: Max. 100 kHz, Open collector output: Max. 30 kHz	
	Pulse train input (option): A PG option card is required. CW/CCW pulse, pulse + rotational direction Complementary output: Max. 100 kHz, Open collector output: Max. 30 kHz	
Control Acceleration/ deceleration time	Setting range: Between 0.00 and 6000 s	
	Switching: The four types of acceleration/deceleration time can be set or selected individually (switchable during operation).	
	Acceleration/deceleration pattern: Linear acceleration/deceleration, S-curve acceleration/deceleration (weak, arbitrary (with function code)), curvilinear acceleration/deceleration	
	Deceleration mode (coast-to-stop): Shutoff of the run command lets the motor coast to a stop.	
	Acceleration/deceleration time exclusive to jogging (0.00 to 6000 s)	
	Forcible stop deceleration time: Deceleration stop by the forcible stop STOP . During forced stop operation, S-curve acceleration/deceleration is disabled.	
Frequency limiter (Upper limit and lower limit frequencies)	<ul style="list-style-type: none"> Specifies the upper and lower limits in Hz. "Continue to run" or "Decelerate to a stop" selectable when the reference frequency drops below the lower limit. 	
Frequency/PID command bias	<ul style="list-style-type: none"> Bias of reference frequency and PID command can be independently set (setting range: 0 to $\pm 100\%$). 	
Analog input	<ul style="list-style-type: none"> Gain: Setting range from 0 to 200% Offset: Setting range from -5.0 to +5.0% Filter: Setting range from 0.00 s to 5.00 s Polarity selection (\pm/+) 	
Jump frequency	<ul style="list-style-type: none"> Three operation points and their common jump width (0 to 30.0 Hz) can be set. 	
Timed operation	The inverter drives the motor for the run time specified from the keypad and stops its output. (Single-cycle operation)	
Jogging operation	<ul style="list-style-type: none"> Operation with  key (standard keypad),  or  key (multi-function keypad), or digital input signal FWD or REV (Exclusive acceleration/deceleration time setting, exclusive frequency setting) 	

Item	Explanation	Remarks	
Auto-restart after momentary power failure	<ul style="list-style-type: none"> • Trip immediately: Trip immediately at the time of power failure. • Trip after a recovery from power failure: Coast to a stop at the time of power failure and trip when the power is recovered. • Trip after decelerate-to-stop: Deceleration stop at power failure, and trip after stoppage • Continue to run: Operation is continued using the load inertia energy. • Start at the frequency selected before momentary power failure: Coast-to-stop at power failure and start after power recovery at the frequency selected before momentary stop. • Start at starting frequency: Coast-to-stop at power failure and start at the starting frequency after power recovery. • Start at the frequency searched at the time of power recovery: Coast-to-stop at power failure, search for the idling motor speed, and restart the motor. 		
Hardware current limiter	Limits the current by hardware to prevent an overcurrent trip from being caused by fast load variation or momentary power failure, which cannot be covered by the software current limiter. This limiter can be canceled.		
Operation by commercial power supply	With commercial power selection commands (SW50 , SW60), the inverter outputs 50/60 Hz.		
Slip compensation	<ul style="list-style-type: none"> • Compensates for decrease in speed according to the load • Possible to set constants for the response of slip compensation. 		
Droop control	<ul style="list-style-type: none"> • Decreases the speed according to the load torque. 		
Torque limiter	Control output torque so that output torque is preset limiting value or less. <ul style="list-style-type: none"> • Switchable between 1st and 2nd torque limit values 		
Torque current limiter	<ul style="list-style-type: none"> • Torque limit and Torque current limit are selectable. • Torque limit by analog input. 	IMPG-VC PM-SVC	
Software current limiter	Automatically reduces the frequency so that the output current becomes lower than the preset operation level. This limiter can be canceled.		
Overload stop	If the detected torque or current exceeds the preset value, the inverter decelerates the motor to a stop or causes the motor to coast to a stop.		
Control	PID control	<ul style="list-style-type: none"> • PID processor for process control/dancer control • Normal operation/inverse operation • PID command: Keypad, analog input (from terminals [12], [C1] (C1 function) and [C1] (V2 function)), multistep frequency (3 steps), RS-485 communication • PID feedback value: Analog input (from terminals [12], [C1] (C1 function) and [C1] (V2 function)) • Alarm output (absolute value alarm, deviation alarm) • Low liquid level stop function (pressurized operation possible before low liquid level stop) • Anti-reset wind-up function • PID output limiter • Integration reset/hold 	
	Auto search for idling motor speed	The inverter automatically searches for the idling motor speed and starts to drive it without stopping it. Motor parameters require tuning. (Offline tuning)	
	Automatic deceleration	<ul style="list-style-type: none"> • If the DC link bus voltage or calculated torque exceeds the automatic deceleration level during deceleration, the inverter automatically prolongs the deceleration time to avoid overvoltage trip. (It is possible to select forcible deceleration actuated when the deceleration time becomes three times longer.) • If the calculated torque exceeds automatic deceleration level during constant speed operation, the inverter avoids overvoltage trip by increasing the frequency. 	
	Deceleration characteristic (improved braking capacity)	The motor loss is increased during deceleration to reduce the regenerative energy in the inverter to avoid overvoltage trip.	
	Auto energy saving operation	Controls the output voltage to minimize the total sum of the motor loss and inverter loss.	
	Overload prevention control	If the surrounding temperature or IGBT junction temperature increases due to overload, the inverter lowers the output frequency to avoid overload.	

Item	Explanation	Remarks
Battery/UPS operation	Cancels the undervoltage protection so that the inverter under an undervoltage condition runs the motor with battery/UPS power.	
Offline tuning	Tunes the motor while the motor is stopped or running, for setting up motor parameters.	
Online tuning	Controls the motor speed variation caused by the motor temperature rise during running.	
Cooling fan ON/OFF control	<ul style="list-style-type: none"> • Detects inverter internal temperature and stops cooling fan when the temperature is low. • Possible to output a fan control signal to an external device. 	
1st to 2nd motor settings	<ul style="list-style-type: none"> • Switchable between two motors <p>It is possible to set the base frequency, rated current, torque boost, and electronic thermal slip compensation as the data for 1st and 2nd motors.</p>	

Item	Explanation	Remarks	
Universal DI	Transfers the status of an external digital signal connected with the general-purpose digital input terminal to the host controller.		
Universal DO	Outputs a digital command signal sent from the host controller to the general-purpose digital output terminal.		
Universal AO	Outputs an analog command signal sent from the host controller to the analog output terminal.		
Speed control	<ul style="list-style-type: none"> Notch filter for vibration control Selectable among the four set of the auto speed regulator (ASR) parameters. (a PG option card is required.) 	IMPG-VC PM-SVC	
Line speed control	In a machine such as winder/unwinder, regulates the motor speed to keep the peripheral speed of the spool constant. (a PG option card is required.)	IMPG-VF	
Positioning control with pulse counter	<p>The positioning control starts from the preset start point and counts the feedback pulses by means of PG card installed in the inverter.</p> <p>The motor can be automatically started decelerating to the creep speed at which the target position can be detected, so that the motor can stop near the position (a PG option card is required).</p>	Excluded IMPG-VC PM-SVC	
Master-follower operation	Enables synchronous operation of two motors equipped with a pulse generator (PG). (a PG option card is required.)		
Pre-excitation	Excitation is carried out to create the motor flux before starting the motor. (a PG option card is required.)	IMPG-VC	
Zero speed control	The motor speed is held to zero by forcibly zeroing the speed command. (a PG option card is required.)	IMPG-VC	
Servo lock	Stops the motor and holds the motor in the stopped position.(a PG option card is required.)	IMPG-VC	
Control	DC braking	Applies DC current to the motor at the operation start time or at the time of inverter stop to generate braking torque.	
	Mechanical brake control	<ul style="list-style-type: none"> Possible to output mechanical brake control signals with the brake ON/OFF timing adjusted by the output current, torque command, output frequency and timer. Mechanical brake application check input. 	
	Torque control	<ul style="list-style-type: none"> Analog torque/torque current command input Speed limit function is provided to prevent the motor from becoming out of control. Torque bias (analog setting, digital setting) (The PG option card is required.)	IMPG-VC
	Rotation direction control	Select either of reverse or forward rotation prevention.	
	Customizable logic interface	<p>Possible to select or connect digital logic circuits or analog operation circuits with digital/analog I/O signals, configure a simple relay sequence, and operate it freely.</p> <ul style="list-style-type: none"> Logic circuits: (Digital) AND, OR, XOR, flip-flop, detection of rising and falling edges, various counters. (Analog) Addition, subtraction, multiplication, division, limiters, absolute values, sign inversion addition, comparison, maximum value selection, minimum value selection, average values, scale conversion. Multifunction time: On-delay timer, off-delay timer, pulse train output, etc. Setting range: 0.0 to 9990 s Input/output signals: Terminal input/output, inverter control functions Others: Available in 200 steps configured with 2 inputs and 1 output per step. 	
	Functions for wiredrawing machines, hoists, and spinning frames	Customizable logic function enables dedicated functions for each application.	

Item	Explanation	Remarks
Indicators	Detachable, 7-segment, 4-digit LED, 7 push-buttons (PRG/RESET, FUNC/DATA, UP, DOWN, RUN, STOP, and SHIFT), and 6 LED indicators (KEYPAD CONTROL, Hz, A, kW, X10, and RUN)	
Running/stopping	Speed monitor (reference frequency, output frequency, motor speed, load shaft speed, line speed, and speed indication with percent), output current (A), output voltage (V), calculated torque (%), input power (kW), PID command value, PID feedback amount, PID output, timer values for timed operation (s), load factor (%), and motor output (kW), Torque current [%], Magnetic flux command [%], Analog input monitor, input watt-hour, constant feeding rate time (min.), and remaining time for timed operation (s) can be displayed.	
Maintenance monitor	DC link bus voltage, maximum effective current, input watt-hour, input watt-hour data, temperature (inverter internal temperature, maximum inverter internal temperature, heat sink temperature, maximum heat sink temperature), capacitance of the DC link bus capacitor, service life of DC link but capacitor (elapsed time/remaining time), cumulative run times (inverter power-ON time, electrolytic capacitors on printed circuit boards, cooling fans, individual motors), light-alarm contents (last four alarms), RS-485 error contents and number of error times, CANopen error contents, option error contents and number of error times, ROM version (inverter, keypad, and option)	
I/O check	Displays the I/O signal states of control circuit terminals using the segment ON/OFF of the 7-segment LED monitor or hexadecimal format. (digital and analog signals)	
Trip	Displays the cause of a trip by codes.	
Light-alarm	Shows the light-alarm display <i>l-a</i> .	
During running or at the time of a trip	<ul style="list-style-type: none"> • Trip history: Saves and displays the cause of the last four trips (with a code). • Saves and displays the detailed running status data of the last four trips. 	

*Note: The meaning of the described abbreviations are shown as follows.

VF V/f Control

IM-SVC(DTV) Speed Sensorless Vector control (Dynamic Torque Vector Control)

VF with SC V/f Control with Slip Compensation

IMPG-VF V/f Control with Speed Sensor (a PG option card is required.)

IMPG-ATB V/f Control with speed sensor (+ Auto Torque Boost)(A PG option card is required.)

IMPG-VC Vector Control with Speed Sensor (a PG option card is required.)

PM-SVC Magnetic Pole Position Sensorless Vector Control

When the protective function is activated so that the LED monitor shows alarm codes, refer to Chapter 6 "TROUBLESHOOTING."

For the usage environment and storage environment, refer to Chapter 1 "1.3 Precautions for Using Inverters."



Chapter 9 EXTERNAL DIMENSIONS

This chapter describes the external dimensions of the inverter.

Contents

- 9.1 Standard Model (VXT-69A-2, VXT-44A-4, VXT-11A-1 or below).....9-1
- 9.2 Standard / EMC Filter Built-in Type (VXT-88A-2 / 2E, VXT-59A-4 / 4E or above).....9-6
- 9.3 Keypad 9-14

9.1 Standard Model

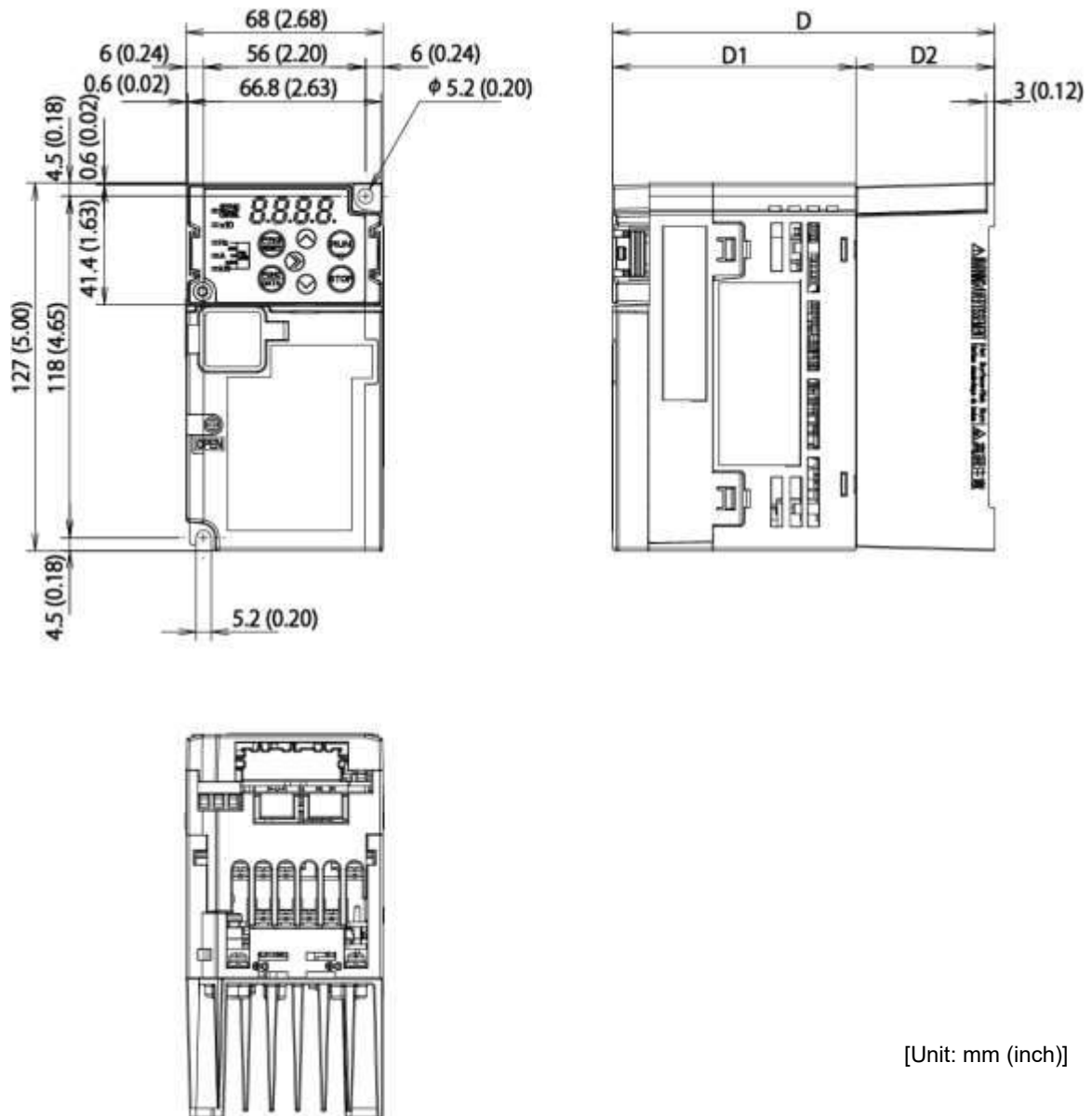

[Unit: mm (inch)]

Figure 9.1-1

Power supply voltage	Inverter type	Dimension [mm (inch)]		
		D	D1	D2
Three-phase 200V	VXT-4A-2	100 (3.94)	77 (3.03)	23 (0.91)
	VXT-6A-2	132 (5.20)	84 (3.31)	48 (1.89)
Single-phase 200V	VXT-3A-1	107 (4.21)	84 (3.31)	23 (0.91)
	VXT-5A-1	152 (5.98)	104 (4.09)	48 (1.89)

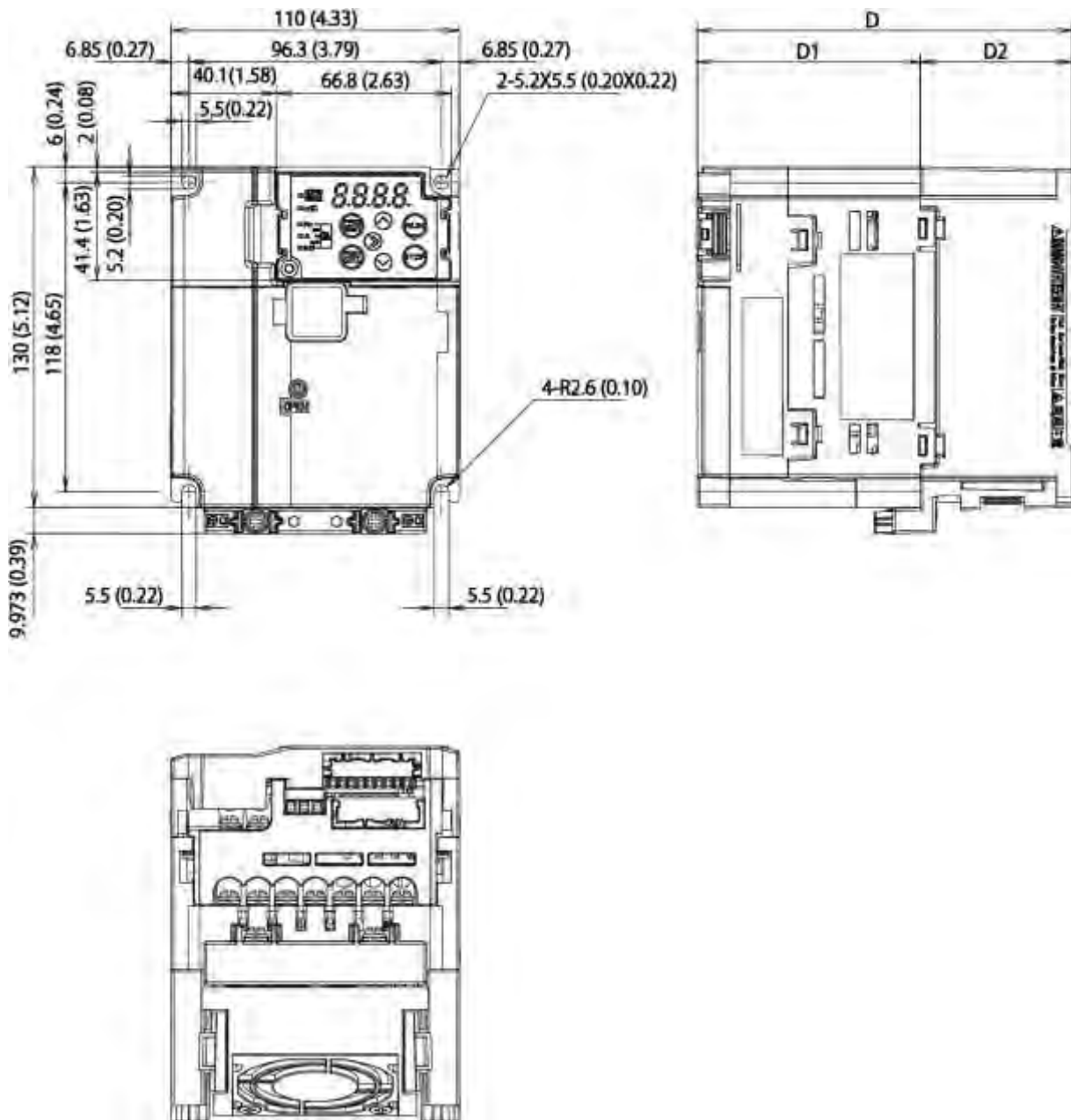

Figure 9.1-2

Power supply voltage	Inverter type	Dimension [mm (inch)]		
		D	D1	D2
Three-phase 200V	VXT-10A-2	143 (5.63)	85 (3.35)	58 (2.28)
	VXT-12A-2	143 (5.63)	85 (3.35)	58 (2.28)
Three-phase 400V	VXT-2A-4	119 (4.69)	85 (3.35)	34 (1.34)
	VXT-4A-4	143 (5.63)	85 (3.35)	58 (2.28)
	VXT-6A-4	143 (5.63)	85 (3.35)	58 (2.28)
	VXT-7A-4	143 (5.63)	85 (3.35)	58 (2.28)
Single-phase 200V	VXT-8A-1	153 (6.02)	95 (3.74)	58 (2.28)

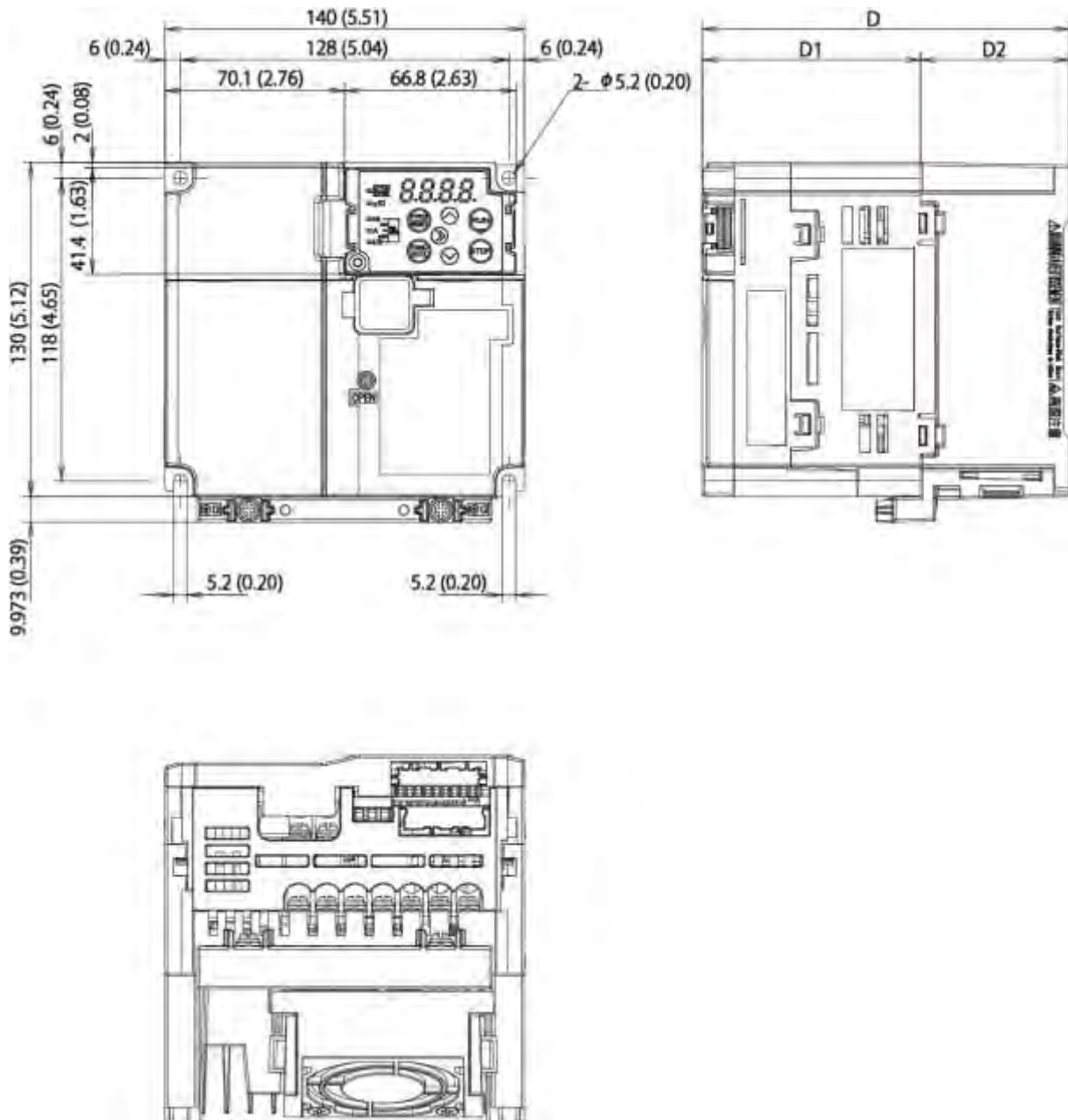

Figure 9.1-3

Power supply voltage	Inverter type	Dimension [mm (inch)]		
		D	D1	D2
Three-phase 200V	VXT-20A-2	143 (5.63)	85 (3.35)	58 (2.28)
Three-phase 400V	VXT-12A-4	143 (5.63)	85 (3.35)	58 (2.28)
Single-phase 200V	VXT-11A-1	143 (5.63)	85 (3.35)	58 (2.28)

* The figure given in the lower right-hand corner of each set of drawings shows the dimension of panel cutting required for external cooling. To employ external cooling for inverters VXT-30A-2 to VXT-115A-2/E and VXT-22A-4 to VXT-72A-4/E, the optional mounting adapter for external cooling is required.

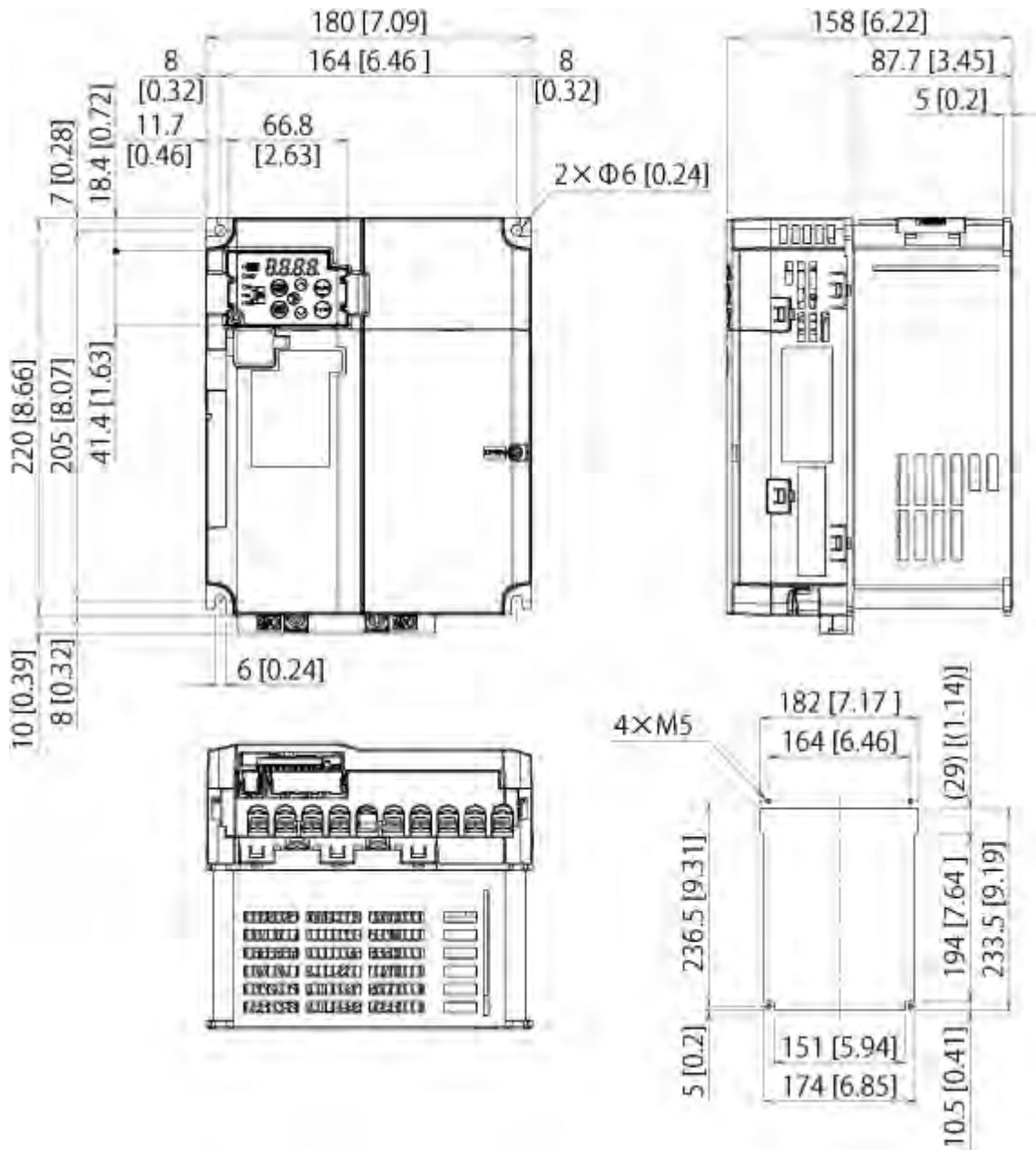

Figure 9.1-4

(Unit: mm [inch])

Power supply voltage	Inverter type
Three-phase 200V	VXT-30A-2
	VXT-40A-2
Three-phase 400V	VXT-22A-4
	VXT-29A-4

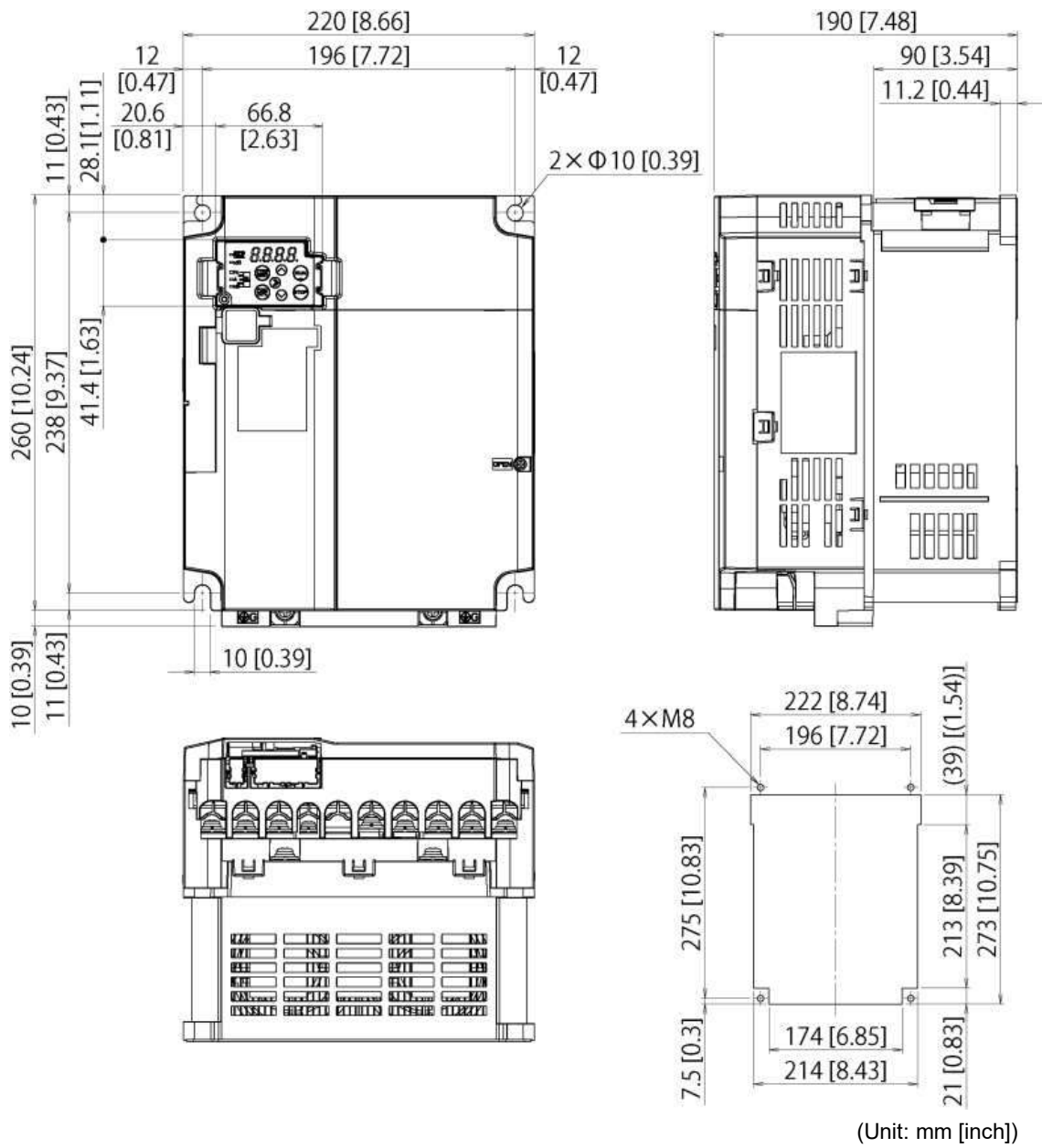
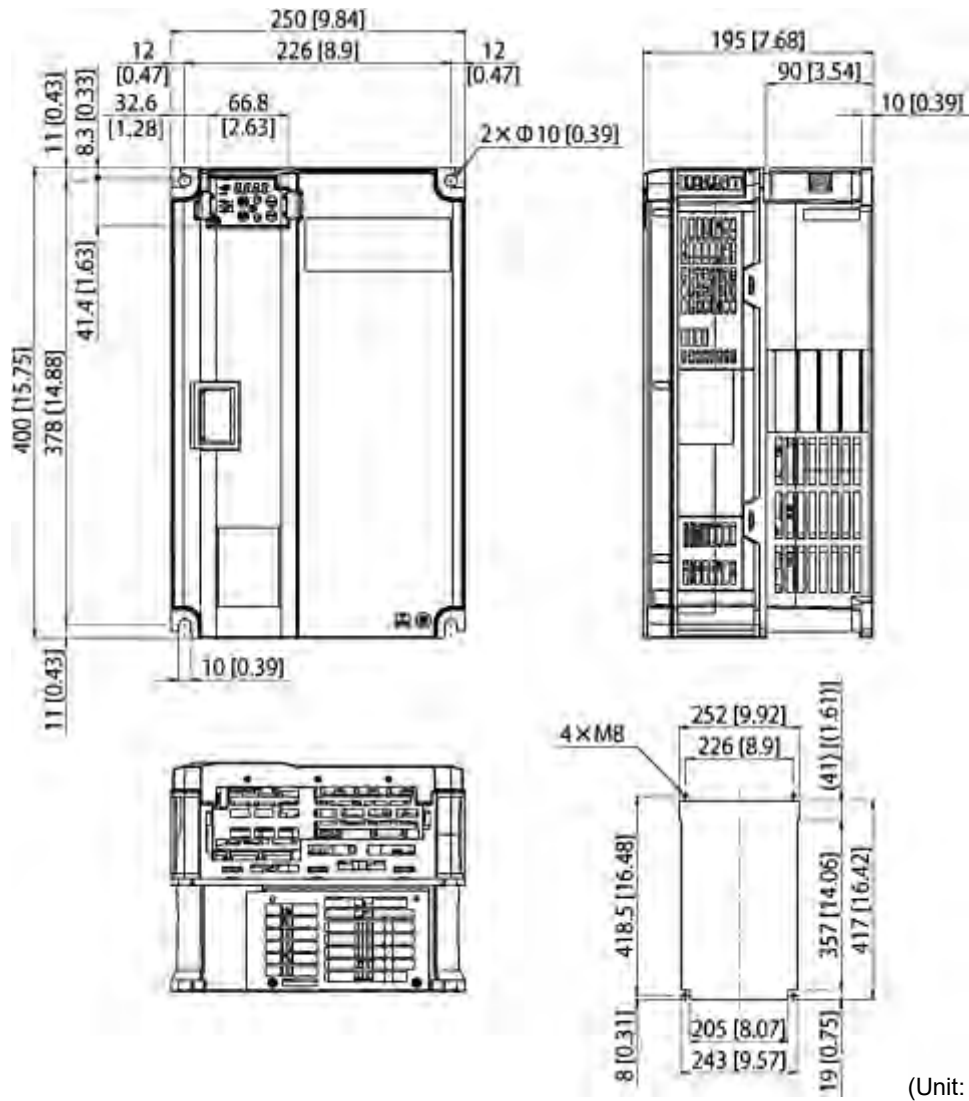

Figure 9.1-5

Power supply voltage	Inverter type
Three-phase 200V	VXT-56A-2
	VXT-69A-2
Three-phase 400V	VXT-37A-4
	VXT-44A-4

9.2 Standard / EMC Filter Built-in Type



(Unit: mm [inch])

Figure 9.2-1

Power supply voltage	Model	Inverter type
Three-phase 200V	Standard model	VXT-88A-2
		VXT-115A-2
	EMC-filter built in type	VXT-88A-2E
		VXT-115A-2E
Three-phase 400V	Standard model	VXT-59A-4
		VXT-72A-4
	EMC-filter built in type	VXT-59A-4E
		VXT-72A-4E

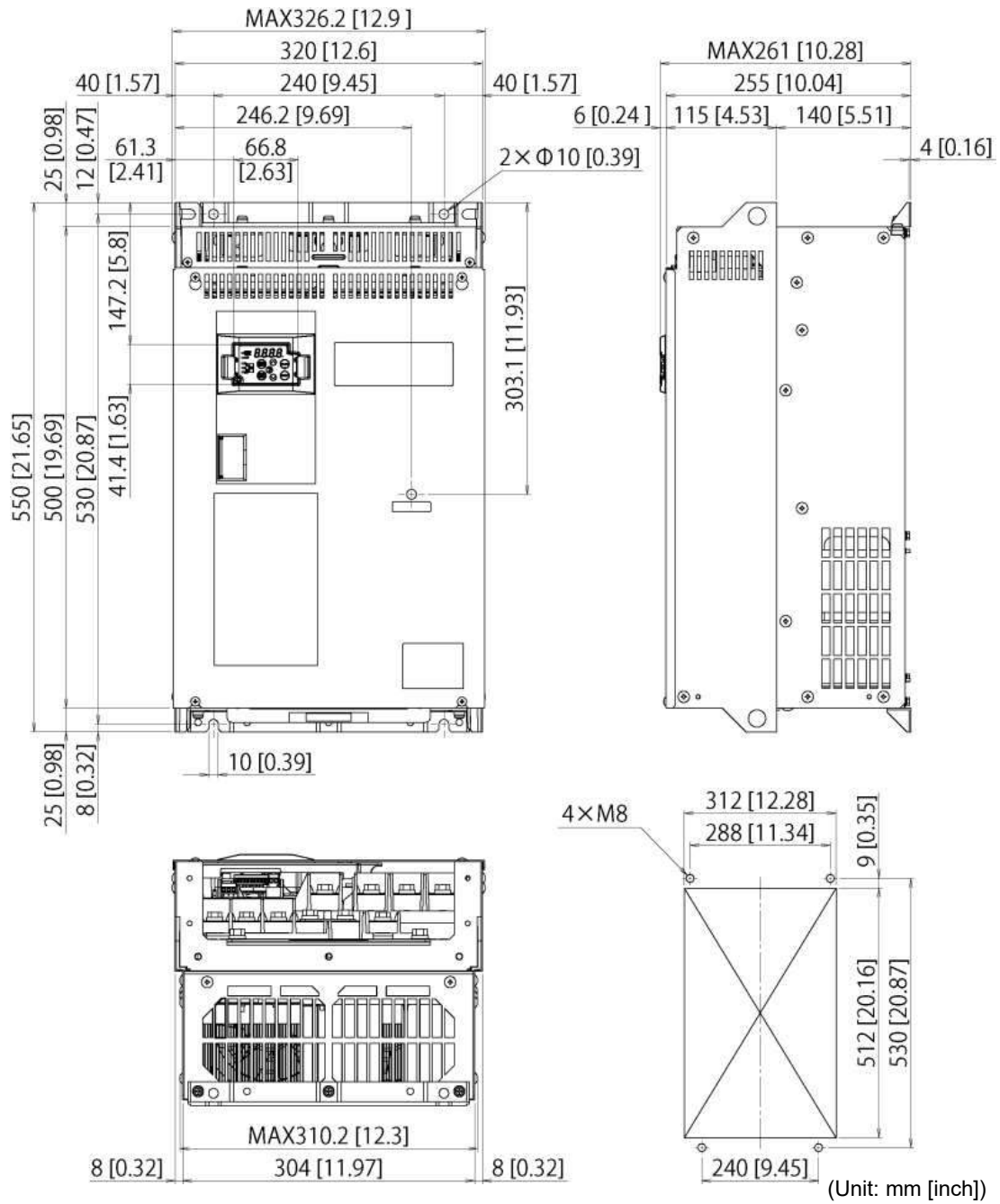

Figure 9.2-2

Power supply voltage	Model	Inverter type
Three-phase 400V	Standard model	VXT-85A-4
		VXT-105A-4
	EMC-filter built in type	VXT-85A-4E
		VXT-105A-4E

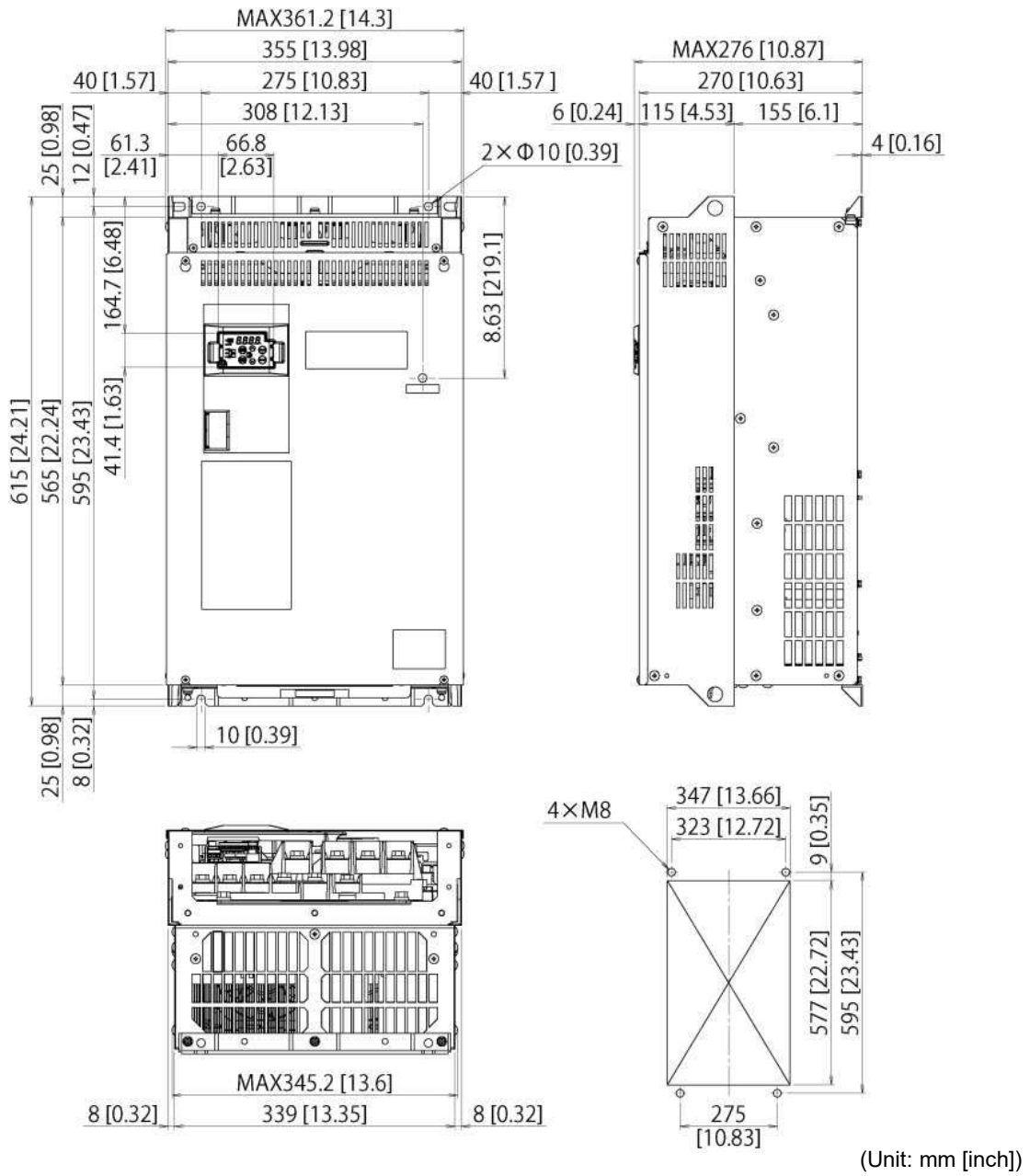

Figure 9.2-3

Power supply voltage	Model	Inverter type
Three-phase 400V	Standard model	VXT-139A-4
	EMC-filter built in type	VXT-139A-4E

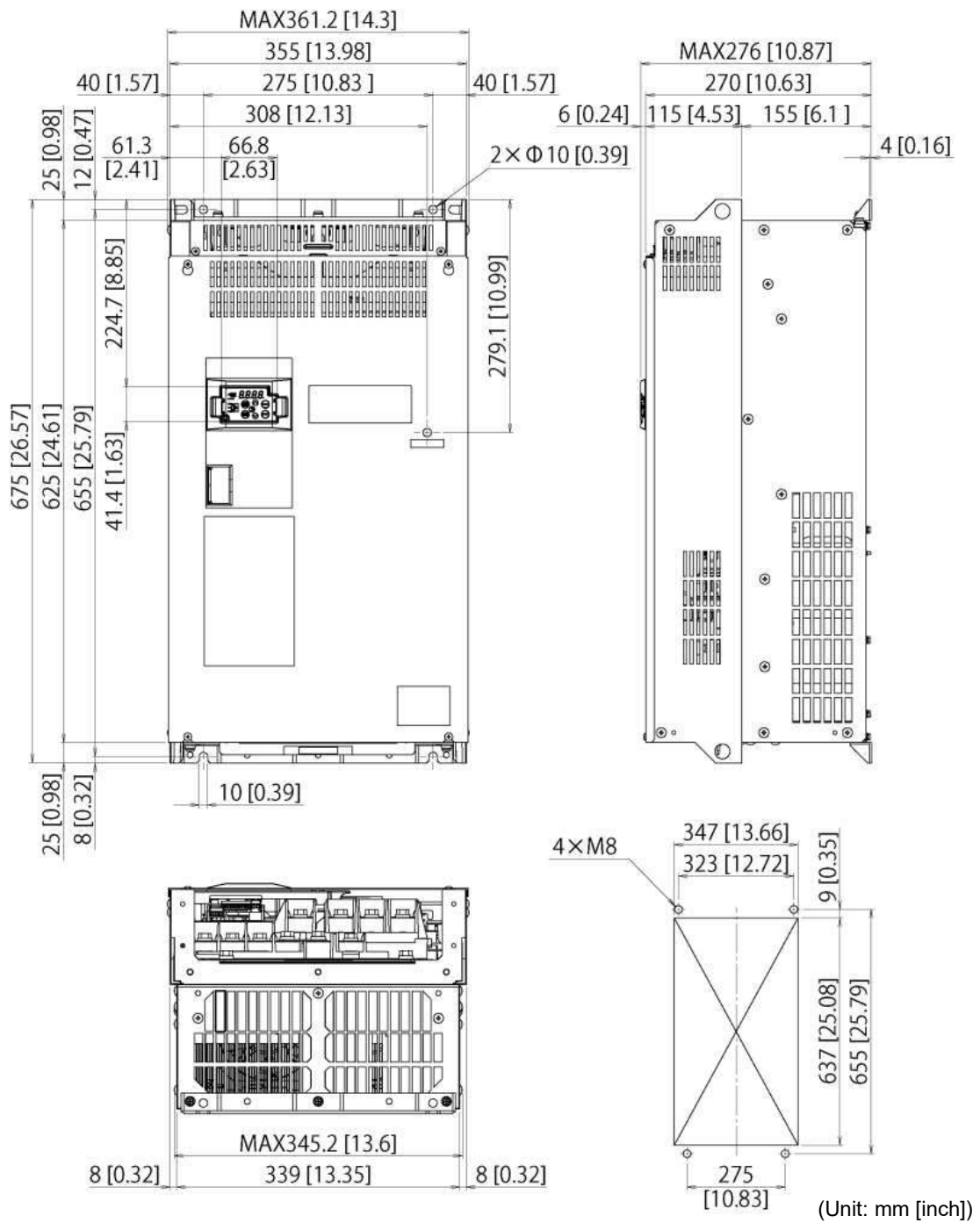
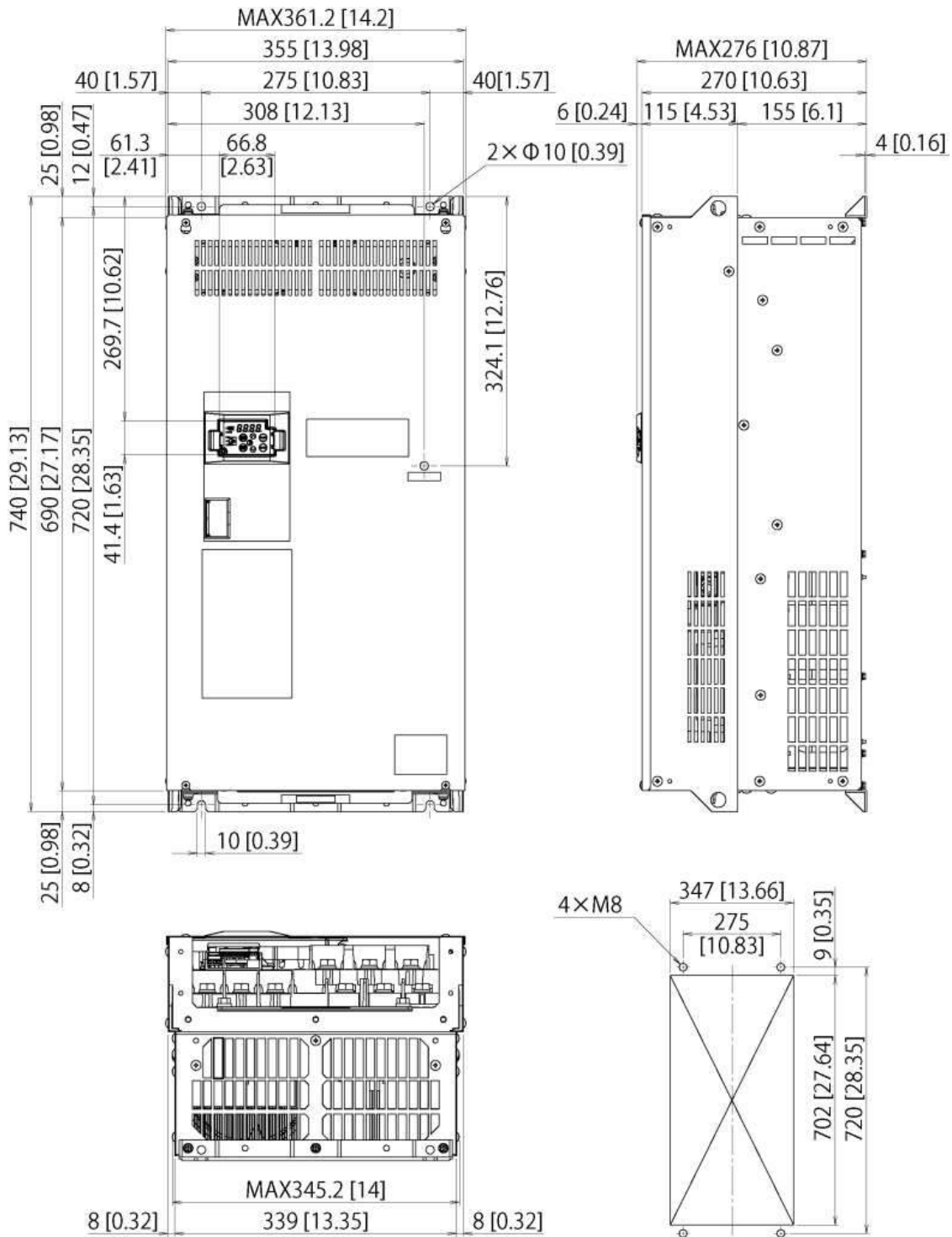

Figure 9.2-4

Power supply voltage	Model	Inverter type
Three-phase 400V	Standard model	VXT-168A-4
	EMC-filter built in type	VXT-168-4E



(Unit: mm [inch])

Figure 9.2-5

Power supply voltage	Model	Inverter type
Three-phase 400V	Standard model	VXT-203A-4
	EMC-filter built in type	VXT-203A-4E

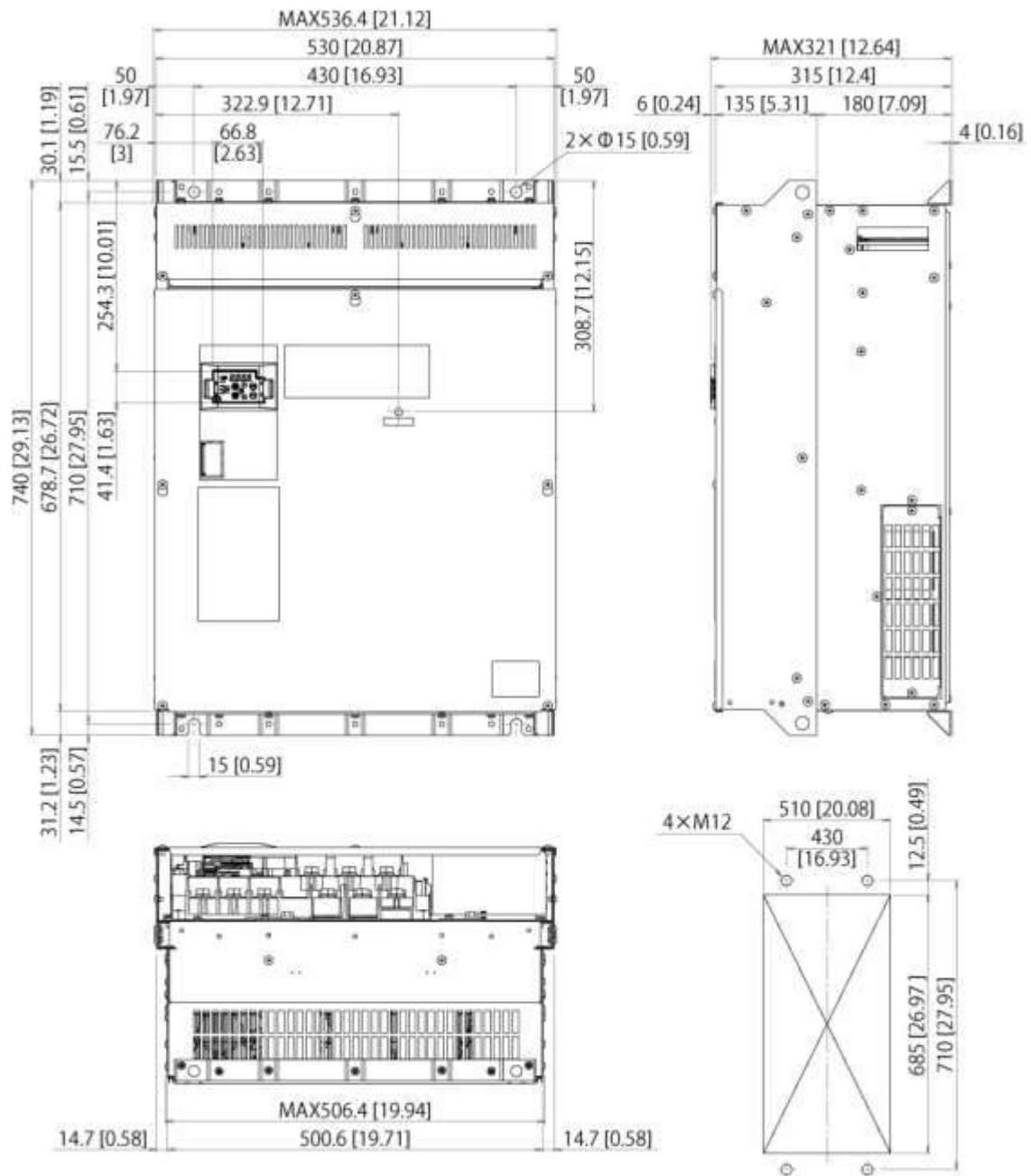

(Unit: mm [inch])

Figure 9.2-6

Power supply voltage	Model	Inverter type
Three-phase 400V	Standard model	VXT-290A-4
		VXT-290A-4
	EMC-filter built in type	VXT-240A-4E
		VXT-290A-4E

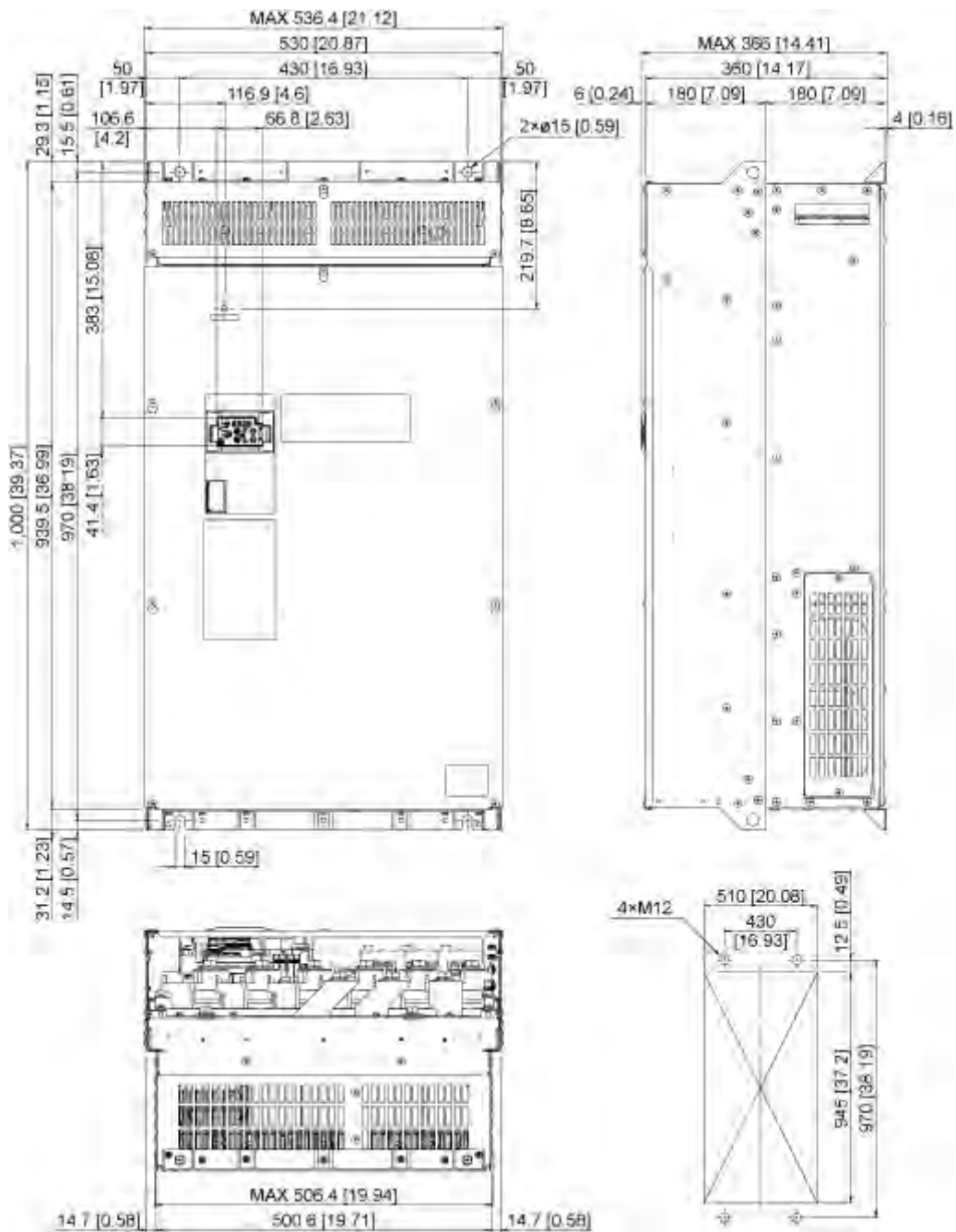
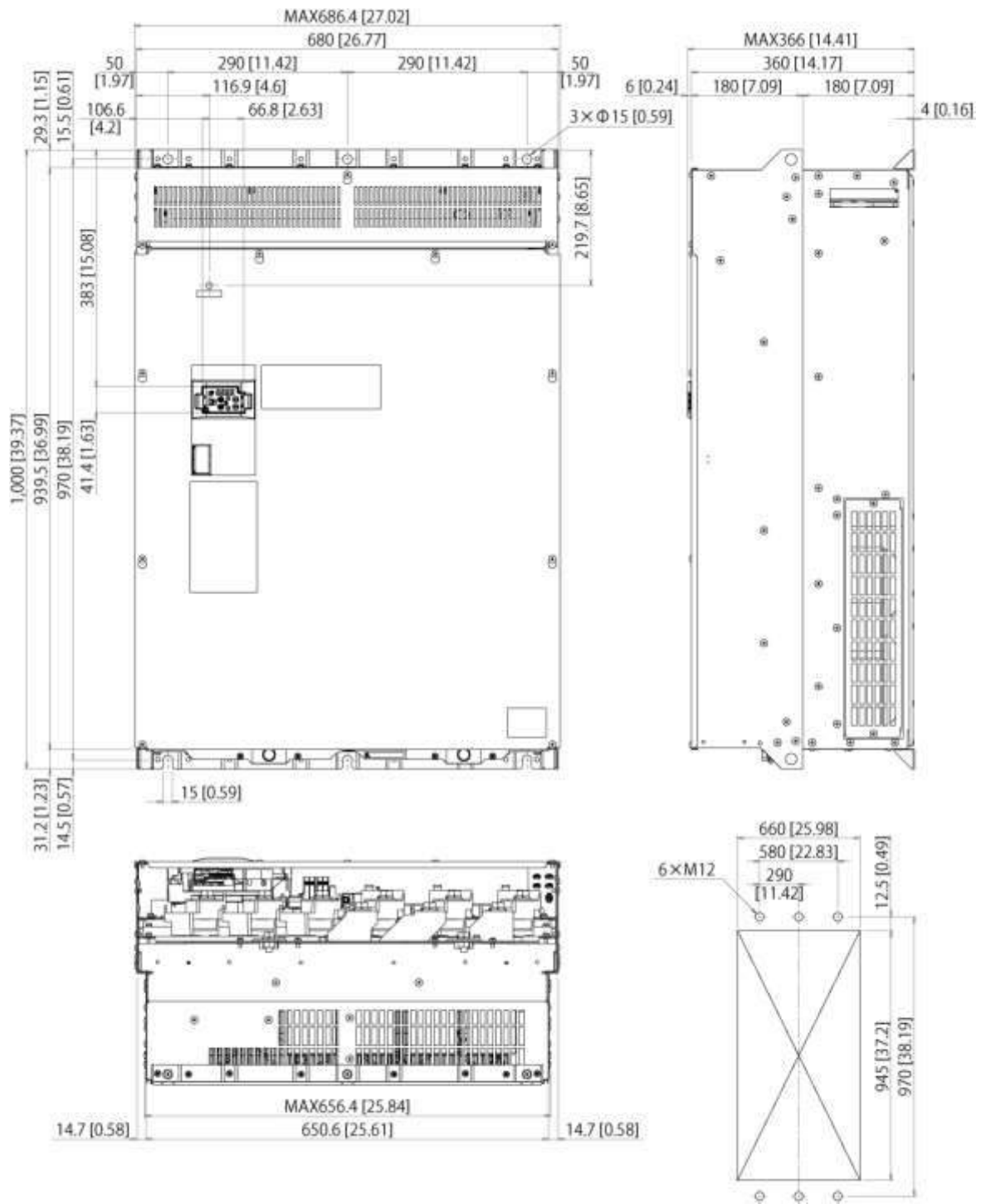

Figure 9.2-7

(Unit: mm [inch])

Power supply voltage	Model	Inverter type
Three-phase 400V	Standard model	VXT-361A-4
		VXT-415A-4
	EMC-filter built in type	VXT-361A-4E
		VXT-415A-4E



(Unit: mm [inch])

Figure 9.2-8

Power supply voltage	Model	Inverter type
Three-phase 400V	Standard model	VXT-520A-4
		VXT-590A-4
	EMC-filter built in type	VXT-520A-4E
		VXT-590A-4E

9.3 Keypad

(Unit: mm [inch])

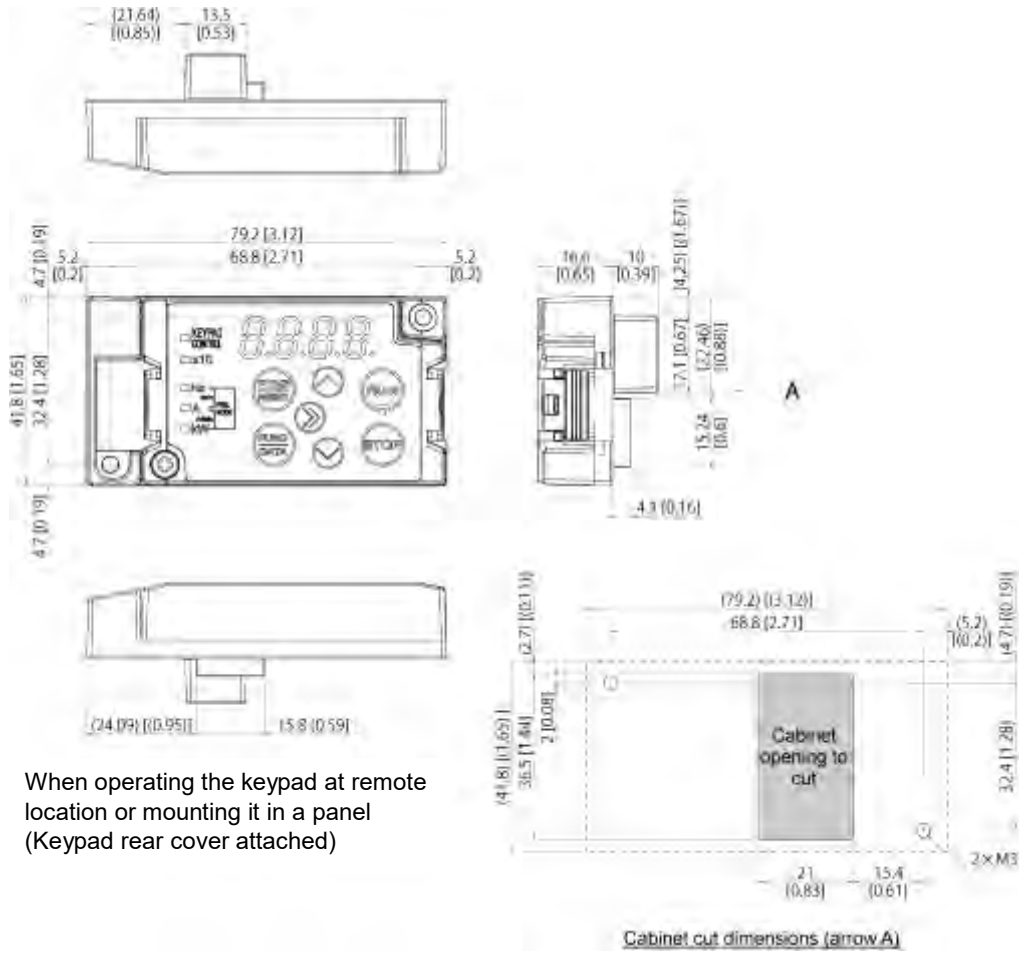

When operating the keypad at remote location or mounting it in a panel (Keypad rear cover attached)

Dimensions of panel cutting (viewed from arrow "A")

High Performance Inverter.

Jaguar VXT

Instruction Manual

1st Edition, Jan 2016

IMO Precision Controls Ltd

The purpose of this instruction manual is to provide accurate information in handling, setting up and operating of the JAGUAR VXT series of inverters. Please feel free to send your comments regarding any errors or omissions you may have found, or any suggestions you may have for generally improving the manual.

In no event, will IMO Precision Controls Ltd. be liable for any direct or indirect damages resulting from the application of the information in this manual.

IMO Precision Controls Ltd.

1000 North Circular Road, Staples Corner, London, NW2 7JP England

Phone: +44 (0)20 8452 6444 Fax: +44 (0)20 8450 2274

URL <http://www.imopc.com>
